

Providing 24/7 Space Science Research

STS

107



WWW.SHUTTLEPRESSKIT.COM



Updated December 16, 2002



Table of Contents

Mission Overview	1
Timeline Overview	9
Mission Profile	17
Crew	19
Payloads	
SPACEHAB Research Double Module and SPACEHAB Commercial Payloads	26
Master Experiment List	32
Biology Experiments	
Biological Research in Canisters (BRIC)	34
Biotechnology Demonstration System (BDS-05)	36
European Space Agency BIOPACK	38
Anatomical Studies of Central Vestibular Adaptation.....	40
Arterial Remodeling and Functional Adaptations	42
Choroidal Regulation Involved in the Cerebral Fluid	44
Magnetic Field Apparatus (MFA/BIOTUBE).....	46
Biomedical Research and Counter Measures Experiments	
Calcium Kinetics During Spaceflight.....	48
Flight Induced Changes in Immune Defenses	50
Incidence of Latent Virus Shedding During Spaceflight	52
Microbial Physiology Flight Experiments.....	54
Protein Turnover During Spaceflight.....	56



Renal Stone Risk During Spaceflight.....	58
Sleep-Wake Actigraphy and Light Exposure During Spaceflight.....	60
Earth & Space Sciences	
Mediterranean Israeli Dust Experiment (MEIDEX).....	62
Shuttle Ionospheric Modification (SIMPLEX)	64
Shuttle Ozone Limb Sounding Experiment-2 (SOLSE-2).....	65
Solar Constant Experiment (SOLCON-3)	67
Physical Sciences	
Combustion Module-2 (CM-2).....	69
Critical Viscosity of Xenon-2 (CVX-2)	71
Laminar Soot Processes-2 (LSP-2)	73
Mechanics of Granular Materials-3 (MGM-3).....	75
Space Acceleration Measurement System Free Flyer (SAMS-FF) and Orbiter Acceleration Research Experiment (OARE)	78
Structures of Flame Balls (SOFBALL)	80
Space Product Development	
ASTROCULTURE TM	82
Commercial Instrumentation Technology (CIBX-2).....	85
Commercial Protein Crystal Growth (CPCG-H)	88
Water Mist Fire Suppression Experiment (MIST).....	90
Zeolite Crystal Growth (ZCG).....	93
Technology Development	
Low Power Transceiver (LPT).....	95
Ram Burn Observations (RAMBO)	96
Vapor Compression Distillation Flight Experiment	97



Advanced Respiratory Monitoring System (ARMS) Support System	100
European Space Agency (ESA) Payloads Overview.....	102
Fast Reaction Experiments Enabling Science, Technology, Applications and Research (FREESTAR)	104
National Space Development Agency of Japan (NASDA) STS-107 Space Experiment Project.....	115
Space Technology and Research Students (STARS) Student Experiments.....	120
Detailed Test Objectives (DTOs) and Detailed Supplementary Objectives (DSOs)	124
Shuttle Reference Data	125
Acronyms and Abbreviations	143
Media Assistance	148
Media Contacts	150



Mission Overview

STS-107: Providing 24/7 Space Science Research

Space shuttle mission STS-107, the 28th flight of the space shuttle Columbia and the 113th shuttle mission to date, will give more than 70 international scientists access to both the microgravity environment of space and a set of seven human researchers for 16 uninterrupted days.



The STS-107 crew. Seated in front are astronauts Rick Husband, commander, and Willie McCool, pilot. Standing are (from left) mission specialists Dave Brown, Laurel Clark, Kalpana Chawla, Mike Anderson (payload commander) and payload specialist Ilan Ramon, representing the Israeli Space Agency.

Columbia's 16-day mission is dedicated to a mixed complement of competitively selected and commercially sponsored research in the space, life and physical sciences. An international crew of seven, including the first Israeli astronaut, will work 24 hours a day in two alternating shifts to carry out experiments in the areas of astronaut health and safety; advanced technology development; and Earth and space sciences.



***The Spacehab Research Double Module is prepared for flight
at Kennedy Space Center***



When Columbia is launched from Kennedy Space Center's Launch Pad 39A it will carry a SPACEHAB Research Double Module (RDM) in its payload bay. The RDM is a pressurized environment that is accessible to the crew while in orbit via a tunnel from the shuttle's middeck. Together, the RDM and the middeck will accommodate the majority of the mission's payloads/experiments. STS-107 marks the first flight of the RDM, though SPACEHAB Modules and Cargo Carriers have flown on 17 previous space shuttle missions.

Astronaut Rick Husband (Colonel, USAF) will command STS-107 and will be joined on Columbia's flight deck by pilot William "Willie" McCool (Commander, USN). Columbia will be crewed by Mission Specialist 2 (Flight Engineer) Kalpana Chawla (Ph.D.), Mission Specialist 3 (Payload Commander) Michael Anderson (Lieutenant Colonel, USAF), Mission Specialist 1 David Brown (Captain, USN), Mission Specialist 4 Laurel Clark (Commander, USN) and Payload Specialist 1 Ilan Ramon (Colonel, Israeli Air Force), the first Israeli astronaut.

STS-107 marks Husband's second flight into space – he served as pilot during STS-96, a 10-day mission that saw the first shuttle docking with the International Space Station. Husband served as Chief of Safety for the Astronaut Office until his selection to command the STS-107 crew. Anderson and Chawla will also be making their second spaceflights. Anderson first flew on STS-89 in January 1998 (the eighth Shuttle-Mir docking mission) while Chawla flew on STS-87 in November 1997 (the fourth U.S. Microgravity Payload flight). McCool, Brown, Clark and Ramon will be making their first flights into space.



National Aeronautics and
Space Administration

STS-107 Shuttle Press Kit



STS-107 Payload Specialist Ilan Ramon, from Israel, trains on equipment at SPACEHAB, Cape Canaveral, Fla.



The seven crewmembers will work in two shifts throughout their 16 days in space. The Red Shift will include Husband, Chawla, Clark and Ramon, while the Blue Shift will include McCool, Brown and Anderson. The seven astronauts will work round-the-clock to complete a multidisciplinary research program involving 32 payloads with 59 separate investigations. Under an agreement with NASA, SPACEHAB, Inc. has marketed 18 percent of the module's capacity of 9,000 pounds to international and industry commercial users from around the world – NASA research will utilize the remaining 82 percent of the payload capacity.

Experiments in the SPACEHAB RDM include nine commercial payloads involving 21 separate investigations, four payloads for the European Space Agency with 14 investigations, one payload/investigation for ISS Risk Mitigation and 18 payloads supporting 23 investigations for NASA's Office of Biological and Physical Research (OBPR).

In the physical sciences, three studies inside a large, rugged chamber will examine the physics of combustion, soot production and fire quenching processes in microgravity. These experiments will provide new insights into combustion and fire-suppression that cannot be gained on Earth. An experiment that compresses granular materials, in the absence of gravity, will further our understanding of construction techniques. This information can help engineers provide stronger foundations for structures in areas where earthquakes, floods and landslides are common. Another experiment will evaluate the formation of zeolite crystals, which can speed the chemical reactions that are the basis for chemical processes used in refining, biomedical and other areas. Yet another experiment will use pressurized liquid xenon to mimic the behaviors of more complex fluids such as blood flowing through capillaries.

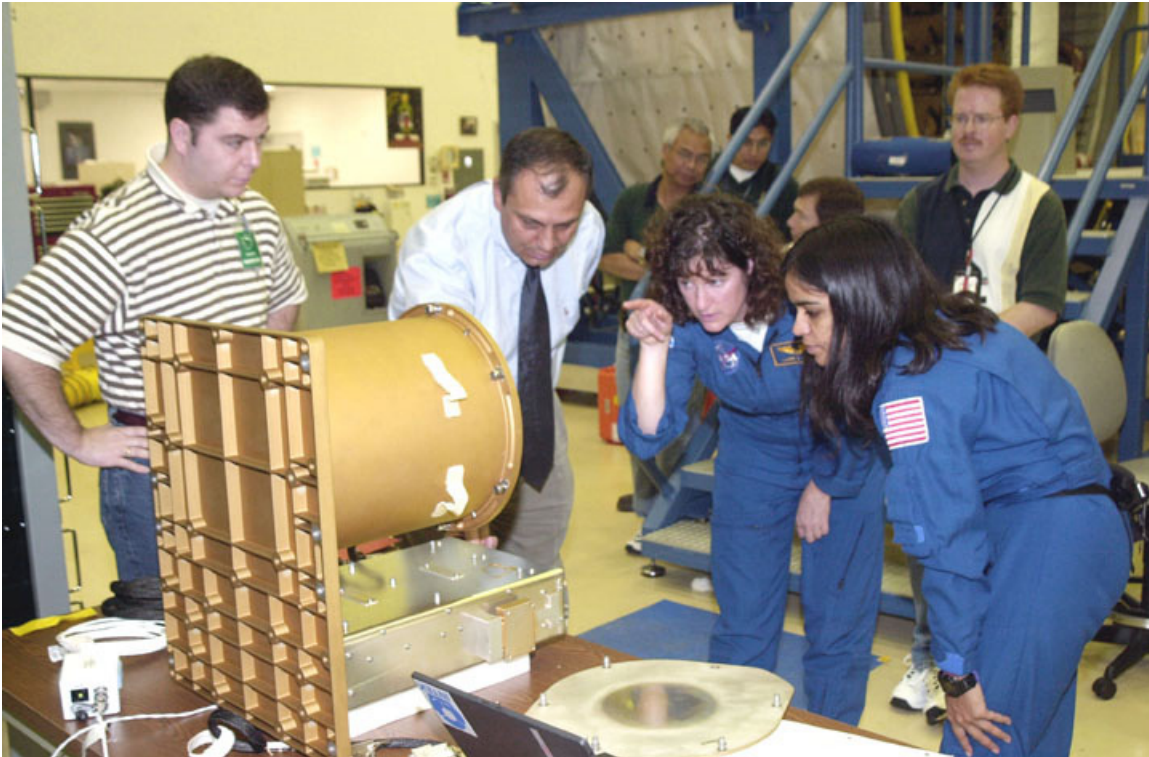

At SPACEHAB, Cape Canaveral, Fla., members of the STS-107 crew familiarize themselves with experiments and equipment for the mission. Pointing at a piece of equipment (center) is Mission Specialist Laurel Clark. At right is Mission Specialist Kalpana Chawla.

In the area of biological applications, two separate OBPR experiments will allow different types of cell cultures to grow together in weightlessness to enhance their development of enhanced genetic characteristics – one will be used to combat prostate cancer, the other to improve crop yield. Another experiment will evaluate the commercial usefulness of plant products grown in space. A facility for forming protein crystals more purely and with fewer flaws than is possible on Earth may lead to a drug designed for specific diseases with fewer side effects. A commercially sponsored facility will house two experiments to grow protein crystals to study possible therapies against the factors that cause cancers to spread and bone cancer to cause intense pain to its sufferers. A third experiment will look at developing a new technique of encapsulating anti-cancer drugs to improve their efficiency.

Other studies will focus on changes, due to spaceflight, in the cardiovascular and musculoskeletal systems; in the systems which sense and respond to gravity; and in the capability of organisms to respond to stress and maintain normal function. NASA is also testing a new technology to recycle water prior to installing a device to recycle water permanently aboard the International Space Station.



The European Space Agency (ESA), through a contract with SPACEHAB, is flying an important payload focused on astronaut health, biological function and basic physical phenomena in space. These experiments will address different aspects of many of the same phenomena that NASA is interested in, providing a more thorough description of the effects of spaceflight, often in the same subjects or specimens. ESA will perform seven in-flight experiments, and one ground-based, on the cardiopulmonary changes that occur in astronauts. Additional ESA biological investigations will examine bone formation and maintenance; immune system functioning; connective tissue growth and repair; and bacterial and yeast cell responses to the stresses of spaceflight. A special facility will grow large, well-ordered protein and virus crystals that are expected to lead to improved drug designs. Another will study the physical characteristics of bubbles and droplets in the absence of the effects of Earth's gravity.

SPACEHAB is also making it possible for universities, companies and other government agencies to do important research in space without having to provide their own spacecraft. The Canadian Space Agency is sponsoring three bone-growth experiments, and is collaborating with ESA on two others. The German Space Agency will measure the development of the gravity-sensing organs of fish in the absence of gravity. A university is growing ultra-pure protein crystals for drug research. Another university is testing a navigation system for future satellites. The U.S. Air Force is conducting a communications experiment. Students from six schools in Australia, China, Israel, Japan, Liechtenstein and the United States are probing the effects of spaceflight on spiders, silkworms, inorganic crystals, fish, bees and ants, respectively.

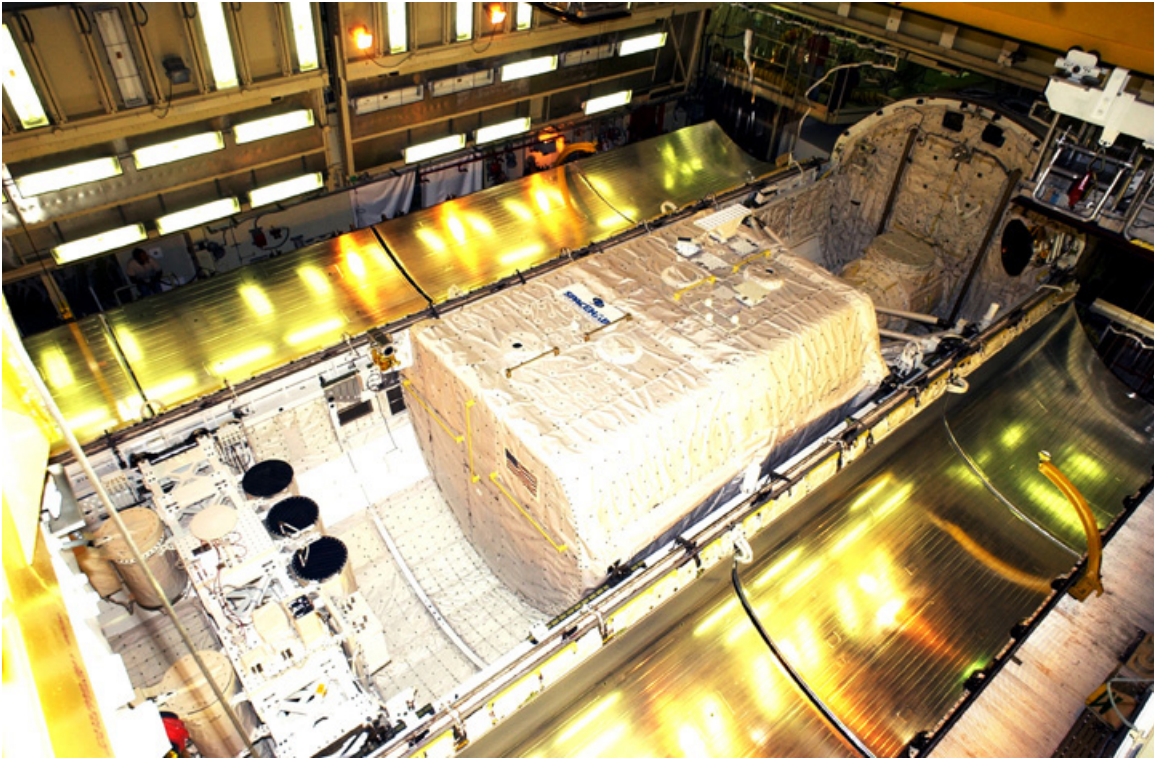

Columbia's payload bay doors are ready to be closed for mission STS-107. Installed inside are the Hitchhiker Bridge, a carrier for the Fast Reaction Experiments Enabling Science, Technology, Applications and Research (FREESTAR) that incorporates eight high priority secondary attached shuttle experiments, plus the SHI Research Double Module (SHI/RDM), also known as SPACEHAB.

There are also experiments in Columbia's payload bay, including three attached to the top of the RDM: the Combined Two-Phase Loop Experiment (COM2PLEX), Miniature Satellite Threat Reporting System (MSTRS) and Star Navigation (STARNAV). There are six payloads/experiments on the Hitchhiker pallet – the Fast Reaction Experiments Enabling Science, Technology, Applications and Research (FREESTAR), which is mounted on a bridge-like structure spanning the width of the payload bay. These six investigations look outward to the Sun, downward at Earth's atmosphere and inward into the physics of fluid phenomena, as well as testing technology for space communications.

FREESTAR will hold the Critical Viscosity of Xenon-2 (CVX-2), Low Power Transceiver (LPT), Mediterranean Israeli Dust Experiment (MEIDEX), Space Experiment Module (SEM-14), Solar Constant Experiment-3 (SOLCON-3) and Shuttle Ozone Limb Sounding Experiment (SOLSE-2). The SEM is made up of 11 separate student experiments from schools across the U.S. and is the 14th flight of a SEM on the space shuttle.

Additional secondary payloads are the Shuttle Ionospheric Modification with Pulsed Local Exhaust Experiment (SIMPLEX) and Ram Burn Observation (RAMBO).



Summary Timeline

(Last Updated: Dec. 8, 2002)

Below is a brief outline of what each STS-107 crewmember will be doing on any given Flight Day during their mission. For a more detailed overview of the daily activities of any crewmember, please see the daily Execute Package. Details on the various experiments, listed below by acronym, can be found in this press kit beginning on p. x or online at <http://spaceflight.nasa.gov/shuttle>

Common Experiment Acronyms:

ARMS - Advanced Respiratory Monitoring System

AST - Astroculture

BACTER - Bacterial Physiology & Virulence on Earth and in Microgravity (BIOPACK)

BDS - Biotechnology Demonstration System

BIOKN - microgravity influences on bacterial growth(BIOPACK)

BIOPACK - ESA facility to conduct biological experiments (eight total)

LSP - Laminar Soot Process (in Combustion Module)

MEIDEX - Mediterranean Israeli Dust Experiment (payload bay instrument)

MGM - Mechanics of Granular Materials

MIST - Water Mist Fire Suppression (in Combustion Module)

MPFE - Microbial Physiology Flight Experiments

PCBA - Portable Clinical Blood Analyzer

PhAB4 - Physiology and Biochemistry Team (four experiments)

SOFBALL - Structures of Flame Balls at Low Lewis-numbers (in Combustion Module)

SOLSE - Shuttle Ozone Limb Sounding Experiment (payload bay instrument)

STARS - Space Technology and Research Students (six international student experiments on Columbia's middeck)

STROM - bone marrow stromal cells (BIOPACK)

VCD - Vapor Compression Distillation

YSTRS - Yeast Cells Under Stress (BIOPACK)

ZCG - Zeolite Crystal Growth



FD1:

Blue Team:

McCool - post-launch activities, sleep

Brown - post-launch activities, sleep

Anderson - post-launch activities, sleep

Red Team:

Husband - Columbia post-launch configurations, SOLSE activation, attitude maneuvering

Chawla - Spacehab activation, BDS set-up

Clark - Spacehab activation; ARMS set-up and Rebreathe experiment

Ramon - Spacehab activation; MEIDEX set-up, ARMS set-up and Rebreathe experiment; PhAB4 set-up

FD2:

Blue Team:

McCool - Spacehab set-up, BIOPACK (Leukin) and MEIDEX

Brown - Spacehab set-up, ARMS (muscle), MEIDEX ops and PhAB4 set-up

Anderson - ARMS (rebreath and muscle), MEIDEX check-out, STARS activation and PhAB4 set-up

Red Team:

Husband - SOLSE

Chawla - ZCG, MGM, BIOPACK (bones) and BDS

Clark - BDS, AST, ZCG, OSTEO, CIBX and ARMS (muscle)

Ramon - PhAB4, MEIDEX, ARMS (muscle), AST and MPFE

FD3:

Blue Team:

McCool – PCBA, MEIDEX and ARMS

Brown - ARMS (pulmonary), PhAB4 and MEIDEX

Anderson - PhAB4 and ARMS (pulmonary)



Red Team:

Husband - MEIDEX, PCBA, various systems and experiments checks

Chawla – VCD, BDS, MGM set-up and activation, and ZCG

Clark - PhAB4, OSTEO and ARMS (pulmonary)

Ramon – AST, PhAB4, ARMS (pulmonary) and MPFE check

FD4:

Blue Team:

McCool - attitude maneuvering for MEIDEX

Brown - LSP, MEIDEX and PhAB4

Anderson - LSP, PhAB4 and PCBA

Red Team:

Husband - attitude maneuvering for MEIDEX and SOLSE

Chawla - LSP, VCD, AST, MGM and BIOPACK (Bones)

Clark – ZCG, PhAB4, BDS, VCD and CIBX

Ramon - PhAB4, MEIDEX, LSP, MPFE and PCBA

FD5:

Blue Team:

McCool - attitude maneuvering for SOLCON and MEIDEX, and PhAB4

Brown - LSP and MEIDEX

Anderson - LSP

Red Team:

Husband - attitude maneuvering for SOLCON and MEIDEX, and PhAB4

Chawla - attitude maneuvering, MGM, PhAB4, AST and LSP

Clark - BDS, VCD, AST, OSTEO and MPFE

Ramon - ZCG, LSP, MEIDEX, LSP and PCBA



FD6:

Blue Team:

McCool - attitude maneuvering for SOLSE, SOLCON and MEIDEX

Brown - LSP and MEIDEX

Anderson - LSP, MGM and PCBA

Red Team:

Husband - attitude maneuvering for SOLCON and SOLSE

Chawla - MEIDEX, ZCG, VCD, attitude maneuvering for SOLSE, and MGM

Clark - BDS, AST, VCD, OSTEO and BIOPACK (Bones)

Ramon - PhAB4 stow, LSP, MEIDEX, SOLSE and MPFE

FD7: (includes some off duty time for all seven crewmembers)

Blue Team:

McCool - SOLSE, attitude maneuvering for MEIDEX

Brown - MEIDEX

Anderson - LSP

Red Team:

Husband - attitude maneuvering

Chawla – LSP and SOFBALL

Clark - VCD, BDS, OSTEO and AST

Ramon - ZCG, LSP, MPFE and SOFBALL

FD8:

Blue Team:

McCool - attitude maneuvering for SOLCON and MEIDEX, and ARMS

Brown - SOFBALL and ARMS (pulmonary and muscle)

Anderson - SOFBALL and ARMS



Red Team:

Husband - attitude maneuvering for MEIDEX, and OSTEO

Chawla - MEIDEX, SOFBALL and VCD

Clark - ZCG, BDS, ARMS (pulmonary), MPFE, VCD and AST

Ramon - ARMS (pulmonary and muscle), MEIDEX and SOFBALL

FD9:**Blue Team:**

McCool - ARMS and attitude maneuvering for SOLSE, SOLCON and MEIDEX

Brown - SOFBALL and ARMS

Anderson - ARMS (pulmonary and muscle)

Red Team:

Husband - attitude maneuvering for SOLSE

Chawla - BDS, BIOPACK (Bacter), SOFBALL

Clark - ARMS (pulmonary and muscle), AST and OSTEO

Ramon - MEIDEX, SOFBALL, ARMS and AST

FD10:**Blue Team:**

McCool - attitude maneuvering for SOLCON and MEIDEX

Brown - SOFBALL and MEIDEX

Anderson - SOFBALL and MGM

Red Team:

Husband - attitude maneuvering for MEIDEX

Chawla - ZCG, MGM, SOFBALL and AST

Clark - BDS, BIOPACK (Bacter), OSTEO and MPFE

Ramon - SOFBALL



FD11:

Blue Team:

McCool - attitude maneuvering for MEIDEX, and BIOPACK (STROM, BIOKN and YSTRS)

Brown - SOFBALL and MEIDEX

Anderson - SOFBALL and MGM

Red Team:

Husband - attitude maneuvering for MEIDEX and SOLCON

Chawla - SOFBALL

Clark - BIOPACK (YSTRS), ZCG, BDS and PhAB4

Ramon - AST, MEIDEX, PhAB4 and PCBA

FD12:

Blue Team:

McCool - attitude maneuvering for SOLSE, and PCBA

Brown - SOFBALL, PhAB4, and attitude maneuvering

Anderson - PhAB4 and SOFBALL shutdown

Red Team:

Husband - orbiter systems and experiments checks, SOLSE, PCBA

Chawla - MIST and BDS

Clark - BDS, PhAB4, AST and MPFE deactivation

Ramon - MIST, MEIDEX and PhAB4

FD13: (includes some off duty time for all seven crewmembers)

Blue Team:

McCool - orbiter systems and experiments checks

Brown - PhAB4 and PCBA

Anderson - BCR, PhAB4 and MEIDEX



Red Team:

Husband - attitude maneuvering and PCBA

Chawla - MIST

Clark - ZCG, BDS and PhAB4

Ramon - PhAB4, MIST and AST

FD14:**Blue Team:**

McCool - BIOPACK (YSTRS), SOLSE, PhAB4 and PCBA

Brown - ARMS (pulmonary and muscle)

Anderson - MIST and ARMS

Red Team:

Husband - attitude maneuvering for MEIDEX, PCBA and PhAB4

Chawla - BDS and PhAB4

Clark - ARMS (pulmonary and muscle) and ZCG

Ramon - MEIDEX and ARMS

FD15:**Blue Team:**

McCool - ARMS, MIST, SOLSE and OMS engine burn

Brown - MIST, ARMS and PCBA

Anderson - ARMS (pulmonary and muscle) and MEIDEX

Red Team:

Husband - OMS engine burn and attitude maneuvering, SOLSE

Chawla - ZCG, OMS engine burn and MEIDEX

Clark - BDS, OMS engine burn and ARMS

Ramon - ARMS (pulmonary and muscle)



FD16:

Blue Team:

McCool - BIOPACK (YSTRS), SOLSE, attitude maneuvering, Flight Control System checkout and Reaction Control System hotfire

Brown - ARMS teardown and stow, MEIDEX, MIST shutdown and cabin stow

Anderson - MIST shutdown and cabin stow

Red Team:

Husband - Flight Control System checkout, Reaction Control System hotfire, attitude maneuvering and cabin stow

Chawla - Flight Control System checkout, attitude maneuvering for MEIDEX, cabin stow and ZCG stow

Clark - BDS, Flight Control System checkout, Reaction Control System hotfire, cabin stow, ZCG powerdown and PhAB4 stow

Ramon - cabin stow, MEIDEX and PhAB4 stow

FD17:

Blue Team:

McCool - Ku stow, ergometer stow, cabin stow, SOLSE deactivate, cabin stow, deorbit prep and landing

Brown - cabin stow, Spacehab teardown and entry prep, deorbit prep and landing

Anderson - cabin stow, Spacehab teardown and entry prep, deorbit prep and landing

Red Team:

Husband - deorbit prep and landing

Chawla - deorbit prep and landing

Clark - deorbit prep and landing

Ramon - deorbit prep and landing



Mission Profile

Crew

Commander:	Rick D. Husband
Pilot:	William C. McCool
Mission Specialist 1:	David M. Brown
Mission Specialist 2:	Kalpana Chawla
Mission Specialist 3:	Michael P. Anderson (Payload Commander)
Mission Specialist 4:	Laurel B. Clark
Payload Specialist:	Ilan Ramon

Launch

Orbiter:	Columbia (OV-102)
Launch Site:	Kennedy Space Center Launch Pad 39A
Launch Window:	2.5 Hours
Altitude:	150 Nautical Miles
Inclination:	39 Degrees
Duration:	15 Days, 22 Hours, 17 Minutes

Vehicle Data

Shuttle Liftoff Weight:	452,842 lbs.
Orbiter/Payload Liftoff Weight:	263,701 lbs.
Orbiter/Payload Landing Weight:	232,788 lbs.
Software Version:	OI-29



Space Shuttle Main Engines:

SSME 1: 2055

SSME 2: 2053

SSME 3: 2049

External Tank: ET-93A (Super Light Weight Tank)

SRB Set: BI116PF

Shuttle Aborts

Abort Landing Sites

RTLS: Kennedy Space Center Shuttle Landing Facility

TAL: Primary – Moron; Alternates Zaragoza, Ben Guerir

AOA: Edwards Air Force Base, California

Landing

Landing Date: February 1, 2003

Primary Landing Site: Kennedy Space Center Shuttle Landing
Facility



Crewmembers

Commander: Rick D. Husband



Rick Husband, 45, a colonel in the U.S. Air Force, is a test pilot and veteran of one spaceflight. He will serve as commander for STS-107. Husband received a bachelor of science in mechanical engineering from Texas Tech University in 1980 and a master of science in mechanical engineering from California State University-Fresno in 1990. As commander, Husband will be responsible for the overall conduct of the mission. During the mission, he will be maneuvering Columbia as part of several experiments in the shuttle's payload bay that will focus on the Earth and the Sun. He will also be the senior member of the Red Team and will work with the following experiments: European Research In Space and Terrestrial Osteoporosis (ERISTO); Mediterranean

Israeli Dust Experiment (MEIDEX); Osteoporosis Experiment in Orbit (OSTEO); the Physiology and Biochemistry Team (PhAB4) suite of experiments, which includes Calcium Kinetics, Latent Virus Shedding, Protein Turnover and Renal Stone Risk; and Shuttle Ozone Limb Sounding Experiment (SOLSE-2). Husband will also land Columbia at the end of the mission.

Selected by NASA in December 1994, Husband served as the pilot of STS-96 in 1999 - a 10-day mission during which the crew performed the first docking with the International Space Station. He has logged more than 235 hours in space.



Pilot: William C. McCool



William C. McCool, 41, a commander in the U.S. Navy, is a former test pilot. He will serve as pilot for STS-107. He received a bachelor of science in applied science from the U.S. Naval Academy in 1983, a master of science in computer science from the University of Maryland in 1985, and a master of science in aeronautical engineering from the U.S. Naval Postgraduate School in 1992. McCool, as a member of the Blue Team, will work with the following experiments: European Space Agency (ESA) Advanced Respiratory Monitoring System (ARMS); ESA Biopack (eight experiments); Mediterranean Israeli Dust Experiment (MEIDEX); and the Physiology and Biochemistry Team (PhAB4) suite of experiments, which includes Calcium Kinetics, Latent Virus Shedding, Protein

Turnover and Renal Stone Risk. He will also be responsible for maneuvering Columbia as part of several experiments mounted in the shuttle's payload bay.

Selected by NASA in April 1996, McCool will be making his first spaceflight.



Payload Commander: Michael P. Anderson



Michael P. Anderson, 43, a lieutenant colonel in the U.S. Air Force, is a former instructor pilot and tactical officer, and a veteran of one spaceflight. He will serve as Payload Commander and Mission Specialist 3 for STS-107. As payload commander he is responsible for the success (management) of the science mission aboard STS-107. Anderson received a bachelor of science in physics/astronomy from University of Washington in 1981 and a master of science in physics from Creighton University in 1990. Anderson, as a member of the Blue Team, will work with the following experiments: European Space Agency Advanced Respiratory Monitoring System (ARMS); Combustion Module (CM-2), which includes the Laminar Soot

Processes (LSP), Water Mist Fire Suppression (MIST) and Structures of Flame Balls at Low Lewis-number (SOFBALL) experiments; Mediterranean Israeli Dust Experiment (MEIDEX); Mechanics of Granular Materials (MGM); and the Physiology and Biochemistry Team (PhAB4) suite of experiments, which includes Calcium Kinetics, Latent Virus Shedding, Protein Turnover and Renal Stone Risk.

Selected by NASA in December 1994, Anderson flew on STS-89 in 1998 - the eighth Shuttle-Mir docking mission. Anderson has logged over 211 hours in space.



Mission Specialist 1: David M. Brown



David M. Brown, 46, a captain in the U.S. Navy, is a naval aviator and flight surgeon. He will serve as Mission Specialist 1 for STS-107. Brown received a bachelor of science in biology from the College of William and Mary in 1978 and a doctorate in medicine from Eastern Virginia Medical School in 1982. Brown, as a member of the Blue Team, will work with the following experiments: European Space Agency Advanced Respiratory Monitoring System (ARMS); Combustion Module (CM-2), which includes the Laminar Soot Processes (LSP), Water Mist Fire Suppression (MIST) and Structures of Flame Balls at Low Lewis-number (SOFBALL) experiments; Mediterranean Israeli Dust Experiment (MEIDEX); and the Physiology and Biochemistry Team (PhAB4) suite of experiments, which includes Calcium

Kinetics, Latent Virus Shedding, Protein Turnover and Renal Stone Risk.

Selected by NASA in April 1996, Brown will be making his first spaceflight.



Mission Specialist 2: Kalpana Chawla



Kalpana Chawla, 41, is an aerospace engineer and an FAA Certified Flight Instructor. Chawla will serve as Flight Engineer and Mission Specialist 2 for STS-107. She received a bachelor of science in aeronautical engineering from Punjab Engineering College, India, in 1982, a master of science in aerospace engineering from the University of Texas-Arlington in 1984, and a doctorate in aerospace engineering from the University of Colorado-Boulder in 1988. As a member of the Red Team, Chawla, with CDR Rick Husband, will be responsible for maneuvering Columbia as part of several experiments in the shuttle's payload bay. Chawla will also work with the following experiments: Astroculture (AST);

Advanced Protein Crystal Facility (APCF); Commercial Protein Crystal Growth (CPCG_PCF); Biotechnology Demonstration System (BDS); ESA Biopack (eight experiments); Combustion Module (CM-2), which includes the Laminar Soot Processes (LSP), Water Mist Fire Suppression (MIST) and Structures of Flame Balls at Low Lewis-number (SOFBALL) experiments; Mechanics of Granular Materials (MGM); Vapor Compression Distillation Flight Experiment (VCD FE); and the Zeolite Crystal Growth Furnace (ZCG).

Selected by NASA in December 1994, Chawla was the prime robotic arm operator on STS-87 in 1997, the fourth U.S. Microgravity Payload flight. STS-87 focused on how the weightless environment of space affects various physical processes. Chawla has logged more than 376 hours in space.



Mission Specialist 4: Laurel Blair Salton Clark



Laurel Clark, 41, a commander (captain-select) in the U.S. Navy and a naval flight surgeon, will be Mission Specialist 4 on STS-107. Clark received a bachelor of science in zoology from the University of Wisconsin-Madison in 1983 and a doctorate in medicine from the same school in 1987. Clark, as a member of the Red Team, will work with the following experiments: European Space Agency (ESA) Advanced Respiratory Monitoring System (ARMS); Astroculture (AST-1 and 2); Biotechnology Demonstration System (BDS); ESA Biopack (eight experiments); Application of Physical & Biological Techniques to Study the Gravisensing and Response System of Plants: Magnetic Field Apparatus

(Biotube-MFA); Closed Equilibrated Biological Aquatic System (CEBAS); Commercial ITA Biological Experiments (CIBX); the Microbial Physiology Flight Experiments Team (MPFE) experiments, which include the Effects of Microgravity on Microbial Physiology and Spaceflight Effects on Fungal Growth, Metabolism and Sensitivity to Antifungal Drugs; Osteoporosis Experiment in Orbit (OSTEO); the Physiology and Biochemistry Team (PhAB4) suite of experiments, which includes Calcium Kinetics, Latent Virus Shedding, Protein Turnover and Renal Stone Risk; Sleep-Wake Actigraphy and Light Exposure During Spaceflight (SLEEP); and the Vapor Compression Distillation Flight Experiment (VCD FE).

Selected by NASA in April 1996, Clark will be making her first spaceflight.



Payload Specialist 1: Ilan Ramon



Ilan Ramon, 48, a colonel in the Israeli Air Force, is a fighter pilot who will be the only payload specialist on STS-107. Ramon received a bachelor of science in electronics and computer engineering from the University of Tel Aviv, Israel, in 1987. Ramon, as a member of the Red Team, will be the prime crewmember for the Mediterranean Israeli Dust Experiment (MEIDEX), a multispectral camera that will measure small dust particles (dust aerosols) in the atmosphere over the Mediterranean and the Saharan coast of the Atlantic. He will also be working with the following experiments: European Space Agency Advanced Respiratory Monitoring System (ARMS); Astroculture (AST-1 and 2); Biological Research in Canister - Development of Gravity Sensitive Plant Cells in Microgravity (BRIC); Combustion

Module (CM-2), which includes the Laminar Soot Processes (LSP), Water Mist Fire Suppression (MIST) and Structures of Flame Balls at Low Lewis-number (SOFBALL) experiments; the Microbial Physiology Flight Experiments Team (MPFE) experiments, which include the Effects of Microgravity on Microbial Physiology and Spaceflight Effects on Fungal Growth, Metabolism and Sensitivity to Anti-fungal Drugs; the Physiology and Biochemistry Team (PhAB4) suite of experiments, which includes Calcium Kinetics, Latent Virus Shedding, Protein Turnover and Renal Stone Risk; and Space Technology and Research Students Bootes (STARS Bootes).

Ramon was selected as a Payload Specialist by the Israeli Air Force in 1997 and approved by NASA in 1998. He reported for training at the NASA Johnson Space Center in Houston in July 1998 and will be making his first spaceflight.



Payloads

SPACEHAB Research Double Module (RDM)

SPACEHAB Inc.'s Research Double Module (RDM) is making its first flight on STS-107. The RDM is a pressurized aluminum habitat that is carried in the space shuttle's cargo bay to expand working space aboard the shuttle. The RDM is connected to the shuttle middeck by a pressurized access tunnel. Boeing-Huntsville performed the RDM's systems integration for SPACEHAB and serves as the company's mission integration contractor. SPACEHAB Single Modules outfitted for research or logistics and Double Modules outfitted for logistics have flown on 15 space shuttle missions to date.



The SPACEHAB Research Double Module (RDM) and pressurized access tunnel are lowered toward Columbia's payload bay.

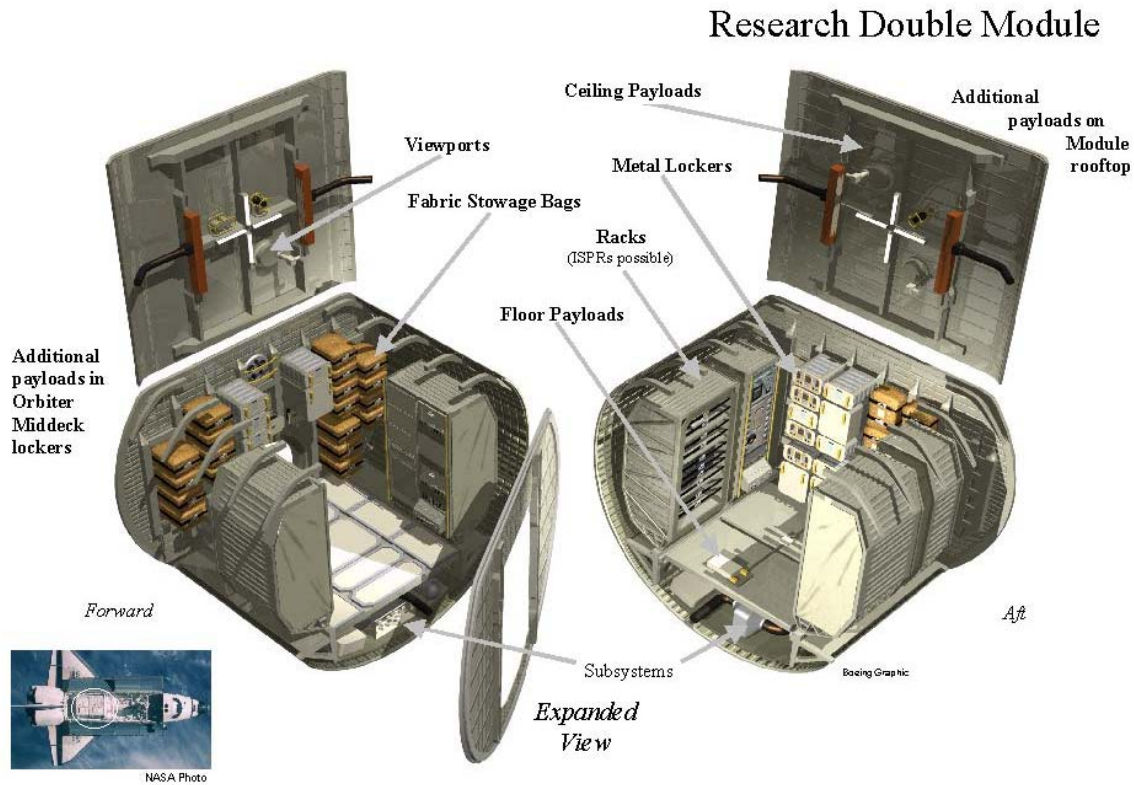

The RDM is approximately 20 feet long, 14 feet wide, and 11 feet high. Outfitted as a state-of-the-art laboratory, it has a pressurized volume of 2,200 cubic feet and can hold up to 61 space shuttle middeck lockers (up to 60 pounds and 2 cubic feet each) plus six Double Racks (1,400 pounds and 45 cubic feet each). The RDM also can accommodate International Space Station Payload Racks (ISPRs). The Module has two viewports and can carry powered rooftop payloads (three on STS-107) using feed-through plates in the module ceiling. The RDM, which has a payload capacity of 9,000 pounds, will carry about 7,500 pounds of research payloads on STS-107. An additional 800 pounds of SPACEHAB-integrated payloads are flying on the shuttle middeck, making a total of 8,300 pounds of research payloads on STS-107.



STS-107 crewmembers check out equipment in the SPACEHAB RDM. Mission Specialist Kalpana Chawla (left) holds a data manual while Mission Specialist David Brown stretches out on the floor to get a closer look during the Crew Equipment Interface Test activities, which include equipment and payload familiarization.

The RDM provides investigators with the latest in telemetry and command control capabilities that are compatible with the International Space Station. The Module provides payload data downlink services via the shuttle's Ku-band communication system, increasing available downlink bandwidth up to 25 Mbps. It is equipped with an enhanced environmental control system designed for a four-person load capability, a key requirement to support round-the-clock crew operations on STS-107.

The Module provides AC and DC power plus air and water cooling for experiments. STS-107 payloads using time-critical components, such as biological samples, require access to the RDM for loading as late as L-31 hours before launch. SPACEHAB will be loading approximately 40 percent of the payloads for STS-107 on the RDM after the Module is installed in the shuttle cargo bay and the shuttle is on the launch pad.



STS-107 Payload Commander Michael Anderson checks equipment during training at SPACEHAB.

SPACEHAB's flight services contract with NASA provides the company with 12 percent of the RDM's payload capacity to sell to commercial customers on STS-107.

SPACEHAB's commercial payloads on the mission include:

- * **Advanced Respiratory Monitoring System (ARMS), European Space Agency:** ARMS is an investigation of pulmonary and cardiovascular changes in humans during rest and exercise in early and later phases of spaceflight. The ARMS facility measures gas compositions during inspiration and expiration of different gas mixtures, heart rate, blood pressure and respiratory rate. STS-107 is the first flight of ARMS. For more information, see the ARMS section in this press kit.
- * **Closed Equilibrated Biological Aquatic System (CEBAS), DLR (German Space Agency):** CEBAS, a middeck payload, is a habitat for aquatic organisms and serves as a facility for conducting microgravity experiments in zoology, botany, developmental biology and ecosystems research. CEBAS flew on STS-89 and STS-90.



- * **Miniature Satellite Threat Reporting System (MSTRS), U.S. Air Force:**
This payload is a communications technology demonstration developed by the Air Force Research Laboratory in Albuquerque, N.M. STS-107 is the first flight of MSTRS.
- * **Commercial Macromolecular Protein Crystal Growth (CMPCG), University of Alabama-Birmingham Center for Biophysical Science and Engineering (UAB CBSE) and SPACEHAB:** CPMG is a commercial facility sponsored by SPACEHAB, which has partnered with UAB CBSE to use the CMPCG facility for the production of large, high-quality protein crystals under controlled conditions in microgravity. Primary customers are the National Space Development Agency of Japan, Canadian Space Agency, and Donald Danforth Plant Science Center.
- * **Combined 2-Phase Loop Experiment (COM2PLEX), European Space Agency:** The COM2PLEX rooftop test facility is designed to investigate the behavior of capillary-pumped loops in microgravity. The facility will demonstrate three different two-phase loops by transporting different amounts of heat from evaporator to condenser and radiating heat into space. STS-107 is the first flight of COM2PLEX.
- * **STARS-Bootes:** For information see the STARS Student Experiments.
- * **STARNAV Star Navigation Experiment, Texas A&M University:**
This experiment, a rooftop payload, is designed to validate a new algorithm for determining precise spacecraft attitude without prior knowledge of position and develop educational interest in space technology and astronomy.
- * **Osteoporosis Experiment in Orbit (OSTEO), Canadian Space Agency:**
OSTEO is an in-vitro evaluation of bone cell activity in microgravity. Baseline bone cell activity and the effects of specific pharmaceutical agents will be assessed. This payload flew on STS-95.
- * **European Research In Space and Terrestrial Osteoporosis (ERISTO), European Space Agency in coordination with the Canadian Space Agency:** ERISTO, an in-vitro evaluation of bone cell activity in microgravity, uses the same facility hardware as the OSTEO experiment. STS-107 is the first flight of ERISTO.



- * **Physiology and Biochemistry 4 (JSC-HLS/PhAB4), NASA Johnson Space Center:** This experiment package includes four life science investigations - Protein Turnover During Spaceflight, Calcium Kinetics During Spaceflight, Renal Stone Risk, and Viral Shedding. Experiment hardware includes blood collection kits; urine collection kits; saliva collection kits; tracer kits; a Portable Clinical Blood Analyzer; an Orbiter Centrifuge; an Enhanced Orbiter Refrigerator/Freezer (EOR/F) that flew on STS-55, STS-58, STS-71, STS-74, STS-84, STS-89, and STS-95; and a Thermoelectric Holding Module (TEHM) that made multiple flights on the space shuttle middeck and is flying for the first time in a SPACEHAB Module on STS-107.

For more information visit:

<http://www.spacehab.com/sts107>

STS-107 Master Experiment List

Biology

Biological

Cardiovascular/cardiopulmonary

- 2-DK, Effects of Microgravity on Total Peripheral Vascular Resistance in Humans, Peter Norsk, M.D., Ph.D., DAMEC Research, Copenhagen, Denmark, ESA
- 4-I, Arterial Baroreflex Control of Sinus Node during Exercise in Microgravity Conditions, Fernando Iellamo, M.D, Univ, of Rome Tor Vergata, Rome, Italy, ESA
- 8-D, Influence of Weightlessness on Heart Rate & Blood Pressure Regulation—Responses to Exercise & Valsalva Maneuver, Uwe Hoffmann, Ph.D., Deutsche Sport Hochschule, Cologne, Germany, ESA
- 9-NL, Physiological Parameters that Predict Orthostatic Intolerance After Spaceflight, John Karamaker, Ph.D., Univ, of Amsterdam, Amsterdam, Netherlands, ESA
- 11-DK, Initial Effects of Microgravity on Central Cardiovascular Variables in Humans, Regitze Videbaek, M.D., Univ, Hospital Copenhagen, Copenhagen, Denmark, ESA
- 12-I, Adaptation of Spontaneous Baroreflex Sensitivity to Microgravity, Marco Di Rienzo, Ph.D., Centro di Bioingegneria LaRC, Milano, Italy, ESA
- E386, Arterial Remodeling and Functional Adaptations Induced by Microgravity, Michael Delp, Ph.D., Texas A&M University, College Station, TX, NASA

Gravito-inertial sensitivity

- BRIC-14, Development of Gravity Sensitive Plant Cells in Microgravity, Fred D, Sack, Ph.D., OH State Univ., Columbus, OH, NASA
- CEBAS, Fish Otolith Growth and Development of Otolith Asymmetry at Microgravity, H, Rahmann and R, Anken, Univ, of Stuttgart-Hohenheim, Stuttgart, Germany, DLR
- DSO 635 & E118, Spatial Reorientation Following Spaceflight, William Paloski, Ph.D., NASA Johnson Space Center, Houston, TX, NASA
- E127, Anatomical Studies of Central Vestibular Adaptation, Gay R, Holstein, Ph.D., Mt, Sinai Medical Center, New York, NY, NASA
- MFA, Application of Physical & Biological Techniques to study the Gravisensing and Response System of Plants, Karl H, Hasenstein, Ph.D., University of Louisiana - Lafayette, Lafayette, LA, NASA

Musculo-skeletal

- 7-S, Cardiopulmonary & Muscular Adaptations During & After Microgravity, Dag Linnarsson, M.D., Ph.D., Karolinska Institute, Stockholm, Sweden, ESA
- BONES, The Role of Bone Cells in the Response of Skeletal Tissues in Microgravity, J.P, Velduijzen, ACTA Vrije University, Amsterdam, The Netherlands, ESA
- CONNECT, Function of the Focal Adhesion of Plaque of Connective Tissue in Microgravity, Ch.-M, Lapiere and A, Kholti, University of Liege, Liege, Belgium, ESA
- E048, Protein Turnover During Spaceflight, Army Ferrando, Ph.D., Univ, of TX Medical Branch/Shriners Burns Institute, Galveston, TX, NASA
- E381S, Calcium Kinetics During Spaceflight, Scott M, Smith, Ph.D., NASA Johnson Space Center, Houston, TX, NASA
- OBLAST, Comparative Analysis of Osteoblastic (bone-forming) Cells at Microgravity and 1G, C, Alexandre, Paris, Paris, France, ESA
- OCLAST, Microgravity Effects on Osteoclast (bone-removing) Driven Resorption in vitro, A, Zallone, Bari, Bari, Italy, ESA
- OSMIN, Osteoblasts in Space, Dr, L, Vico, Mr, A, Guignandon, LBBTO, St, Etienne, France, ESA
- OSPACE, Osteoclasts in Space, Prof, A, Zallone, Dr, Mori, Univ, of Bari, Bari, Italy, ESA
- OSTEOGENE, Identification of Microgravity-Related Genes in Osteoblastic Cells, R, Bouillon, Leuven, Leuven, Italy, ESA
- [bone gene regulation], Osteoporosis Experiment in Orbit, Dennis R, Sindrey, NPS Allelix, Mississauga, Ont., Canada, CSA
- [hormones and osteoblasts], Osteoporosis Experiment in Orbit, Dr, Leticia G, Rao, St, Michael's Hospital, Toronto, Ont., Canada, CSA
- [sleep & immune effects on bone], Osteoporosis Experiment in Orbit, Dr, Reginald M, Gorczynski & Dr, Harvey Moldofsky, University Health Network, Toronto, Ont., Canada, CSA

Stress responses, homeostasis and integrative physiology/Educational

- Ant Colony, students, G.W, Fowler High School, Syracuse, NY, Syracuse University plus local corporate sponsors
- Astrospiders—Spiders in Space, students, Glen Waverley Secondary College, Royal Melbourne Institute of Technology, Royal Melbourne Zoo, Melbourne, Australia, RMIT, RMZ
- Carpenter Bees In Space, students, Form 4a, Liechtensteinisches Gymnasium, Vaduz, Liechtenstein, Liechtensteinische VP Bank
- Flight of the Medaka Fish, Maki Niihori (biology student), Ochanomizu University, Tokyo, Japan, Japan Space Utilization Promotion Center (JSUP)
- Silkworm Lifecycle During Space Flight, students (initiator: 5th grade student Li Taotao), Jingshan School, Beijing, China, China Time Network Co, Ltd.

Stress responses, homeostasis and integrative physiology

- 10-I, Multiparametric Assessment of the Stress Response in Astronauts During Spaceflight, Massimo Pagani, M.D., Ph.D., University of Milan, Milan, Italy, ESA
- BACTER, Bacterial Physiology and Virulence on Earth and in Microgravity, Barry H, Pyle, Ph.D., Montana State University, Bozeman, MT, NASA
- BDS-05, Biotechnology Cell Science Payload (Bioreactor), Leland Cheung, Emory University, Atlanta, GA, NASA
- BIOKIN-3, Determination of the Space Influence on Bacterial Growth Kinetics, J, van der Waarde, Bioclear B.V., University of Gronigen, Gronigen, The Netherlands, ESA
- CEBAS, Immunological Investigations with *Xiphophorus helleri*, R, Goerlich, Univ, of Dusseldorf, Dusseldorf, Germany, DLR
- CEBAS, Plant Physiological Experiments with *Ceratophyllum demersum*, H, Levine, Dynamac Corp., Kennedy Space Center, FL, DLR
- CEBAS, Reproductive Biological and Embryological Research in *Xiphophorus helleri*, V, Bluem, Ruhr University, Bochum, Germany, DLR
- DSO 632B, Pharmacokinetics & Contributing Physiologic Changes During Spaceflight, Lakshmi Putcha, Ph.D., NASA Johnson Space Center, Houston, TX, NASA
- E057, Renal Stone Risk During Spaceflight: Assessment and Countermeasure Validation, Peggy A, Whitson, Ph.D., NASA Johnson Space Center, Houston, TX, NASA
- E210, Flight Induced Changes in Immune Defenses, Duane Pierson, Ph.D., NASA Johnson Space Center, Houston, TX, NASA
- E240, Spaceflight Effects on Fungal Growth, Metabolism, and Sensitivity to Antifungal Drugs, Michael R, McGinnis, Ph.D., Univ, of TX Medical Branch, Galveston, TX, NASA
- E394, Sleep-Wake Actigraphy and Light Exposure During Spaceflight, Charles A, Czeisler, Ph.D., M.D., Brigham and Women's Hospital, Harvard Medical School, Cambridge, Mass., NASA
- 98-E409, Choroidal Regulation Involved in the Cerebral Fluid Response to Altered Gravity, Jacqueline Gabrion, Ph.D., Institut des Neurosciences, Centre National de Recherche Scientifique, Paris, France, CNES
- E409, Incidence of Latent Virus Shedding During Spaceflight, Duane Pierson, Ph.D., NASA Johnson Space Center, Houston, TX, NASA
- E562, Effects of Microgravity on Microbial Physiology, Randolph W, Schweickart, Ph.D., ICOS Corp., Bothell, WA, NASA
- LEUKIN, Role of Interleukin-2 Receptor in Signal Transduction and Gravisensing Threshold in T-Lymphocytes, A, Cogoli, ETH, Zurich, Switzerland, ESA
- RADCELLS, Biological Dosimetry in Space Using Haemopoietic Stem Cell Functions, P.v, Oostveldt & A, Poffijn, Gent, Gent, Belgium, ESA
- REPAIR, Fidelity of DNA Double-Strand Break Repair in Human Cells Under Microgravity, J, Kiefer, University of Giessen, Giessen, Germany, ESA
- STROMA, Bone Marrow Stromal Cells Differentiation and Mesenchymal Tissue Reconstruction in Microgravity, R, Cancedda, University of Genova, Genova, Italy, ESA
- YSTRES, Yeast Cell Stress Under Microgravity, I, Walther, ETH, Zurich, Switzerland, ESA

Support systems

- Ergometer & Advanced Respiratory Monitoring System, ESA
- EOR/F, Enhanced Orbiter Refrigerator/Freezer, NASA Johnson Space Center, Houston, TX, NASA
- TEHM, Thermoelectric Holding Module, NASA Johnson Space Center, Houston, TX, NASA

Note: This is a complete listing of experiments planned for STS-107. It includes non-NASA government, commercial, and international payloads. The subheadings reflect a general breakdown and not the managerial divisions that NASA

employs for its own payloads. In general, each listing gives the acronym name likely to be used during air-to-ground conversations, the formal title, the name and affiliation of the principal investigator(s), and the payload sponsor.

Earth & Space Sciences

Atmospheric

MEIDEX, Mediterranean Israeli Dust Experiment, Joachim H. Joseph, Ph.D., Tel Aviv Univ., Tel Aviv, Israel, NASA
SIMPLEX, Shuttle Ionospheric Modification with Pulsed Local Exhaust Experiment, USA, Space Test Program, Kirtland AFB, Albuquerque, NM, USA
SOLSE-2, Shuttle Ozone Limb Sounding Experiment, Dr. Ernest Hilsenrath and

Dr. Richard McPeters, NASA Goddard Space Flight Center, Greenbelt, MD USA, NASA

Solar

SOLCON-3, Solar Constant Experiment, Dr. Alexandre Joukoff, Royal Meteorological Institute of Belgium, Brussels, Belgium, NASA

Physical Sciences

Crystallography and Molecular Structure/Educational

The Chemical Garden, 35 @ 8th-grade students, ORT Kiryat Motzkin Middle School (teacher: Dr. Birnbaum), Technion University (Prof. Eliezer Kolodne), Kiryat Motzkin, Israel, Technion University, Haifa

APCF, X-Ray Crystallography at Atomic Resolution, Molecular Mechanism of Ca/Mg Exchange with the EF-Hand Parvalbumin, J.P. Declercq, University of Louvain, Louvain, Belgium, ESA

Crystallography and Molecular Structure

APCF (Advanced Protein Crystallization Facility), Crystal Structure Analysis of the Outer Surface Glycoprotein of the Hyperthermophile Methanothermus Fervidus, J.P. Declercq, University of Louvain, Louvain, Belgium, ESA
APCF, Crystallization of Enzyme and Substrate-Analog Complexes for Highest Resolution Data Collection and Refinement, C. Betzel, University of Hamburg, Hamburg, Germany, ESA
APCF, Crystallization of Photosystem I under Microgravity, P. Fromme, University of Berlin, Berlin, Germany, ESA
APCF, Effect of Different Conditions on the Quality of Thaumatin and Aspartyl-tRNA Synthetase Crystals Grown in Microgravity, R. Giege & N. Lorber, Institut de Biologie Moleculaire et Cellulaire du CNRS, Paris, France, ESA
APCF, Solution Flows and Molecular Disorder of Protein Crystals Growth of Ferritin Crystals, S. Weinkauff, University of Munich, Munich, Germany, ESA
APCF, Testing New Trends in Microgravity Protein Crystallization: Comparison of Long Chambers With and Without Capillaries, J.M. Garcia-Ruiz & S. Weinkauff, University of Granada & University of Munich, Granada & Munich, Spain & Germany, ESA
APCF, Testing New Trends in Microgravity Protein Crystallization: Solution Flows and Molecular Disorder of Protein Crystals - Growth of High-quality Crystals and Motions of Lumazine Crystals, J.M. Garcia-Ruiz & S. Weinkauff, University of Granada & University of Munich, Granada & Munich, Spain & Germany, ESA

Physical processes

CVX-2, Critical Viscosity of Xenon-2, Robert F. Berg, Ph.D., National Institute of Standards and Technology, Gaithersburg, MD, NASA
FAST, Adsorption Dynamics and Transfer at Liquid/Liquid Interfaces, L. Liggieri +3, ICFAM-CNR, Genova, Italy, ESA
FAST, Dilational Properties of Interfaces, R. Miller +2, MPI-KG, Berlin, Germany, ESA
FAST, Interfacial Rheology and the Effects of Vibrations on Interfacial Properties, G. Loglio +2, UFIR-DCO & IROE-CNR, Firenze, Italy, ESA
LSP, Laminar Soot Processes, G.M. Faeth, Ph.D., Univ. of Michigan, Ann Arbor, MI, NASA
MGM, Mechanics of Granular Materials, Stein Sture, Ph.D., Dept. of Civil, Environmental and Architectural Engineering, Univ. of Colorado at Boulder, Boulder, Colorado, NASA
SOFBALL, Structures of Flame Balls at Low Lewis-number, Paul D. Ronney, Ph.D., University of Southern CA, Los Angeles, CA, NASA

Support systems

SAMS-FF, Space Acceleration Measurement System Free Flyer. Robert J. Sicker, NASA Glenn Research Center. Cleveland, OH, NASA
OARE, Orbiter Acceleration Research Experiment. Robert J. Sicker, NASA Glenn Research Center. Cleveland, OH, NASA

Space Product Development

Biological processes

AST 10/1, Astroculture™ 10/1, Plant Growth Experiment, Dr. Weija Zhou, Wisconsin Center for Space Automation and Robotics, College of Engineering, Univ. of Wisconsin, Madison, Madison, Wisconsin, NASA
AST 10/2, Astroculture™ 10/2, Gene Transfer Experiment, Dr. Weija Zhou, Wisconsin Center for Space Automation and Robotics, College of Engineering, Univ. of Wisconsin, Madison, Madison, WI, NASA

CPCG-PCF, Commercial Protein Crystal Growth-Protein Crystal Facility, Larry DeLucas, Ph.D., Center for Biophysical Sciences and Engineering (CBSE), University of AL-Birmingham, Birmingham, AL, NASA

Crystallography and Molecular Structure

CIBX-2, Commercial ITA Biological Experiments-2, Bence Jones Protein Crystal Growth Project, Dr. Allen Edmundson, Oklahoma Medical Research Foundation, Oklahoma City, OK, NASA
CIBX-2, Commercial ITA Biological Experiments-2, Urokinase Protein Crystal Growth Project, ITA, Instrumentation Technology Associates, Inc., Exton, PA, NASA
CMPCG, Commercial Macromolecular Protein Crystal Growth, L. DeLucas, Ph.D., University of AL-Birmingham and seven others, Birmingham, AL, NASA

Drug Delivery

CIBX-2, Commercial ITA Biological Experiments-2, Microencapsulation of Drugs, Dr. Denis Morrison, NASA Johnson Space Center, Institute for Research, Inc., and ITA Inc., Houston, TX, and Exton, PA, NASA

Physical processes

Mist, Water Mist Fire Suppression Experiment, J. Thomas McKinnon, Ph.D., Center for Commercial Applications of Combustion in Space (CCACS), Colorado School of Mines, Golden, Colorado, NASA
ZCG, Zeolite Crystal Growth Furnace, Albert Sacco, Ph.D., Center for Advanced Microgravity Materials Processing (CAMMP), Northeastern Univ., Boston, MA, NASA

Technology Development

Attitude Control

STARNAV, Star Navigation, Texas A&M University, College Station, TX, CSCE/SPACEHAB

Communications

LPT, Low Power Transmitter, NASA Glenn Research Center, Cleveland, OH, NASA
MSTRS, Miniature Satellite Threat Reporting System, Patrick Serna, Air Force Research Laboratory, Albuquerque, NM, U.S. Air Force

Educational

SEM-14, Space Experiment Module, 11 elementary and middle schools, Houston, TX, NASA
Environmental control
VCD, Vapor Compression Distillation Flight Experiment, NASA Johnson Space Center, Houston, TX, NASA
COM2PLEX, Combined Two-Phase Loop Experiment, Reinhard Schlitt, OHB GmbH, Bremen, Germany, ESA

Satellite sensor calibration

RAMBO, Ram Burn Observation, USAF Space and Missile Center, Los Angeles, CA, U.S. Air Force



Seeking the Light Gravity Without the Influence of Gravity

All living things sense gravity like humans might sense light or sound. The Biological Research In Canisters (BRIC-14) experiment, explores how moss cells sense and respond to gravity and light.

This experiment studies how gravity influences the internal structure of moss cells and seeks to understand the influences of the spaceflight environment on cell growth. This knowledge will help researchers understand the role of gravity in the evolution of cells and life on earth.

Plants respond to gravity (gravitropism) and light (phototropism). Typically, plant shoots will grow away from the direction of gravity and grow towards a light source. Some plants are primarily gravitropic while others are primarily phototropic. The moss, *Ceratodon*, is comprised of long chains of cells that grow from the filament tips. On earth, heavy particles in these tip cells fall toward gravity, causing the moss to grow away from the direction of gravity. When exposed to the microgravity environment of space, gravitropic forces no longer affect the moss. Due to decreased gravity, heavy particles don't fall out in the same manner. The resulting random particle distribution will cause changes in growth characteristics. Light direction is not altered in microgravity so the plant will still grow phototropically (towards light) just like on earth.

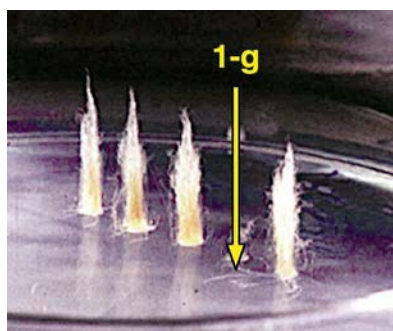

Moss Sample in Petri Dish.

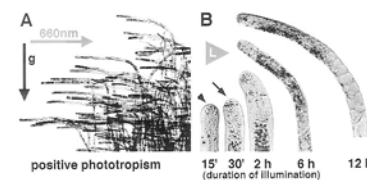

Effects of Phototropism

The knowledge gained during a previous shuttle flight, STS-87. Unexpectedly, moss specimens grown on STS-87 showed non-random subcellular component distribution and spiral growth.

For STS-107, the BRIC-14 experiment expands on the previous results with three major objectives.

1. Determine the age or developmental stage at which moss grows in a non-random pattern when exposed to microgravity conditions;
2. Determine the minimum illumination level required to impose a phototropic response on the growth pattern of the moss in the absence of gravity; and
3. Understand how microgravity affects the distribution of cell substructures.

The scientist's original hypothesis was that both random cell structure and cell growth would occur in space. The objectives for BRIC-14 experiment were developed from



Moss from STS-87, showing spiral growth patterns developed in the dark in microgravity.

Principal Investigator: Dr. Fred Sack, Ohio State University
Co-investigator: Dr. Volker Kern, Ames Research Center
Project Manager: Guy Etheridge, Kennedy Space Center
Project Engineer: Dave Reed, Kennedy Space Center

Background Information

To address the first objective of this flight experiment, selected moss colonies will be grown while exposed to a directional light for six days before launch. Once in space, the lights will be turned off and the moss will continue to grow in darkness. This moss will be compared to moss that is grown without any exposure to light but has had similar exposure time to microgravity. This part of the experiment will help determine the age and developmental growth stage of the moss at which non-random spiral growth is exhibited.

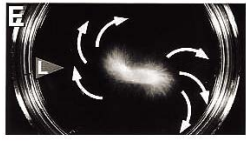

Non-random spiral growth after phototropically-induced directional growth (from STS-87).

The second objective of the experiment is to determine the illumination intensity required to induce a phototropic response in the absence of gravity. This part of the experiment will expose moss to three different levels of light and observe at which light intensity samples respond. The moss will grow in the dark for seven days in space prior to the lights turning on. This will allow the moss time to establish a random growth pattern prior to exposure to a directional light source.

The third objective is to understand how the non-random distribution of cell substructure takes place in space. Scientists have known for quite some time that fibers inside cells are responsible for the organization of subcellular components called organelles. An unexpected finding from STS-87 is that these heavy organelles, which are affected by gravity on earth, form non-random groups within

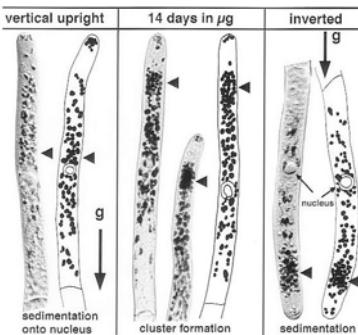

Cellular substructure distribution (from the STS-87 experiment).

the cells. The investigators hypothesize that this grouping is organized by these same fibers, although normally, the fibers don't cause grouping on earth. To test this theory, chemicals will be applied that breakdown the fibers. If the fibers play a role, then the organelles should become randomly distributed inside the cells during spaceflight. This experiment will provide information about how the positions of heavy organelles are controlled and organized inside cells on earth.

The astronauts will check the temperature and verify that the flight hardware is functioning each day. They will also switch the growth lights on and off at various locations in the flight hardware and will use a specialized tool to apply chemicals to the moss. These chemicals, called fixatives, will stop the growth process of the moss and preserve the specimens for analysis after the mission has ended.

Science Discipline Supported

This research primarily addresses Fundamental Space Biology, but can also be related to other disciplines.

Future Similar Experiments on *International Space Station*

Similar flight experiments can be conducted on the *International Space Station* to increase knowledge of how natural processes react to space and enrich life on Earth through people living and working in space.

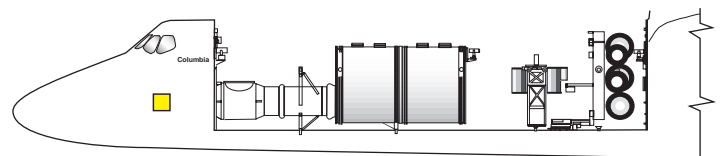

Approximate location of this payload aboard STS-107.

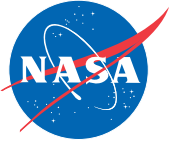

A Good Neighborhood for Cells Bioreactor Demonstration System (BDS-05)

Good neighborhoods help you grow. As with a city, the lives of a cell are governed by its neighborhood connections. Connections that do not work are implicated in a range of diseases. One of those connections — between prostate cancer and bone cells — will be studied on STS-107 using the Bioreactor Demonstration System (BDS-05).

Prostate cancer strikes about 200,000 men a year and is easily cured when diagnosed early, according to the American Cancer Society. Once it spreads to the skeleton it is inevitably fatal and kills more than 30,000 men a year. The public health cost is more than \$2 billion a year. To improve the prospects for finding novel therapies, and to identify biomarkers that predict disease progression, scientists need tissue models that behave the same as metastatic or spreading cancer.



Prostate cancer is a key health issue that eventually affects 1 in 6 American males. For African-American males, the disease and mortality rates are up to 50 percent and 200 percent higher, respectively, according to the National Prostate Cancer Coalition.

This is one of several NASA-sponsored lines of cell science research that use the microgravity environment of orbit in an attempt to grow lifelike tissue models for health research.

As cells replicate, they “self associate” to form a complex matrix of collagens, proteins, fibers, and other structures. This highly evolved microenvironment tells each cell who is next door, how it should grow and into what shapes, and how to respond to bacteria, wounds, and other stimuli.

Studying these mechanisms outside the body is difficult because cells do not easily self-associate

outside a natural environment. Most cell cultures produce thin, flat specimens that offer limited insight into how cells work together. Ironically, growing cell cultures in the microgravity of space produces cell assemblies that more closely resemble what is found in bodies on Earth.

NASA’s Bioreactor comprises a miniature life support system and a rotating vessel containing cell specimens in a nutrient medium. Orbital BDS experiments that cultured colon and prostate cancers have been highly promising. Long-duration experiments are planned for the *International Space Station* where multiple generations of cells can be grown.

Targeted health issues

- Therapies:** Musculoskeletal tissue disorders (in space and on Earth)
- Cancer models:** Prostate, breast, ovary, lung, and colon cancers
- Diabetes:** Pancreatic tissue for transplant
- Drug efficacy:** Non-animal/nonclinical testing of drug effects and toxicity

On STS-107, the BDS will grow a three-dimensional prostate culture model to support studies of the cellular interaction between the prostate and bone stromal (connective tissue) cells. The model will help scientists assess the effects of gene therapy on the growth of prostate cancer cell aggregates in research, clinical diagnoses, and treatments.

Standard cell culture in 1g Standard cell culture in mg

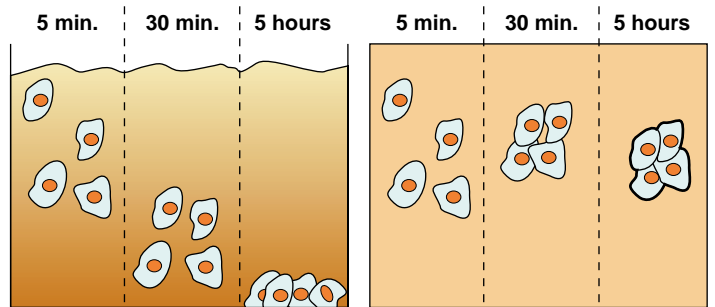

Cell constructs grown in a rotating bioreactor on Earth (left) eventually become too large to stay suspended in the nutrient media. In the microgravity of orbit, the cells stay suspended. Rotation then is needed for gentle stirring to replenish the media around the cells.

Principal Investigator: Dr. Leland W.K. Chung, Emory University, Atlanta, GA
Project Scientist and Project Manager: Thomas J. Goodwin, NASA Johnson Space Center, Houston, TX

Background Information

Science

A key factor in the growth of prostate cancer is the stimulation of tumor cells by the hormone testosterone. Understanding the factors that control the reproduction and spread of tumor cells will help researchers discover how to slow or stop the growth of a cancer. The BDS-05 experiment will culture human prostate cancer cells in microgravity so investigators can characterize the biochemical, molecular, and behavioral alterations of prostate cancer cells derived from reconstituted prostate organoids (RPCaO) grown under hormone-enriched or -deprived conditions. This will support studies of the “bystander” effects of toxic gene therapy on organoids. The ultimate goal is to develop a model for pre-clinical studies of drug and gene therapy, preparatory to the establishment of an effective clinical trial protocol.

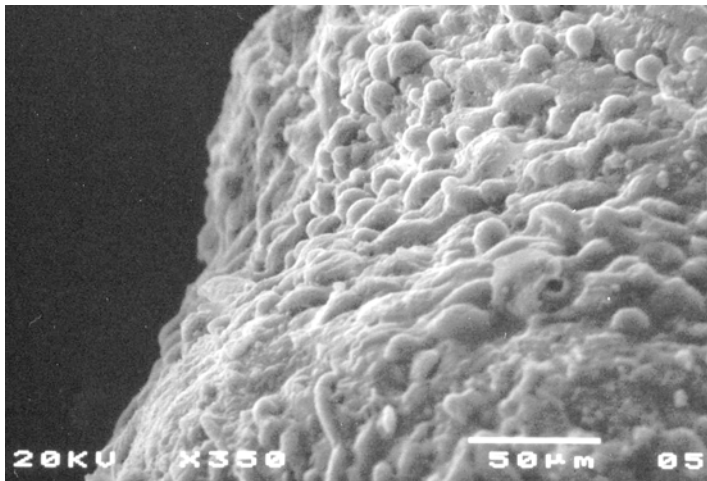

This prostate cancer construct was grown during NASA-sponsored bioreactor studies on Earth. Cells are attached to a biodegradable plastic lattice that gives them a head start in growth.

Flight Research Equipment

The heart of the BDS is a clear plastic rotating wall vessel, about the size of a soup can, containing the cell culture. A cylindrical filter down the center of the vessel rotates with the vessel and passes oxygen in and carbon dioxide out. Periodically, spent media are pumped into a waste bag and replaced by fresh media. The vessel rotates to provide gentle stirring of media without causing shear forces that would damage or kill the cells.

An Experiment Control Computer controls the Bioreactor, records conditions, and alerts the crew when problems occur. The crew operates the system through a laptop computer. The Biotechnology Specimen Temperature Controller holds cells until their turn in the Bioreactor, and a Biotechnology Refrigerator holds fixed tissue culture bags at 4 °C (39 °F) for return to Earth and analysis. A Gas Supply Module provides oxygen.

Research partners

National Institutes of Health: Center for Three Dimensional Tissue Culture, studying HIV-1 pathogenesis in tissue models, among other health issues.

Juvenile Diabetes Foundation: Studying the best route for cultivating and transplanting beta cells into Type 1 diabetics.

StelSys: Research in drug development and on a liver-assist device.

On STS-107, the crew will monitor the BDS, inject specimen cells, and periodically withdraw and fix cells and media samples for post-flight analyses. The crew also will exchange media bags as needed. At the end of the mission they will deactivate the system and fix all remaining cultures.

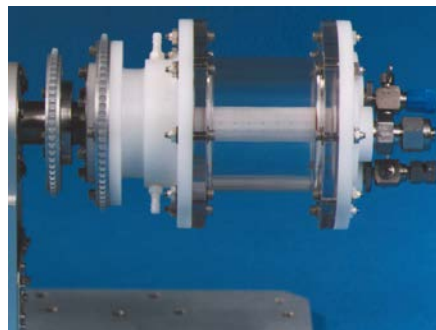

The major component of the Bioreactor Demonstration System is the transparent rotating wall vessel. It resides in a locker containing nutrient media bags and an oxygenator, plus associated plumbing to operate the system.

Previous Results

Experience aboard *Mir* has turned microgravity Bioreactor research into a mature science. In its first long-duration experiment, large cultures of bovine cartilage cells grew in the Bioreactor. The last NASA stay aboard *Mir* was crucial as it brought everything together in an effort to culture human tissue in the Bioreactor. Since then, the NASA Bioreactor team has been synthesizing these lessons into an advanced program being developed for the *International Space Station*.

The principal investigator’s team has conducted extensive ground-based experiments on prostate tumors in rotating-wall vessels and developed an extensive understanding of many of the chemical pathways and chromosomal changes involved in growing prostate cells. One set of results suggests that bone stromal cells can serve as “suicidal carriers” that deliver and express toxic genes that mediate tumor cell kills *in vivo*.

Commercial applications

In 1990, NASA granted Synthecon Inc. of Houston an exclusive commercial license to NASA patents for the bioreactor system. Since then, Synthecon has sold more than \$2 million worth of Rotary Cell Culture Systems™ and sponsored several related research agreements.

In 2000, NASA signed a Space Act Agreement with StelSys, a new venture formed by Fisk Ventures, Inc. and In Vitro Technologies, Inc. StelSys, based in Baltimore, will develop commercial medical products based on Bioreactor technology. They will focus on drug development and a liver-assist device for patients in need of transplant surgery.

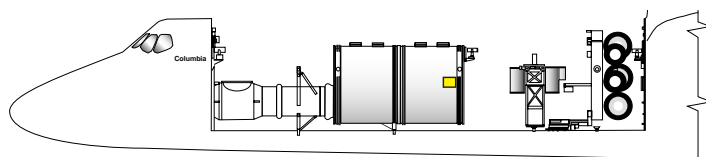

Approximate location of this payload aboard STS-107.

Photos. NASA.

FS-2002-06-068-MSFC

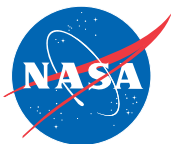

The Effect of Microgravity on the Smallest Space Travelers Bacterial Physiology and Virulence on Earth and in Microgravity

Since the first human flights outside of Earth's gravity, crew health and well-being have been major concerns. Exposure to microgravity during spaceflight is known to affect the human immune response, possibly making the crew members more vulnerable to infectious disease. In addition, biological experiments previously flown in space have shown that bacteria grow faster in microgravity than they do on Earth.

The ability of certain antibiotics to control bacterial infections may also differ greatly in microgravity. It is therefore critical to understand how spaceflight and microgravity affect bacterial virulence, which is their ability to cause disease. By utilizing spaceflight hardware provided by the European Space Agency (ESA), Dr. Barry Pyle and his team at Montana State University, Bozeman, will be performing an experiment to study the effects of microgravity on the virulence of a common soil and water bacterium, *Pseudomonas aeruginosa*. Importantly, these bacteria have been detected in the water supplies of previous Space Shuttle flights. The experiment will examine the effects of microgravity exposure on bacterial growth and on the bacterium's ability to form a toxin called *Exotoxin A*.

Another goal is to evaluate the effects of microgravity on the physiology of the bacteria by analyzing their ability to respire (produce energy), by studying the condition of the plasma membrane surrounding the cell, and by determining if specific enzymes remain active. Proteins produced by the bacteria will also be assayed to see if the normal functions of the bacteria are affected. In the context of human life support in spaceflight, the results of this experiment will

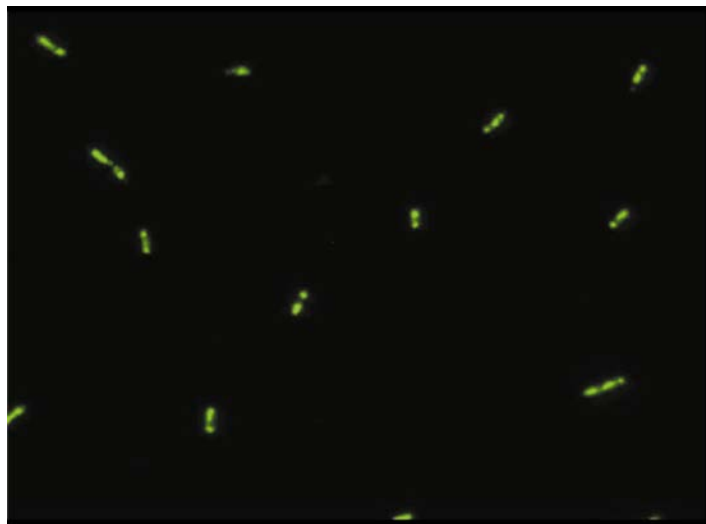

Bacterial respiration in response to microgravity is measured by providing cells with an indicator of respiratory enzyme activity, r-iodonitrotetrazolium violet (INT). Respiring cells take up INT and convert it to an insoluble form. Upon return to Earth, the cells are visualized via staining with the fluorescent molecule SYBR Green, and cells that were respiring on orbit (fluorescent cells containing black spots) are counted.

offer guidance in providing the highest possible water quality for the Shuttle in order to limit the risk of infection to human occupants and to minimize water system and spacecraft deterioration.

Earth Benefits and Applications

This experiment will provide valuable insight to the field of microbiology regarding the growth, physiology, and virulence of the common soil and water bacterium, *P. aeruginosa*, that is also able to cause disease in humans.

Principal Investigator: Dr. Barry Pyle, Montana State University, Bozeman, Montana

Project Scientist: Marilyn Vasques, NASA Ames Research Center, Mountain View, CA

Project Manager: Rudy Aquilina, NASA Ames Research Center, Mountain View, CA

Background Information

Science

Pathogenic species such as *P. aeruginosa* cause disease by producing toxins that affect the physiological functions of the host cells. Before launch, a strain of *P. aeruginosa* that produces Exotoxin A will be cultured in the laboratory under conditions that repress toxin production. Samples will be loaded into the cassettes and kept at +5 °C until they are activated on orbit to stimulate toxin production. The cassettes will be incubated for 24±1 hours at +37 °C, exposed to various treatments, and refrigerated at +5 °C until landing. Upon return to Earth, assays for exotoxin production, cell toxicity, proteins, and bacterial physiology will be performed.

Hardware

This experiment will be performed using ESA's Biopack spaceflight hardware which provides an incubator with centrifuges and a built-in cooler. On board the Space Shuttle, samples can be exposed to gravity levels ranging from microgravity to twice Earth's gravity. Biopack is designed to accommodate small biological samples, e.g. bacterial cultures, mammalian cell, tissue cultures and small plants or

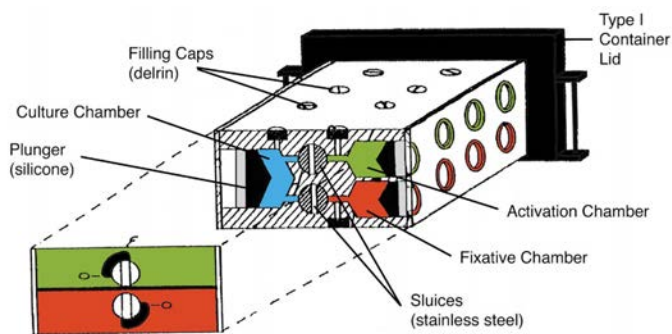

The experiment cassettes developed for the Biopack hardware contain the bacteria samples in culture chambers that will be activated in flight. Each Phorbol cassette contains six culture chambers (left side of cassette), six activation chambers (upper chambers, right side) and six fixative chambers (lower chambers). Pre-flight, cultures and solutions are loaded into their respective chambers. At the time of activation, the green/activation sluice is turned to the "open" position and the contents of the activation chambers is injected into the culture chambers using a plunger tool. The sluice is then closed and the cassettes are incubated. At the time of termination, a similar procedure is followed (red/termination sluice).

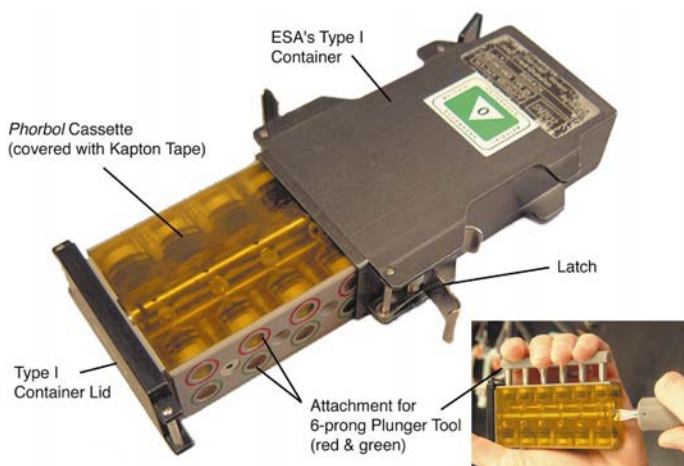

Science Discipline Supported

This experiment supports NASA's priorities for research aimed at understanding and alleviating problems that may limit astronauts' ability to survive and/or function during prolonged spaceflight, and will provide the field of microbiology valuable insight into the growth, physiology, and virulence of the common soil and water bacterium, *P. aeruginosa*.

insects. Dr. Pyle's experiment use the +37 °C incubator, while pre- and post-incubation refrigeration will be provided by a +5 °C Passive Thermal Conditioning Unit (PTCU).

The cultures will be housed in experiment cassettes that are contained in sealed containers. The experiment will utilize a total of 16 of these devices. Eight containers will comprise the flight set and eight containers will comprise the ground control set. On flight day 8, the astronaut crew will activate the cultures by pushing six activator plungers to transfer the bacteria into the growth medium. The containers will then be placed in the Biopack +37 °C incubator for 24 hours. For the flight experiment, four containers will be incubated in a stationary holder to expose the bacteria to the effects of microgravity, and four containers will be centrifuged for the on-orbit 1g control. Following incubation the crew will return the cassettes to refrigeration for the duration of the flight.

Previous Results

Preliminary data analysis from the NASA/ESA Biorack program (STS-81, Shuttle *Atlantis*, January 1997) suggests that the numbers of attached cells in biofilms grown in microgravity were several times greater than their Earth-based counterparts. The STS-107 experiment proposes to utilize this research opportunity to obtain further data on the effects of microgravity and spaceflight on the growth, physiology and virulence of waterborne bacteria. The results from this experiment will further our understanding of bacterial behavior in spaceflight and on Earth.

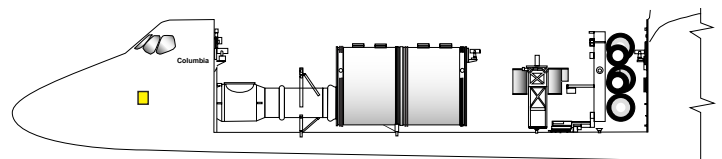

Approximate location of this payload aboard STS-107.

Picture credits. Pyle (page 1), Ames Research Center (page 2)

KSC-2002-057d



Understanding How Astronauts Adapt to Space and to Earth Anatomical Studies of Central Vestibular Adaptation

Significant changes take place in the nervous systems of astronauts during and following exposure to microgravity. These changes, particularly in the part of the brain that controls balance, the vestibular system, can cause sensations of rotation, dizziness, and vertigo, as well as space adaptation syndrome. Adaptation to the microgravity environment usually occurs within one week, and a subsequent re-adaptation period of several days is often required upon return to Earth. In order to realize long-term spaceflight, effective countermeasures for these symptoms must be developed.

The structural changes that take place in one of the vestibular regions of the brain (the cerebellar cortex) during the process of adaptation to Earth's gravity remain unclear and are the subject of an experiment being conducted on STS-107 by Dr. Gay Holstein of the Mount Sinai School of Medicine in New York. Using the rat as a model, Dr. Holstein and her team will seek to identify the cellular changes underlying the vestibular changes experienced by astronauts.

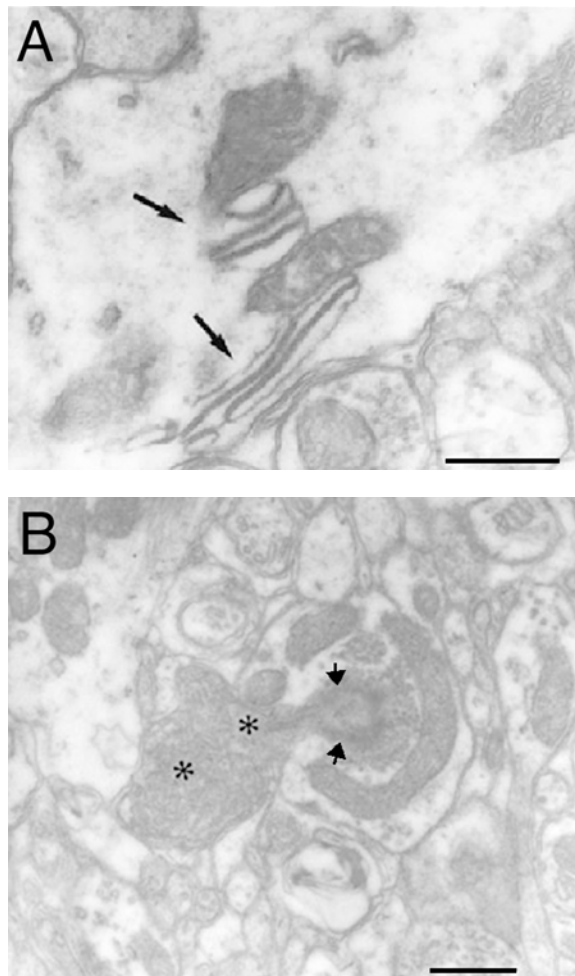

Electron micrographs of the cerebellar cortex from a rat after 24 hours of spaceflight. One unusual change observed in the ultrastructure of the Purkinje cells was the presence of extensive enlargements of the cisternal membranes into organelles called lamellar bodies (A, arrows). Panel B illustrates electron-dense degeneration in Purkinje cell dendrites (asterisks). Synaptic contacts with the degenerated cells are indicated by black arrows. The scale bar is 0.5 μm long. These observations will be further studied on STS-107.

Principal Investigator: Dr. Gay Holstein, Mount Sinai School of Medicine, New York, New York

Project Scientist: Marilyn Vasques, NASA Ames Research Center, Mountain View, CA

Project Manager: Rudy Aquilina, NASA Ames Research Center, Mountain View, CA

Background Information

Science

For this experiment, five flight and five ground control animals will be housed in two Animal Enclosure Modules (AEMs). The five flight animals will be flown aboard the Shuttle in one AEM, for a total of 16 days. Ground based 72-hour delayed control rats will be housed in the other AEM. Ultrastructural studies will then be carried out using electron microscopy. The results of this experiment will help to identify the cellular bases underlying the vestibular changes experienced by astronauts during periods of adaptation and re-adaptation to altered gravitational forces, and may provide insights for the development of effective pharmacotherapeutic countermeasures.

Science Discipline Supported

This experiment supports NASA's priorities for research aimed at understanding fundamental biological processes in which gravity is known to play a direct role and alleviating problems that may limit astronauts' ability to survive and/or function during prolonged spaceflight.

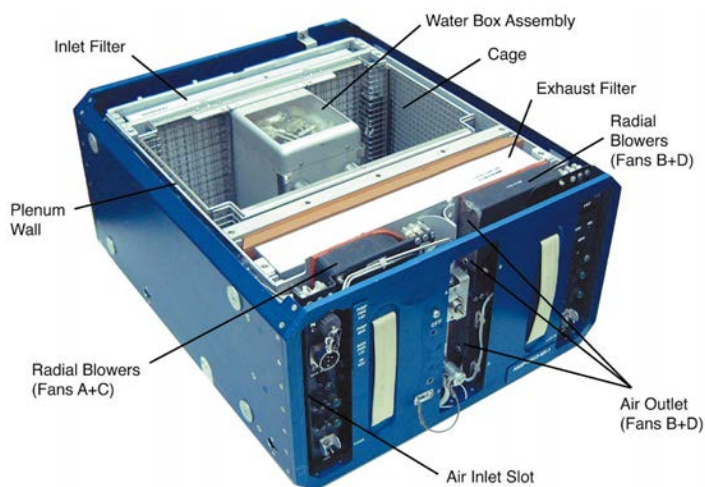

This experiment is part of the Fundamental Rodent Experiments Supporting Health (FRESH)-02 payload which consists of 13 rats housed in 3 AEMs. The animals, which will be shared among several different investigators, will experience microgravity for 16 days on board the Shuttle *Columbia*. The AEMs have been used successfully on many previous shuttle flights.

Hardware

The AEMs is a rodent habitat that provides ventilation, continuous filtered air flow to control waste and odor, timed lighting, food in the form of foodbars attached to the side of the cage, and a water supply which can be refilled as required. Rodents in the cage compartment of the AEM are not accessible but can be viewed through the clear lexan cover. This also allows for viewing of water level remaining in the AEM water box.

The AEM has been designed for minimum crew interaction and the animals adapt very well to this virtually self-contained system. The only nominal operations required are a daily hardware check, a daily visual animal health check, and periodic water refills.

Earth Benefits and Applications

The results of this experiment will help to identify the cellular bases underlying vestibular changes that occur during periods of adaptation and re-adaptation to different gravitational forces. In that light, the findings may provide insights for the development of effective pharmacotherapeutic countermeasures for vestibular changes during spaceflight. In addition, since the short- and long-term changes in neural structure and connectivity that occur during adaptation to microgravity mimic the neuronal alterations that occur in many progressive neurological disorders such as stroke and Parkinson's Disease, findings from this study using a rat model could offer guidance in the development of strategies for neurorehabilitation and treatment of these disorders.

Previous Results

The results from a previous experiment flown on STS-90 suggest that immediately following exposure to spaceflight, substantial structural reorganization takes place in the regions of the brain involved in controlling balance and equilibrium. Observations of brain tissue obtained after 24 hours of spaceflight indicate that several structural alterations occur in specific regions and cells of the rat brain. These alterations are not apparent in the cage control animals. The primary goal of the present project is to study these ultrastructural alterations in greater detail.

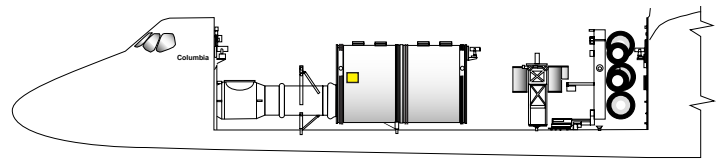

Approximate locations of this payload aboard STS-107.

Picture credits. Holstein (page 1), Ames Research Center (page 2).

KSC-2002-057c



Understanding How Space Travel Affects Blood Vessels Arterial Remodeling and Functional Adaptations Induced by Microgravity

Ever rise quickly from the couch to get something from the kitchen and suddenly feel dizzy? With a low heart rate and relaxed muscles, the cardiovascular system does not immediately provide the resistance necessary to keep enough blood going to your head. Gravity wins, at least for a short time, before your heart and blood vessels can respond to the sudden change in position and correct the situation.

Actually, the human cardiovascular system is quite well adapted to the constant gravitational force of the Earth. When standing, vessels in the legs constrict to prevent blood from collecting in the lower extremities. In the space environment, the usual head-to-foot blood pressure and tissue fluid gradients that exist during the upright posture on Earth are removed.

Earth Benefits and Applications

This experiment will contribute toward attaining a better understanding of how fundamental biological systems, such as the cardiovascular system, respond to the microgravity environment. The detailed study of the resulting vascular adaptations triggered by microgravity will yield essential information on the basic physiological responses of individual blood vessels involved in blood flow and pressure regulation. This information will also support the development of treatments or countermeasures to improve crew health and performance following their return to a gravitational environment.

The subsequent shift in fluids from the lower to the upper portions of the body triggers adaptations within the cardiovascular system to accommodate the new pressure and fluid gradients. In animal models that simulate microgravity, the vessels in the head become more robust while those in the lower limbs become thin and lax. Similar changes may also occur in

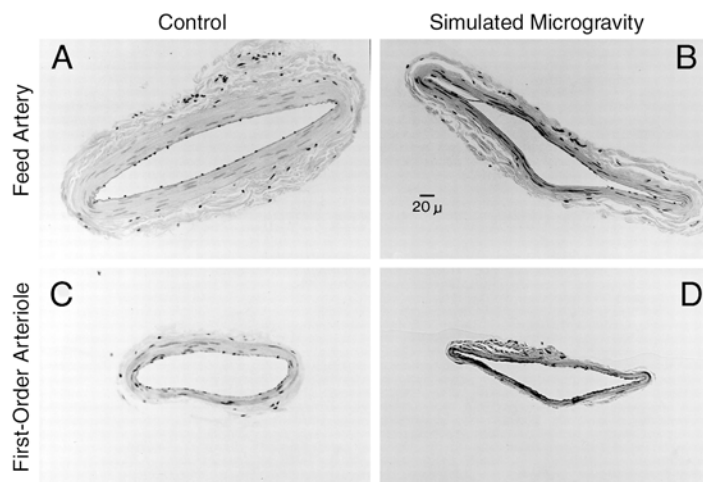

This figure shows feed arteries and first-order arterioles from control rats and from rats that have experienced simulated microgravity. After flight, the small blood vessels in hindlimb skeletal muscles that provide blood pressure resistance will be analyzed for their responses to chemical signals and pressure changes, and for changes in vessel structure and gene expression.

humans during spaceflight and while these adaptations are appropriate for a microgravity environment, they can cause problems when the astronauts return to Earth or perhaps another planet. Astronauts often develop *orthostatic intolerance* which means they become dizzy or faint when standing upright.

This dizziness can persist for a number of days making routine activities difficult. In an effort to understand the physiological details of these cardiovascular adaptations, Dr. Michael Delp at Texas A&M University, uses the rat as a model for his studies. For the experiment flown on STS-107, he will test the hypothesis that blood vessels in the rats' hindlimbs become thinner, weaker, and constrict less in response to pressure changes and to chemical signals when exposed to microgravity. In addition, he will test the hypothesis that arteries in the brain become thicker as a result of microgravity-induced fluid shifts toward the head.

Principal Investigator: Dr. Michael Delp, Texas A&M University, College Station, TX

Project Scientist: Marilyn Vasques, NASA Ames Research Center, Mountain View, CA

Project Manager: Rudy Aquilina, NASA Ames Research Center, Mountain View, CA

Background Information

Science

From previous studies using models that simulate microgravity, it is now evident that the shift of fluid toward the head and the unloading of postural muscles together alter the mechanical forces exerted on arteries, the vessels responsible for regulating blood flow and arterial blood pressure. The purpose of the present study is to determine whether the fluid shifts and muscle unloading that occur in actual microgravity, similarly alter rodent arterial vessel structure and function.

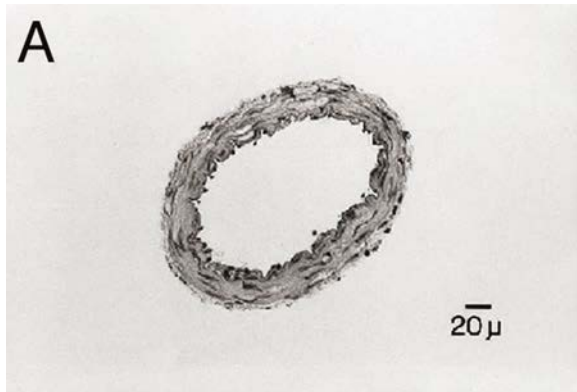

A cross section of the basilar artery from the brain of a control rat (A) and a rat that experienced simulated microgravity (B).

This experiment will address the effects of microgravity on vascular smooth muscle and vascular endothelial cell function and structure in resistance arteries and arterioles isolated from skeletal muscle and the brain. Three groups of rats will be studied. These will consist of 8 rats flown in microgravity, 8 rats from a ground-based vivarium cage control group, and 8 rats from a ground-based AEM control group. Resistance arteries or arterioles will be isolated and used for physiology experiments, in gene expression studies, and structural analyses. This work will provide potentially important information about the mechanisms underlying the orthostatic intolerance experienced by astronauts returning to Earth.

Science Discipline Supported

This experiment supports NASA's priorities for research aimed at understanding fundamental biological processes in which gravity is known to play a direct role and alleviating problems that may limit astronauts' ability to survive and/or function during prolonged spaceflight.

Hardware

The Animal Enclosure Module (AEM) is a rodent habitat that provides ventilation, continuous filtered air flow to control waste and odor, timed lighting, food in the form of foodbars attached to the side of the cage, and a water supply which can be refilled as required. Rodents in the cage compartment of the AEM are not accessible but can be viewed through the clear lexan cover. This also allows for viewing of water level remaining in the AEM water box.

The AEM has been designed for minimum crew interaction and the animals adapt very well to this virtually self-contained system. The only nominal operations required are a daily hardware check, a daily visual animal health check, and periodic water refills.

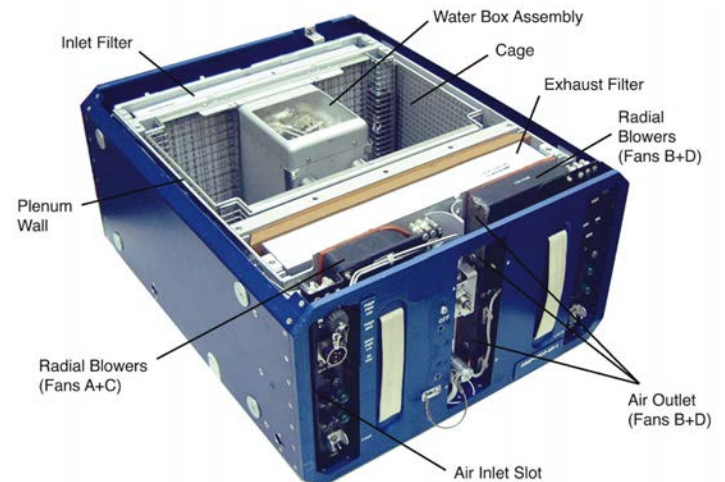

This experiment is part of the Fundamental Rodent Experiments Supporting Health (FRESH)-02 payload which consists of 13 rats housed in 3 AEMs. The animals, which will be shared among several different investigators, will experience microgravity for 16 days on board the Shuttle *Columbia*. The AEMs have been used successfully on many previous shuttle flights.

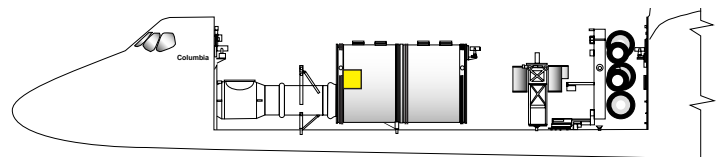

Approximate location of this payload aboard STS-107.

Picture credits. Delp (pages 1, 2), Ames Research Center (AEM).

KSC-2002-057a

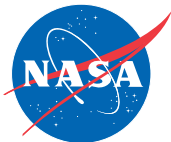

Understanding Fluid Shifts in the Brain

Choroidal Regulation Involved in the Cerebral Fluid Response to Altered Gravity

Fluid balance and regulation of body fluid production are critical aspects of life and survival on Earth. In space, without gravity exerting its usual downward pulling effect, the fluids of the human body shift in an unnatural, headward direction. After awhile, humans and other mammalian species adapt to the microgravity environment which leads to changes in the regulation and distribution of these body fluids. Previous spaceflight experiments have indicated that production of fluid in the brain and spinal cord, *cerebrospinal fluid (CSF)*, might be reduced in rats exposed to microgravity.

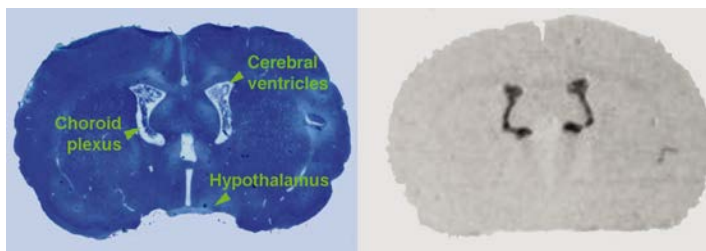

Dr. Gabrion will study the effects of microgravity on proteins responsible for water and ion transport in the brain and in other tissues. The choroid plexus which produces CSF is located in the cerebral ventricles (left). The right panel illustrates detection of aquaporin 1 messenger RNAs in the choroid plexus (black staining).

In this experiment conducted by Dr. Jacqueline Gabrion (University of Pierre and Marie Curie, France), proteins important for CSF production, and several molecules that regulate water and mineral transport, will be investigated in rats flown on the Shuttle. Dr. Gabrion and her team will determine the amounts of these proteins and molecules present in the brain in order to evaluate whether any changes have taken place during the rats' adaptation to microgravity. The levels of different aquaporins (proteins that act as a channel for water transport in and out of cells) will also be

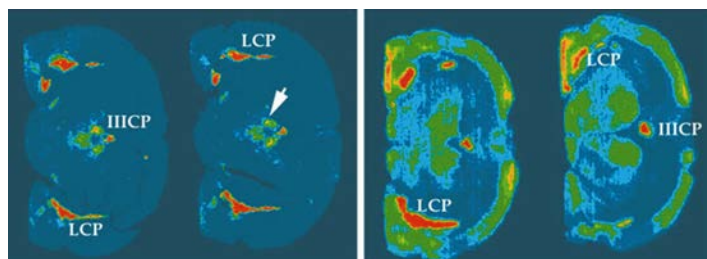

CSF production is influenced by the neurotransmitter serotonin. In frozen brain sections, serotonin receptor messenger RNAs in choroid plexus are shown in red (left). Serotonin receptors have also been detected in choroid plexus through their capability to specifically bind a serotonin-like probe (right, in red).

investigated in other areas of the brain and body to better understand the regulatory responses affecting these important water channel proteins.

In addition to producing essential and basic information about fluid production in the brain and body, this experiment will reveal fundamental information about the mechanisms involved in cerebral adaptation and fluid balance during spaceflight.

Earth Benefits and Applications

Because of its impact on fluid balance, spaceflight provides unique opportunities to investigate mechanisms of adaptation that involve fluid balance in the brain, kidneys and lungs. This experiment will contribute to a better understanding of basic mechanisms which regulate body fluid balance and homeostasis, and is important for the advancement of fundamental biology.

Principal Investigator: Dr. Jacqueline Gabrion, University of Pierre and Marie Curie, Paris, France
Project Scientist: Marilyn Vasques, NASA Ames Research Center
Project Manager: Rudy Aquilina, NASA Ames Research Center

Background Information

Science

Spaceflight is well known to induce headward fluid shifts and thus offers unique opportunities to analyze the role of gravity in body fluid distribution and fluid balance. However, the difficulties involved in measuring CSF volume and flow in these extreme experimental conditions, have prevented extensive study of CSF production and its transport processes during adaptation to altered gravity. To begin to understand CSF balance during adaptation to altered gravity, Dr. Gabrion and her team initiated studies over 10 years ago to determine the effects of spaceflight on choroidal structures and regulation in the rat.

Science Discipline Supported

This experiment supports NASA's priorities for research aimed at understanding fundamental biological processes in which gravity is known to play a direct role and alleviating problems that may limit astronauts' ability to survive and/or function during prolonged spaceflight.

This STS-107 experiment specifically focuses on 2 important families of transport proteins and on the biochemical signaling molecules that regulate CSF production. Biosynthesis of choroidal *Aquaporin 1* and *sodium-potassium (Na-K) dependent ATPase* will be studied using molecular staining techniques on fixed and/or frozen samples of choroid plexus. The expression levels of different aquaporins will also be investigated in other brain areas, the hypophysis, the kidney, and the lung.

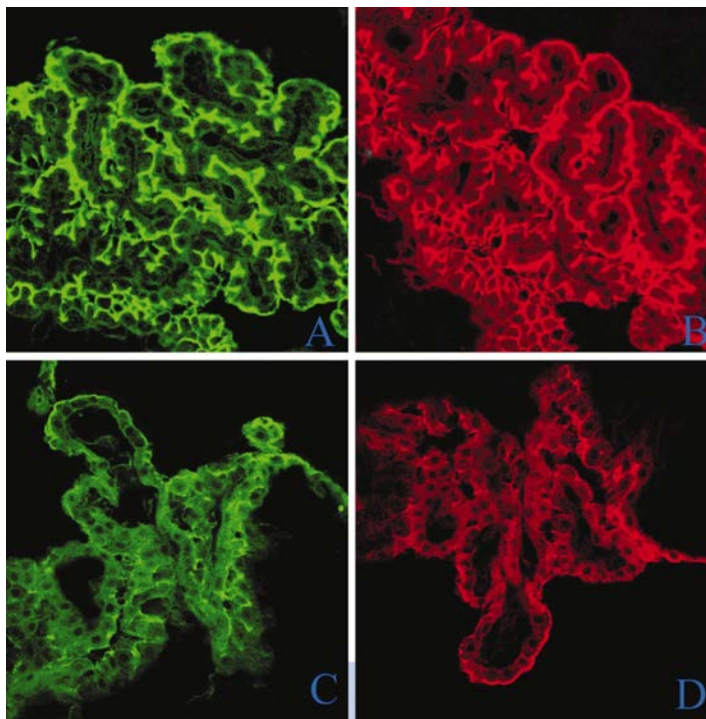

Immunodetection of aquaporin 1 (in green) and sodium-potassium ATPase (in red) at the apical pole of choroid plexus, (A, B) in a control rat and (C, D) in a ground-based model simulating some effects of spaceflight. A net decrease in both proteins was noted at the epithelial cells, suggesting that CSF production was decreased.

Previous flight experiments have demonstrated that reduced gravity dramatically alters the fine structure, functions, and maturation of the choroid plexus in the rat brain. Although no direct measurements of CSF secretion in microgravity have been performed to date, these findings indicate that adult rats likely experience a net reduction in CSF production during spaceflight. Such results might be generalized to humans and could partly explain headaches frequently endured by astronauts in space.

Hardware

The Animal Enclosure Module (AEM) is a rodent habitat that provides ventilation, continuous filtered air flow to control waste and odor, timed lighting, food in the form of foodbars attached to the side of the cage, and a water supply which can be refilled as required. Rodents in the cage compartment of the AEM are not accessible but can be viewed through the clear lexan cover. This also allows for viewing of water level remaining in the AEM water box.

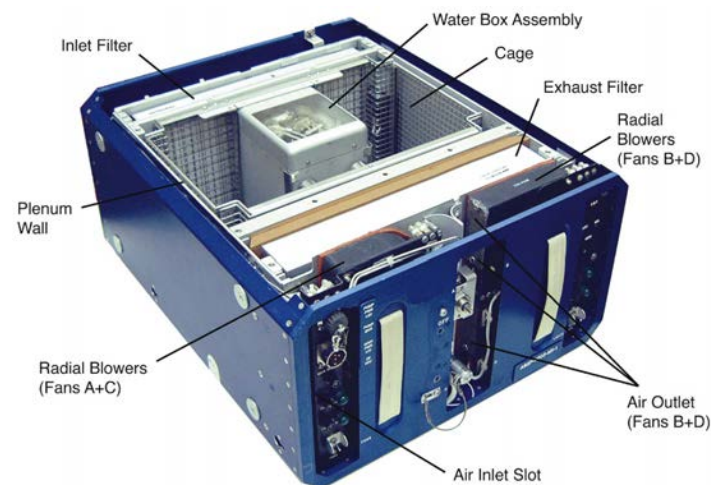

This experiment is part of the Fundamental Rodent Experiments Supporting Health (FRESH)-02 payload which consists of 13 rats housed in 3 Animal Enclosure Modules (AEMs). The animals, which will be shared among several different investigators, will experience microgravity for 16 days on board the Shuttle *Columbia*. The AEMs have been used successfully on many previous shuttle flights.

The AEM has been designed for minimum crew interaction and the animals adapt very well to this virtually self-contained system. The only nominal operations required are a daily hardware check, a daily visual animal health check, and periodic water refills.

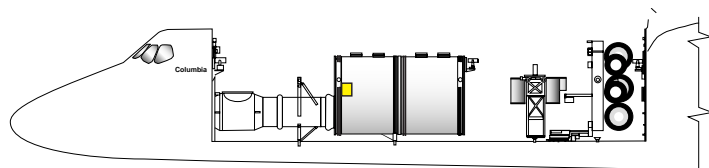

Approximate location of this payload aboard STS-107.

Picture credits. Gabrion (pages 1, 2), Ames Research Center (AEM).

KSC-2002-057b

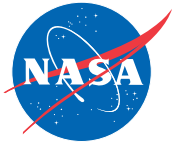

Space Magnets Attracting Interest on Earth

Applications of Physical and Biological Techniques In the Study of Gravisensing and Response System of Plants

The BioTube/Magnetic Field Apparatus (MFA) research is designed to provide insight into the organization and operation of the gravity sensing systems of plants and other small organisms. This experiment on STS-107 uses magnetic fields to manipulate sensory cells in plant roots, thus using magnetic fields as a tool to study gravity-related phenomena. The experiment will be located in the SPACEHAB module and is about the size of a household microwave oven.



Flax root growing in Magnetic Field Chamber hardware.

The goal of the experiment is to improve our understanding of the basic phenomenon of how plants respond to gravity. The BioTube/MFA experiment specifically examines how gravitational forces serve as a directional signal for growth in the low-gravity environment of space. As with all basic research, this study will contribute to an improved understanding of how plants grow and will have important implications for improving plant growth and productivity on Earth.

In BioTube/MFA, magnetic fields will be used to determine whether the distribution of subcellular starch grains, called amyloplasts, within plant cells predicts the direction in which roots will grow and curve in microgravity.

On Earth amyloplasts in plant cells accumulate in the direction of gravity causing a change in the cell. This essentially translates to a signal indicating which direction is “up” or “down”. The BioTube/MFA experiment utilizes high-gradient magnetic fields to change the distribution of

amyloplasts in flax roots. The magnetic field is concentrated at a specific point which produces magnetic gradient. As the root grows, it approaches the wedge and moves into the magnetic gradient. The starch grains are then repelled by the magnetic gradient, causing the roots to curve in the direction of the displaced starch grains.



BioTube/MFA in locker.

The BioTube/MFA experiment contains dry flax seeds (also known as *Linum usitatissimum*) that will germinate in space. The seeds will be watered and the roots will begin to grow across the high-gradient magnetic field wedges in two Magnetic Field Chambers. A third Magnetic Field Chamber will provide a uniform (non-gradient) magnetic field for the roots as a comparison to the high-gradient magnetic field. Time-lapse imagery will record pictures of the roots as they grow. Approximately 48 hours after seed watering, a chemical fixative will preserve the flax specimens for microscopic analysis and the experiment will end.

The science objectives of the BioTube/MFA experiment address three major questions:

1. Are amyloplasts the organelles in plant cells that perceive gravity?
2. Does the position or movement of the amyloplasts (sedimentation on earth, or, response to a high gradient magnetic field in orbit) affect the root growth direction?
3. Does gravity exert an effect on the deposition of cell wall material and the organization of plant cells organelles?

Principal Investigator: Dr. Karl H. Hasenstein, University of Louisiana at Lafayette

Project Manager: David Cox, Kennedy Space Center

Project Engineer: April Boody, Kennedy Space Center

Background Information

These goals will provide insight into the fundamental organization and operation of the gravity response system of plants and determine if, other than the root cap, other parts of the plant require cues for directional growth.

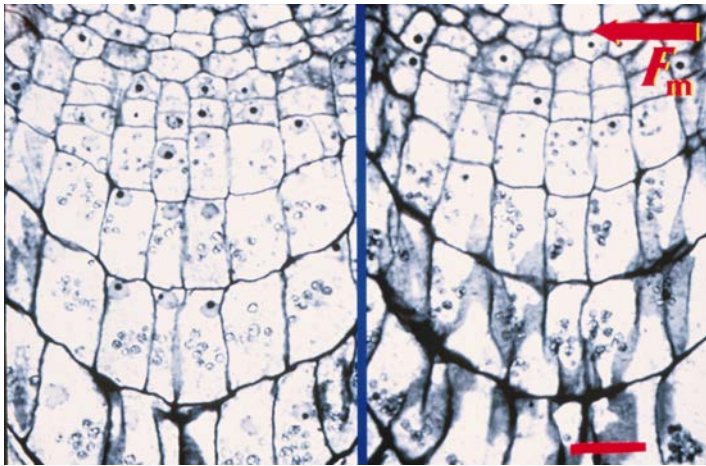

The left panel depicts the random orientation of amyloplasts in a simulated spaceflight experiment. The right panel shows the effect of a magnetic force displacing amyloplasts to the left.

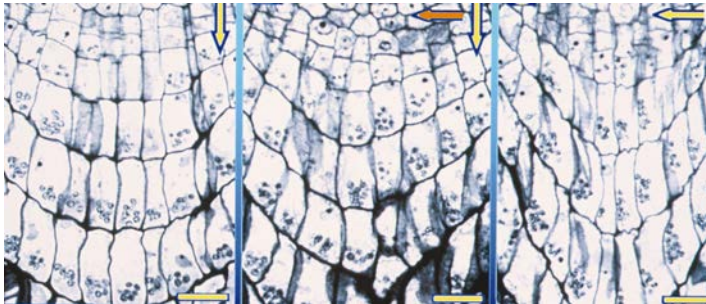

The left panel belongs to a normal root with the amyloplasts sedimented to the root cap region. The center panel shows a root cap with a lateral high-gradient magnetic field displacing amyloplasts to the left. The right panel shows a gravitationally affected root with amyloplasts sedimented to the left.

Astronauts will turn on the BioTube/MFA experiment three days prior to landing. All experiment operations will be complete within a 48 hour period. The BioTube/MFA software automatically controls a series of events that will deliver water to the seeds, take images of the growing roots and deliver a chemical fixative which preserves the roots for later analysis. The astronaut crew will periodically check on the equipment as the experiment progresses and will turn the power off following chemical fixation.

Science Discipline Supported

The BioTube/MFA research primarily addresses Fundamental Space Biology, but applies to other disciplines.

Future Similar Experiments on *International Space Station*

Similar flight experiments could be conducted on the *International Space Station* to increase the knowledge of how biological processes are affected by microgravity.

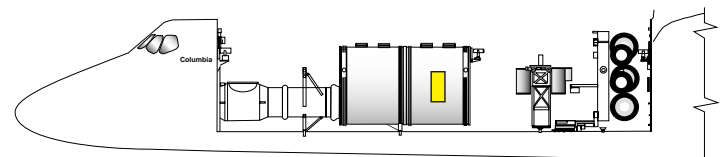

Approximate location of this payload aboard STS-107.

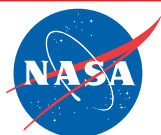

From Milk to Bones, Moving Calcium Through the Body Calcium Kinetics During Space Flight

Did you know that when astronauts are in space, their height increases about two inches? This happens because the weightlessness of space allows the spine, usually compressed in Earth's gravity, to expand. While this change is relatively harmless, other more serious things can happen with extended stays in weightlessness, notably bone loss. From previous experiments, scientists have observed that astronauts lose bone mass at a rate of about one percent per month during flight. Scientists know that bone is a dynamic tissue—continually being made and repaired by specialized bone cells throughout life. Certain cells produce new bone, while other cells are responsible for removing and replacing old bone. Research on the mechanisms of bone metabolism and the effects of space flight on its formation and repair are part of the exciting studies that will be performed during STS-107.



During STS-60, astronaut Drew Gaffney (center) draws blood from Millie Hughes-Fulford (left) while James Bagian looks on.

Calcium plays a central role because 1) it gives strength and structure to bone and 2) all types of cells require it to function normally. Ninety-nine percent of calcium in the body is stored in the skeleton. However, calcium may be released, or *resorbed*, from bone to provide for other tissues when you are not eating.

To better understand how and why weightlessness induces bone loss, astronauts will

participate in a study of calcium kinetics — that is, the movement of calcium through the body, including absorption from food, and its role in the formation and breakdown of bone. They will receive small amounts of special forms of calcium known as tracers. These allow scientists to trace the movement of calcium in the body. By tracking these tracers, we will see how calcium was processed and where it traveled in the body. Then, comparing the results from before, during, and after flight, we will learn how calcium metabolism changes when humans are in space.

- Earth Benefits and Applications**
- Examining the role of vitamin D in calcium metabolism
 - Understanding calcium kinetics
 - Investigating the formation and resorption of bone
 - Engineering healthy bone
 - Preventing osteoporosis and other bone diseases
 - Decreasing fractures.

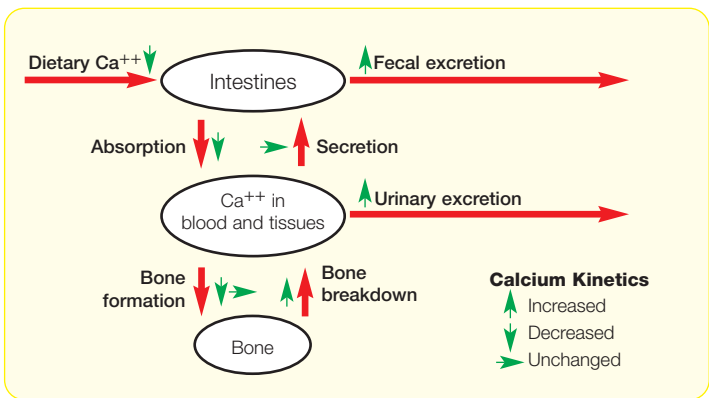

This diagram shows the normal pathways of calcium movement in the body and indicates changes (green arrows) seen during preliminary space flight experiments.

Principal Investigator: Dr. Scott Smith, NASA Johnson Space Center, Houston, TX
Project Scientist: Dr. Jacob Bloomberg, NASA Johnson Space Center, Houston, TX
Project Manager: Angie Lee, NASA Johnson Space Center, Houston, TX

Background Information

Science

Bones are living tissue, meaning that each day we build and break down bone. For this to occur we must provide adequate nutrition, including calcium, along with exercise. The preferred exercises are those that are weight bearing — walking, dancing, weight lifting, and other exercises that place weight on the legs. Astronauts exercise in space to try to keep their bones and muscles in shape. Despite this, bone loss still occurs, thereby providing an ideal laboratory to study the breakdown and rebuilding of bone and the path that calcium takes in reaching bone.



Dietary calcium is an important source of calcium for the body. The calcium is absorbed into your body from the food you eat and then stored in your bones.

Bone loss in microgravity has serious implications for bone health, including increased risk for bone fractures and kidney stones during flight and upon return to Earth. The bone loss experienced by astronauts in space is similar to the bone loss experienced by patients with osteoporosis or paralyzed individuals. To better understand calcium and bone changes during space flight, calcium kinetics and other aspects of bone and calcium metabolism will be measured. These measurements will be made before, during, and after flight. Information on the mechanisms of space-induced bone loss will be applicable to developing effective countermeasures for astronauts, and may help in developing treatments for osteoporosis or other bone-related diseases on Earth.

The calcium kinetics experiment will study how space flight affects calcium balance, calcium absorption, and bone resorption. This procedure requires that astronauts take two stable, non-radioactive forms of calcium (one orally and one intravenously). Samples of blood, urine, saliva, and feces (before and after flight only) will be collected and analyzed for the two calcium tracers. Using mathematical modeling techniques, scientists will determine the rates of calcium movement based on the tracer analyses. Specific parameters to be determined include the absorption of calcium from food, removal of calcium from the body, deposition of calcium in bone, and resorption of calcium out of bone.

Hormones, and other compounds which play a role in the control of bone and calcium metabolism, will also be measured to provide a more complete picture of the

mechanisms involved. This study will deepen our understanding of calcium movement through the body, the effects of weightlessness on regulation of bone and calcium, and the recovery of these systems after return to Earth.

Operations

The calcium tracers will be administered before, during, and after flight, with biological samples collected for up to 10 days after each tracer administration. Biochemical, hormone, and other endocrine markers of bone metabolism will be measured from blood and urine samples. Food intake during flight will be recorded to measure the amount of calcium entering the body. Mathematical modeling techniques (developed by the National Institutes of Health) will be utilized to integrate the data and determine the movement of calcium through the body. Specifically, these analyses will determine the rates of calcium absorption, the rates of calcium excretion in urine and feces, and the rates of bone calcium deposition and resorption.

Earlier Results

Calcium loss has been measured since the *Skylab* missions of the 1970s, which showed that calcium excretion increased compared to preflight levels. Biochemical markers of bone also indicated that bone resorption was greatly increased during the *Skylab* missions.

Calcium studies continued during the *Mir* missions of the 1990s. *Mir* crewmembers showed 1) decreased vitamin D, a vitamin/hormone that plays an important role in calcium balance; 2) unchanged or decreased levels of osteocalcin and bone alkaline phosphatase, markers of bone formation; and 3) increased excretion of products from the breakdown of collagen, a major structural protein of bone. Since sufficient subjects are needed to obtain meaningful data, this research continues calcium kinetics studies performed previously on NASA-*Mir* and Shuttle-*Mir* missions.

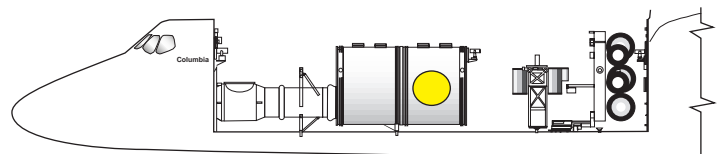

Approximate location of this payload aboard STS-107.

FS-2002-03-051-JSC

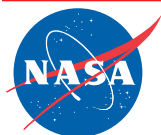

Letting Our Cells Do the Fighting Flight-Induced Changes in the Immune Response

The organisms that make us ill, such as bacteria, viruses, and fungi, are like attacking armies. We now know a great deal more about this unseen world of microscopic invaders. Fortunately for us, the human immune system is ever vigilant against them.

Microorganisms such as bacteria, viruses, and fungi occupy almost every corner of the Earth, and even parts of the human body. Some organisms are beneficial to us, helping to produce milk, cheese or yogurt. Others are potentially harmful, yet we don't always develop illnesses from them; they are kept in check by the sentinels of our immune system. Our immune system is routinely challenged by these organisms every day. When the immune response is diminished, our ability to fight off these "bugs" is lowered. And that's when we become ill.

Space flight presents a challenge to the immune system. Scientists believe that the stressful conditions of space flight — launch into orbit, adapting to microgravity, heavy workloads, and isolation from family and friends, to name but a few — reduce the astronauts' immunity. This immune suppression makes them more susceptible to common illnesses from bacteria and to re-infections from latent viruses in the body. In addition, risk of spreading illness in the confined environment of the Space Shuttle is high. Understanding changes in immune function will help scientists develop ways to keep astronauts healthy in space. This knowledge can also benefit earthbound populations.

This experiment will give scientists insight into the immune system by comparing how certain cells of astronauts' innate immune system — the

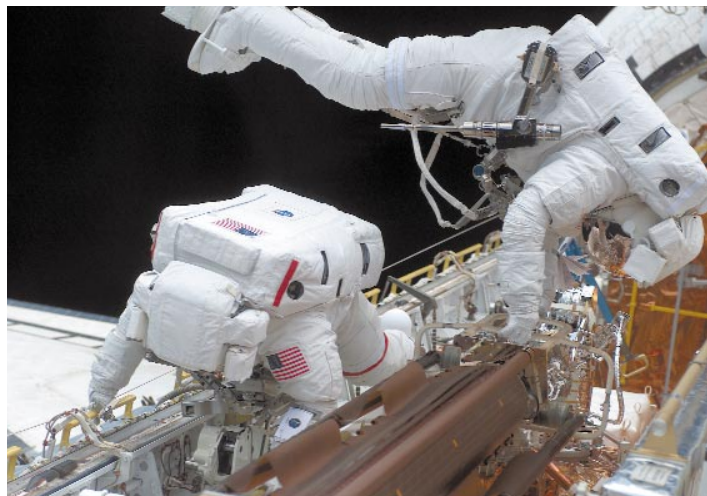

Astronauts John Grunsfeld (left) and Richard Linnehan participate in a space walk on STS-109 to work on the Hubble Space Telescope. Space walks can present significant physical and psychological stress on astronauts, possibly challenging their immune systems.

first line of defense against invaders — function after flight compared to before flight.

Earth Benefits and Applications

With greater understanding of the immune system in space, we can:

- Prevent impaired immunity for humans in confined conditions on Earth, such as polar stations, submarines, hospitals, and nursing homes
- Develop better vaccines
- Develop more precise treatments and drugs for illnesses
- Prevent emerging diseases.

Principal Investigator: Dr. Duane Pierson, Johnson Space Center, Houston, TX

Project Scientist: Dr. Jacob Bloomberg, Johnson Space Center, Houston, TX

Project Manager: Angie Lee, Johnson Space Center, Houston, TX

Background Information

Science

To minimize the health risk during flight, astronauts undergo preventive measures (such as immunization and physical exams) before flight. In order to understand the changes the immune system undergoes in microgravity and upon return to Earth, scientists must learn how immune cells behave before and after flight — measured as the response to invaders or the intensity of that response.

The body's immune system actually consists of two types of systems — the adaptive immune system and the innate immune system; they complement each other to provide effective protection. The adaptive arm responds to a foreign invader to destroy it and then retains a memory, an antibody against that specific invader should it ever attack again. This system is at work when you are vaccinated. Vaccination exposes you to a small, non-virulent dose of the foreign microorganism, which will not make you ill but allows your adaptive immune cells to respond and know what to look for in the future.

The innate arm of the immune system is the first line of defense, so its cells do not focus on specific invaders. In this way, it is non-specific and attacks cells recognized as foreign to eliminate them quickly. Innate cells destroy mainly through an action called phagocytosis, by which the foreign microorganism is engulfed and destroyed. They can also work with the adaptive immune system to destroy invaders.

The cells of interest in this experiment are three types of white blood cells of the innate immune system — specifically, neutrophils, monocytes, and a special set of lymphocytes called natural killer cells; all of these play important roles in warding off infection and illness. However, like any military force, these soldiers have different methods of attack.

Neutrophils, ready as the first line of defense, circulate in the bloodstream. They move out of the blood and into infected tissue to destroy infected cells. The results of their action can be seen in everyday life; for example, the pus from a boil is mostly a collection of dead neutrophils that have destroyed the microbial invaders.

Monocytes also circulate in the bloodstream. These cells are important not only for their defense in the bloodstream, but also because they mature and migrate into tissues where they become potent macrophages. These macrophages have the ability to engulf foreign antigens and destroy them with certain enzymes. Macrophages can also break down the microorganism into smaller pieces and present these to other immune cells for antibody production.

Natural killer (NK) cells are the last type of white blood cell to be studied. They belong to a subset of white blood cells known as lymphocytes. NK cells recognize foreign targets in a non-specific manner and destroy them. They play key roles in fighting tumor cells and cells infected with viruses or bacteria.

The data for this experiment will come from blood samples taken before and after flight. Three blood samples will be taken — 10 days before flight, on the day of return to Earth, and 23 days after return. The only restriction given to the astronauts is that they must record any medication taken. Once isolated from blood samples, these cells will be tested for any alteration in function.

Earlier Studies

Similar studies performed before and after shorter missions (lasting 5 to 11 days) have shown a decrease in the function of neutrophils and monocytes immediately before and after space flight when compared to non-astronauts.

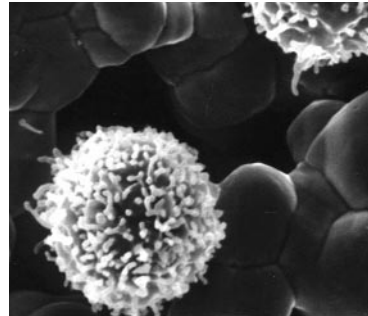

Immune cells in action: one kind of a human white blood cell, the lymphocyte, is shown here.

This suggests that astronauts are stressed before launch and after flight when returning back to Earth. These effects may also be dependent on mission length.

Previous studies performed on Apollo, *Skylab*, and Shuttle missions have studied the adaptive arm of the immune system. While NK cells were previously studied by Russian investigators, this is the first study to investigate the neutrophils and monocytes of the innate immune system.

This STS-107 study examines how the complex space flight environment affects the functions of immune cells before and after the mission. This contributes to our ever-maturing understanding of the immune system as it performs on Earth and in microgravity.

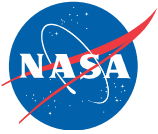

Maintaining the Body's Immune System Incidence of Latent Virus Shedding During Space Flight

Your body protects you from illness with its own security system — the immune system. This system keeps illness at bay not only by mounting a defense against foreign organisms, but also by controlling the population of bacteria and viruses that normally live in your body. But there's no need to panic: certain microbes can actually exist in your body without causing illness. Some bacteria are even beneficial—like the *E. coli* in the large intestine that are an important source of vitamin K.

While viruses are not exactly considered beneficial, they can also inhabit the human body without causing immediate harm or infection. A good example is the herpes simplex virus type 1 (HSV1), more commonly known as cold sores or fever blisters. This virus infects 70 to 80 percent of all adults but remains latent much of the time. While latent, the virus within cells remains dormant. Activation of the dormant virus causes it to make copies of itself (known as replication) constantly—detectable in body fluids such as urine or saliva in a process called shedding. When a person becomes sick or stressed, however, this weakened condition allows the virus to



Astronaut Frank Culbertson, Jr., exercises on a treadmill on the *International Space Station*. Exercise is one way to counter the negative effects of space flight.

reactivate and multiply. These elevated levels may be enough to produce symptoms, but shedding can also occur without symptoms. This ability to shed without showing signs of infection, or asymptomatic shedding, is of great interest, as it increases the chances of infecting others.

The stresses associated with space flight — adapting to microgravity, isolation from family and friends, living and working in a confined space, sleep deprivation, and busy schedules, to name but a few — may weaken astronauts' immune systems, leaving them at greater risk of viral reactivation. Members of the STS-107 crew will participate in this experiment, Incidence of Latent Viral Shedding in Space Flight, to help scientists understand how reactivation works in space, and at what level replication reaches before symptoms begin to show. This study also promises more insight into the behavior of the larger virus family, herpesvirus, which will help us understand how to prevent infection in populations on Earth and reactivation in those already infected.

Earth Benefits and Applications

- Better understanding of latent virus shedding, which affects populations on Earth, will improve approaches for minimizing shedding and further infecting others
- This molecular approach may be a rapid and reliable tool for early detection of stress and diminished immunity
- This technology may provide clinically relevant data to help patients suffering from chronic and acute stress
- Viral monitoring may lead to early intervention that minimizes adverse health effects of acute and chronic stress.

Principal Investigator: Dr. Duane Pierson, Johnson Space Center, Houston, TX
Project Scientist: Dr. Jacob Bloomberg, Johnson Space Center, Houston, TX
Project Manager: Angie Lee, Johnson Space Center, Houston, TX

Background Information

Science

Roughly 80 million people in the United States are infected with the herpes virus, which is the leading infectious cause of blindness. While we do not fully understand how viruses establish latency and later become reactivated, we do know that a weakening of the immune system increases the incidence (how often people are affected) and duration (how long they are affected) of viral reactivation and shedding. The results of this study will help develop treatments for fighting viruses and for reducing the spread of latent viruses on Earth as well as in space.

Additionally, scientists will consider other questions: What are the levels for latent shedding, and how much does it differ between individuals? At what level of reactivation does the virus produce symptoms? Since astronauts rely on medical care from physicians on Earth, finding answers to these questions and minimizing health risks are critical for success.

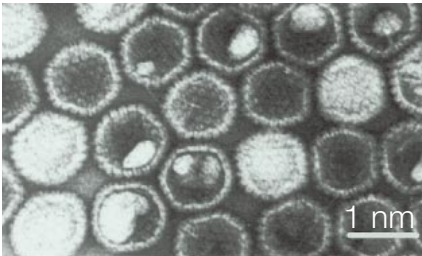

The varicella zoster virus, shown above, is the cause of shingles. This virus is a member of the herpesvirus group. Courtesy of Dr. Frank Fenner of the John Curtin School of Medical Research, and the International Committee on Taxonomy of Viruses Database (ICTVdb).

With this study, scientists will test their hypothesis that the incidence and duration of virus reactivation and shedding will increase in flight. Astronauts face any number of stresses before and during their mission, which can weaken their immune systems; scientists therefore expect to see a higher count of viruses during space flight as compared to before or after. In addition, scientists will compare the astronauts' data to data collected from a control group of people who remain on Earth to show whether the shedding in astronauts is different from the general earthbound population. Space flight may well be a major factor in viral reactivation and this study will help validate this hypothesis.

The viruses of interest in this investigation belong to the herpesvirus group, which is the most readily detectable of all latent viruses. The targeted strains are the herpes simplex virus types 1 and type 2, cytomegalovirus, varicella zoster virus, and Epstein-Barr virus.

The viruses of interest in this investigation belong to the herpesvirus group, which is the most readily detectable of all latent viruses. The targeted strains are the herpes simplex virus types 1 and type 2, cytomegalovirus, varicella zoster virus, and Epstein-Barr virus.

The viruses of interest in this investigation belong to the herpesvirus group, which is the most readily detectable of all latent viruses. The targeted strains are the herpes simplex virus types 1 and type 2, cytomegalovirus, varicella zoster virus, and Epstein-Barr virus.

Operations

For this study, astronauts give samples of saliva and urine, and blood—the body fluids into which viruses are shed—at various times before, during, and after flight according to the schedule shown in the following table.

Saliva and urine samples are analyzed for the presence of the four herpesviruses using an analytic process called the polymerase chain reaction (PCR), which allows the detection and counting of both symptomatic and asymptomatic virus shedding. To test blood samples, scientists use enzyme-linked immunosorbent assay. This test will reveal the levels of antibody generated against the four viruses,

indicating how active or weak the immune system is. Antibody levels before flight can be compared to levels after flight, showing how each astronaut's immune system changed. These results are also compared to those from the ground-based population, to determine if space flight and its stressors played a detectable role.

Earlier Results

Before Flight		In Flight		After Flight	
From 6 months to 5 months, every other day	50 days	10 days	Daily	Landing	14 days
saliva	blood urine	blood urine	saliva	blood urine saliva	saliva

Earlier studies from short-duration (Space Shuttle) and long-duration (Russian space station *Mir*) flights support the scientists' hypothesis of increased reactivation and shedding during space flight, in some cases increased by eight- to ten-fold. These results were also supported by findings from analogous environments on Earth, such as Antarctic winter excursions and closed-chamber studies. These data give an indication that space flight and analogous environments on Earth do indeed have some role in viral reactivation.

To yield accurate data, the astronauts must adhere to certain guidelines:

- No food or fluid for at least 15 minutes before saliva collection.
- All drug intake and stressful conditions should be logged.
- In the event of a cold sore, a sample swab should be taken for postflight analysis.
- Saliva collection should be taken at the same time during each mission day, after waking up and before brushing teeth.

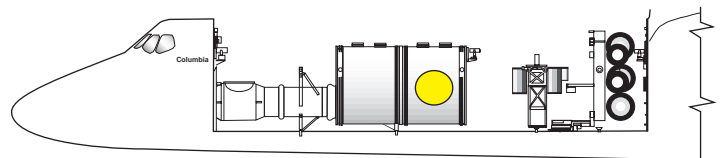

Approximate location of this payload aboard STS-107.



Musing over Microbes in Microgravity Microbial Physiology Flight Experiment

New York City, the most populated city in the United States, is home to over 8 million humans. This means over 26,000 people per square mile! Imagine, though, what the view would be if you peeked into the world of microscopic organisms. Scientists estimate that a gram of soil may contain up to 1 billion of these microbes, which is as much as the entire human population of China! Scientists also know that the world of microbes is incredibly diverse—possibly 10,000 different species in one gram of soil—more than all the different types of mammals in the world.

Microbes fill every niche in the world—from 20 miles below the Earth’s surface to 20 miles above, and at temperatures from less than -20°C to hotter than water’s boiling point. These organisms are ubiquitous because they can adapt quickly to changing environments, an effective strategy for survival.

Although we may not realize it, microbes impact every aspect of our lives. Bacteria and fungi help us break down the food in our bodies, and they help clean the air and water around us. They can also cause the dark, filmy buildup on the shower curtain as well as, more seriously, illness and disease. Since humans and microbes share space on Earth, we can benefit tremendously from a better understanding of the workings and physiology of the microbes. This insight can help prevent any harmful effects on humans, on Earth and in space, as well as reap the benefits they provide.

Space flight is a unique environment to study how microbes adapt to changing environmental conditions. To advance ground-based research in the field of microbiology, this STS-107 experiment



The astronauts and cosmonauts of STS-105 and Expeditions Two and Three gather for one of their first joint meals on the *International Space Station*. A better understanding of microbial physiology will help prevent illness for humans in the remote environment of space.

will investigate how microgravity affects bacteria and fungi. Of particular interest are the growth rates and how they respond to certain antimicrobial substances that will be tested; the same tests will be conducted on Earth at the same times. Comparing the results obtained in flight to those on Earth, we will be able to examine how microgravity induces physiological changes in the microbes.

Earth Benefits and Applications

Space-based research of microorganisms results in:

- Improved development of treatments for infectious diseases
- New knowledge on how microorganisms grow and develop with changing conditions.

Principal Investigator: Dr. Randolph Schweickart, ICOS Corp., Bothell, WA, and Dr. Michael McGinnis, University of Texas Medical Branch, Galveston, TX

Project Scientist: Dr. Jacob Bloomberg, Johnson Space Center, Houston, TX

Project Manager: Angie Lee, Johnson Space Center, Houston, TX

Background Information

Science

Microbiologists have long studied the physiology and metabolic pathways of microbes by manipulating environmental factors such as temperature, pH, and the content of the growth medium to see how their growth and function are affected. From this knowledge, we have developed antimicrobial agents and antibiotic treatments. This does not mean, however, that we have a complete knowledge of microbial physiology. Bacteria, for example, are constantly adapting and may develop resistance to antimicrobial agents. With the rise in the last few decades of antibiotic use and coincident resistance, the mechanisms for developing resistance are being studied intensely. We still have much to learn about microbial physiology and the genetic programming that allows for adaptation to changing conditions. Gravity plays a unique role in that it is one environmental condition in which all life forms have evolved. In these experiments, the absence of gravity will present the microbes with a challenge that they have not before encountered.

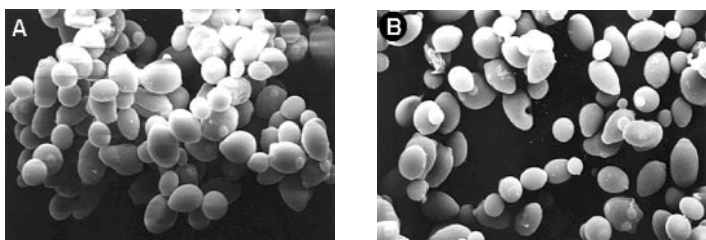

The scanning electron micrographs show *Saccharomyces cerevisiae* grown in microgravity (A) and gravity (B). In microgravity yeast cells grow in clusters. *S. cerevisiae* will be one of the fungal strains tested on STS-107 for changes in growth pattern and physiology.

The experiment consists of two separate microbial studies: one with bacteria (four species) and fungi (four species) as subjects, and the other with fungi alone (two species). Both studies follow the same procedures and use the same hardware. Their investigators are looking for the same data parameters — growth, use of components of the growth medium (different nitrogen and carbon sources), and reaction to antimicrobial agents — to show the effect of microgravity on the microorganisms. These studies will continue during a second phase in future flights to test the microbes against specific formulations of growth media and antimicrobials.

Hardware

These studies measure microbial growth during flight using a device called the automated microbial analysis system (AMS), a commercial instrument manufactured by bioMérieux Vitek, Inc., that has been adapted for space flight. Before flight, the bacterial and fungal strains to be tested are introduced, or inoculated, to cards containing the various growth media or antimicrobial agents being tested. These cards are refrigerated, sealed, and placed onto card trays to minimize the handling of the test cultures by crewmembers. This measure ensures the health of the crew as well as preserving the integrity of the experiment.

Once the cards containing the test strains have been

loaded into the AMS, its heater and circulation fan maintain constant incubator temperatures for microbial growth. The optical array of the AMS measures the optical density of each microbial sample, indicating the population and growth over time. A laptop computer serves as the interface between crewmembers and the AMS and also saves the data for analysis after flight.

Operations

The experiment will begin on the first day of flight with the setup and activation of the AMS. The six card trays for bacterial and fungal testing will be loaded into the AMS and tested in 24-hour incubation cycles for days one through six on orbit. The card trays for fungal testing alone will be loaded and tested in 48-hour incubation cycles for days seven through ten. To produce control data, identical procedures will be performed simultaneously on the ground with the same card populations. By comparing the data obtained in flight with those on Earth, researchers will be able to home in on the physiological response to microgravity.

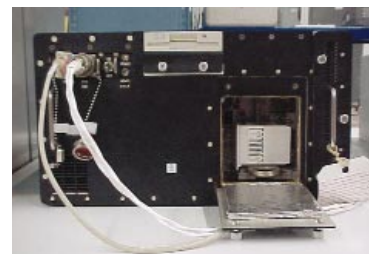

The cards containing the microbial test strains will be loaded into the AMS, shown above, during flight.

Earlier Results

Prior space flight research indicates that exposure to microgravity can lead to increased growth rates (Biosatellite in 1967) and increased resistance to antimicrobial agents (Salyut in 1982 and Spacelab D1 in 1985). However, there is limited data and conflicting results because experimental conditions are difficult to replicate. The STS-107 experiment uses a well-controlled methodology adapted for microbial research in flight to obtain conclusive results.

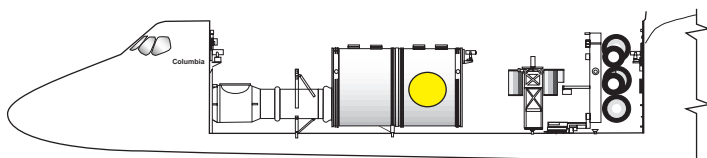

Approximate location of this payload aboard STS-107.



Building Muscles, Keeping Muscles Protein Turnover During Space Flight

As we age we lose muscle mass and strength. The problem is a matter of *use it or lose it* and more — a fact to which any active senior can attest. An imbalance in the natural cycle of protein turnover may be a contributing factor to decreased muscle mass. But the answer is not so simple, since aging is associated with changes in hormones, activity levels, nutrition, and often, disease.

The human body constantly uses amino acids to build muscle protein, which then breaks down and must be replaced. When protein turnover gets out of balance, so that more protein breaks down than the body can replace, the result is muscle loss. This is not just the bane of aging, however. Severely burned people may have difficulty building new muscle long after the burned skin has been repaired.

Answers to why we lose muscle mass and strength — and how doctors can fix it — may come from space. Astronauts usually eat a well-balanced diet and maintain an exercise routine to stay in top health. During long-duration flight, they exercise regularly to reduce the muscle loss that results from being in a near-weightless environment. Despite these precautions, astronauts lose muscle mass and strength during most missions. They quickly recover after returning to Earth — this is a temporary condition in an otherwise healthy population.

Members of the STS–107 crew are participating in a study of the effects of space flight, hormone levels, and stress on protein turnover. When we are under stress, the body responds with a change in hormone levels. Researchers hypothesize that this stress-induced change in hormones along with the near-weightlessness might result in the body synthesizing less muscle protein, causing



Mission Specialist Scott Parazynski takes a blood sample from U.S. Senator John Glenn, Jr., during STS–95. Senator Glenn and Mission Specialist Pedro Duque were the first to participate in the protein turnover study. Data collected during STS–107 will be added to that from STS–95.

muscles to lose their strength and size. Astronauts, who must perform numerous duties in a confined and unusual environment, experience some stress during their flight, making them excellent candidates for testing the researchers' hypothesis.

Earth Benefits and Applications

- Hormone models derived from missions mean better treatments for muscle atrophy on Earth.
- Hormone therapy may be more than a treatment for post-menopausal women; it may be the route to healthier muscles for the aging population, people with metabolic problems, and astronauts.

Principal Investigator: Dr. Arny Ferrando, University of Texas Medical Branch, Galveston, TX

Project Scientist: Dr. Jacob Bloomberg, Johnson Space Center, Houston, TX

Project Manager: Angie Lee, Johnson Space Center, Houston, TX

Background Information

Science

Muscle protein is always being created and broken down. If something disrupts this process, by decreasing the formation of new muscle, or speeding up the breakdown of existing muscle, we lose muscle. It usually is part of aging and can affect people with metabolic problems, but researchers believe it is treatable.

Testosterone increases lean body mass and promotes muscle development during puberty. As we age, testosterone levels normally decrease from youthful levels. Stress and lack of physical activity may also cause a reduction in testosterone. Cortisol, a steroid produced by the adrenal glands increases as we age. Too much cortisol in the bloodstream can cause the muscles to lose much of their amino acid content. The muscle proteins lose these amino acids, which are used instead to make glucose in the liver. This may cause diabetes resulting from increased blood glucose levels, but also means an additional loss of muscle protein.



Loss of muscle can affect mobility and independence. A well-balanced diet and moderate exercise, combined with hormone therapy only if needed, may help the elderly and people with metabolic illnesses maintain and improve their strength.

During space flight, a decrease in testosterone and an increase in cortisol may be behind reduced muscle mass. Researchers will examine the effects of stress, hormonal levels, and protein turnover in astronauts. By studying the relationship between altered hormonal levels and changes in protein turnover caused by the stresses of space flight, researchers can apply this information toward preventing muscle loss in astronauts.

Operations

Two months before launch, researchers use dual-energy X-ray absorptiometry (DEXA), a low-dose X-ray technique, to determine each astronaut's lean body mass. Blood samples are taken over three days, starting 60 days before launch. Before breakfast, astronauts give their first sample, and then they are given an alanine capsule containing a tracer chemical. Alanine is an amino acid that transports nitrogen throughout the body. By measuring the alanine and tracer in the blood, researchers know how quickly the body is creating muscle. Twelve hours after the first capsule, astronauts take 3-methylhistidine capsule labeled with a tracer. Three-methylhistidine, an amino acid produced when muscle is broken down, is used to determine the rate of protein breakdown. Another blood sample is taken 10 minutes later.

The sampling process is conducted twice before launch, twice during flight, and twice more after landing. DEXA whole-body images are collected before and after flight. Astronauts log everything they eat, medications they take, and exercise they do. Women also note where they are in their menstrual cycle. Findings from STS-107 will be compared to data from similar tests on the ground.

Earlier Results

Studies focusing on healthy, active men suggest that muscle loss in older individuals may result from the body's inability to make muscle proteins. This may be a result of hormone imbalance, lack of physical activity, or poor nutrition. Furthermore, men over 60 with low testosterone levels who take supplements to maintain normal levels have increased muscle volume and improved strength within months of beginning treatment. Burn patients also experience better muscle development with testosterone treatment.

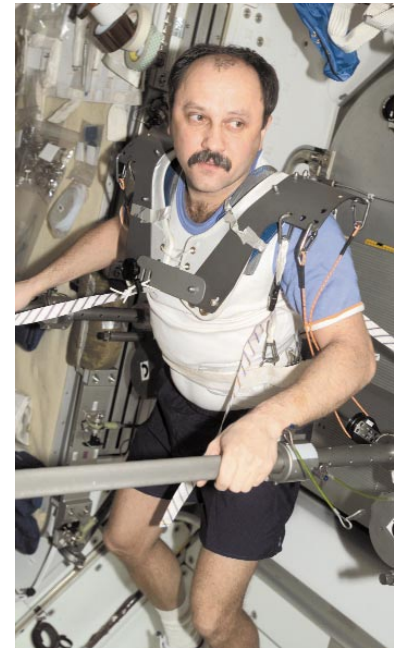

Yuri Usachev, Expedition Two crewmember, wears a harness while exercising aboard the *International Space Station*.

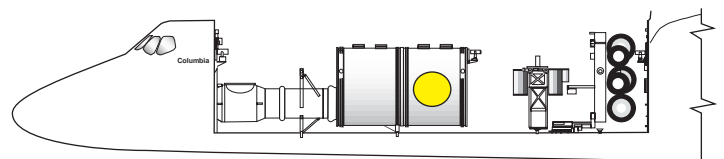

Approximate location of this payload aboard STS-107.



Protecting Space Travelers from Kidney Stones Renal Stone Risk During Space Flight

Renal stones, popularly known as kidney or bladder stones, are small rock-like objects formed in the kidneys or urinary tract by deposits of calcium and other minerals. The problem arises when the stones block the drainage of the kidney, resulting in urinary obstruction and pain. Passing these stones can be one of the most painful experiences a person will endure so doctors often prescribe pain relievers to ease the experience.

Drinking plenty of fluids, which help flush waste out of the body, and eating a well-balanced diet are the first steps to preventing stones. For individuals at risk, this may not be enough, and a doctor may recommend a special diet and medications. Unfortunately, approximately 60 percent of people who have had a renal stone will experience a recurrence. This is particularly true of men, who are four to five times more likely to develop stones than women. Renal stones do not discriminate based on age; even children are at risk.

Astronauts are particularly at risk of developing renal stones because they lose bone and muscle mass; calcium, other minerals, and protein normally used for bone and muscle end up in the bloodstream and then in the kidneys. Without plenty of fluid to wash them away, crystals can form and then grow into stones. This factor compounds the risk for astronauts, since they also perceive that they are less thirsty in space and will drink less than normal during the mission. To minimize all of these factors, doctors must instead treat the stone-forming compounds with medication. This study will use potassium citrate to reduce the risk of stone formation.



Drink plenty of water, Mr. Senator! U.S. Senator and astronaut John Glenn, Jr. takes a break with a beverage tube. Renal stones can usually be prevented by fluid intake, diet, and medication, but researchers are seeking more effective ways to prevent stone formation.

Renal stones are never convenient, but they are a particular concern for astronauts who have limited access to treatment during flight. Researchers are examining how earthbound preventions for renal stone formation work in flight, ensuring missions are not ended prematurely due to this medical condition. During STS-107, earthbound preventions and treatments become astronauts' gain.

Earth Benefits and Applications

- Examine the direct effect of potassium citrate on development of renal stones by determining changes in urine chemicals
- Use potassium citrate to prevent or reduce renal stone formation for patients who have continual problems with renal stones
- Lower the number of hospitalizations per year due to renal stones — 400,000 in the U.S.

Principal Investigator: Dr. Peggy Whitson, NASA Johnson Space Center, Houston, TX

Project Scientist: Dr. Jacob Bloomberg, NASA Johnson Space Center, Houston, TX

Project Manager: Angie Lee, NASA Johnson Space Center, Houston, TX

Background Information

Science

Waste proteins, chemicals, and minerals move from the bloodstream and are filtered out by the kidneys. Usually, if a person drinks enough water, this diluted waste is washed out as urine. However, painful renal stones occasionally form.

Changes in diet (in the United States, vegetarians are half as likely as meat-eaters to develop stones) and an increase in fluids can minimize stones, but for some, these precautions are not enough. A number of medical conditions, such as osteoporosis and hypercalcuria, also increase calcium and other minerals in urine and cannot be corrected with diet alone.

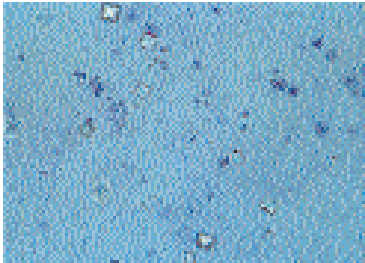

The micrograph shows calcium oxalate crystals in urine. These small crystals can develop to form renal stones.

Potassium citrate, used in the STS-107 study, is a common preventive treatment for renal stones. Citrate binds to calcium in the urine, preventing the calcium from crystallizing and developing into a stone. Citrate also makes the urine less acidic, reducing the risk of uric acid stones. By testing potassium citrate on astronauts, who have no medical conditions other than exposure to space to be at risk for stones, researchers examine the direct effect of the medication on excess minerals and the potential development of stones.

Citrate binds to calcium in the urine, preventing the calcium from crystallizing and developing into a stone. Citrate also makes the urine less acidic, reducing the risk of uric acid stones. By testing potassium citrate on astronauts, who have no medical conditions other than exposure to space to be at risk for stones, researchers examine the direct effect of the medication on excess minerals and the potential development of stones.

Operations

During STS-107, each crewmember receives a packet of pills. They take two pills at dinnertime, beginning three days before launch and ending 14 days after landing. The crewmembers also log everything they eat or drink, when they exercise, and what medication they take. They provide samples using urine collection kits.

After flight, researchers measure how much urine each crewmember voided during the mission and examine it for stone-forming chemicals, such as calcium and sodium. They also check the urine's pH, to see if the potassium citrate raised the pH to a less acidic value. The STS-107 data will be compared with results obtained from *International Space Station (ISS)* missions. Participation by the *ISS Expedition Three* crewmembers, who were in space for several months, helps researchers determine the effectiveness of potassium citrate over a longer period of time.

Hardware

Each urine collection kit comes with a urine collection device (UCD) designed for either men or women. Each UCD contains lithium chloride, which acts as a volume marker when it is filled. By measuring the amount of lithium in the urine sample, researchers determine how much urine the astronaut produced during flight. The astronaut uses a syringe to remove a small sample from the UCD. Both the UCD and the syringe sample are closed in a

leak-proof container and stored at room temperature until the end of the flight, when they are returned to a laboratory for careful analysis.

Earlier Results

While in space, astronauts have an increased risk of developing stones due to 1) the excess salts and minerals in their bodies, 2) the fact that they drink less fluids, and 3) the lower volume of urine produced. Earlier studies show that drinking extra fluid after flight, during the period when astronauts are readjusting to normal gravity, helps reduce the risk of renal stones. Drinking extra fluid in flight, however, simply washes the excess salts and minerals into the kidneys, increasing the astronauts' risk of developing stones. This makes medication, such as potassium citrate, the most promising way to stop stone formation.

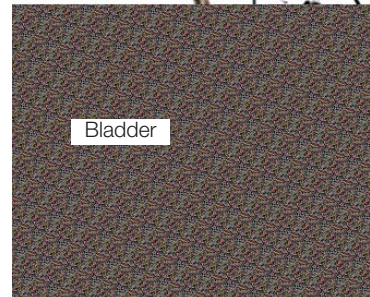
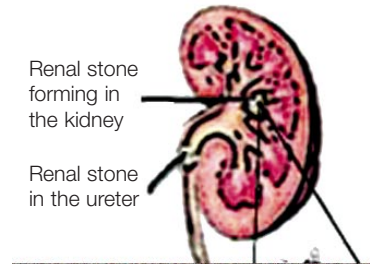

Stones can form in the kidney, ureter, and bladder. New treatments involving medication, ultrasound, or other non-invasive methods allow doctors to break up larger stones that cannot pass through the ureter.

On the ground, potassium citrate, combined with a carefully regulated diet, has shown promising results in reducing the risk of stone formation. For those with stones, taking potassium citrate can significantly reduce the recurrence of a renal stone.

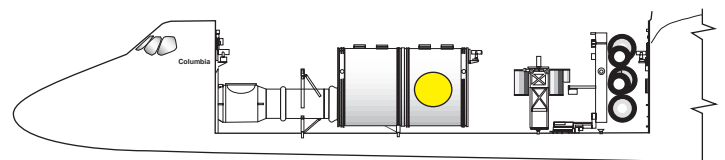

Approximate location of this payload aboard STS-107.

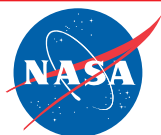

Astronauts Need Their Rest Too Sleep-Wake Actigraphy and Light Exposure During Space Flight

The success and effectiveness of human space flight depends on astronauts' ability to maintain a high level of cognitive performance and vigilance. This alert state ensures the proper operation of sophisticated instrumentation. An important way for humans to remedy fatigue and maintain alertness is to get plenty of rest. Astronauts, however, commonly experience difficulty sleeping while in space. During flight, they may also experience disruption of the body's circadian rhythm — the natural phases the body goes through every day as we oscillate between states of high activity during the waking day and recuperation, rest, and repair during nighttime sleep. Both of these factors are associated with impairment of alertness and performance, which could have important consequences during a mission in space.

The human body was designed to sleep at night and be alert and active during the day. We receive these cues from the time of day or amount of light, such as the rising or setting of the sun. However, in the environment of the Space Shuttle or the International Space Station where light levels are highly variable, the characteristics of a 24-hour light/dark cycle are not present to cue the astronauts' bodies about what time of the day it is. Astronauts orbiting Earth see a sunset and sunrise every 90 minutes, sending potentially disruptive signals to the area of the brain that regulates sleep.

On STS-107, researchers will measure sleep-wake activity with state-of-the-art technology to quantify how much sleep astronauts obtain in space. Because light is the most powerful time cue to the body's circadian system, individual light exposure patterns of the astronauts will also be monitored to determine if light exposure is associated with sleep disruption.



Scott Altman, mission commander for STS-109, sleeps on the flight deck of the Space Shuttle *Columbia*.

The results of this research could lead to the development of a new treatment for sleep disturbances, enabling crewmembers to avoid the decrements in alertness and performance due to sleep deprivation. What we learn about sleep in space informs treatment for earthbound populations, such as the elderly and insomniacs, who experience frequent sleep disturbances or altered sleep patterns.

Earth Benefits and Applications

This research could benefit the health, productivity, and safety of certain earthbound populations with similar conditions:

- Insomniacs
- Shift workers
- The elderly
- Travelers with jetlag.

Principal Investigator: Dr. Charles Czeisler, Brigham and Women's Hospital, Harvard Medical School, Boston, MA

Project Scientist: Dr. Jacob Bloomberg, Johnson Space Center, Houston, TX

Project Manager: Angie Lee, Johnson Space Center, Houston, TX

Background Information

Science

Astronauts will wear a light-recording and activity-monitoring device called the Actilight watch for the duration of the mission. Data on sleep-wake activity and light exposure patterns obtained during flight will be compared with those measured for two weeks on Earth,



The sun rises over Earth in this photo taken during STS-101 (the rear of the Space Shuttle *Atlantis* is silhouetted in the foreground). The Shuttle environment has highly variable light levels, a factor possibly contributing to astronauts' sleeping difficulties.



Astronauts of STS-51 are caught during a sleep period in the Shuttle *Discovery's* middeck.

approximately 90 days prior to flight. This will allow researchers to compare how much the astronauts slept in space versus how much they sleep normally. Astronauts will also wear the Actilight watch for the 11 days immediately prior to launch to determine if astronauts sleep less prior to flight. Recovery from space flight will also be assessed for one week following landing.

Each astronaut will also fill out a sleep log each morning. The logs are their subjective evaluation of the amount and quality of sleep. If an astronaut reports that his or her sleep was disturbed, questions

in the log address the cause of the disturbance. The astronauts will also report how much caffeine they consumed or if they took medication, as both could impact sleep.

Hardware

The Actilight watch and a sleep log will be used for each astronaut in the study. The Actilight watch is a flight-approved version of the Actiwatch-L product, made by Mini-Mitter, Inc. This device resembles a small wristwatch and measures the wearer's activity and exposure to ambient light. It is powered by a lithium manganese battery and can record data for about 30 days. The sleep log is a hard copy booklet.

Operations

The crewmembers will don their Actilight watches as soon as possible in flight, and simply wear them continuously on their non-dominant wrists outside of their sleeves. The watches can be removed temporarily for specific activities, such as a spacewalk. Upon landing they will turn in the watches for analysis. In addition, each crewmember will complete a sleep log every day, recording how long they slept and rating the quality of sleep and how alert they feel.

Baseline data will be collected before and after the flight using the same methods. Comparison of the data obtained in flight to baseline data will indicate to scientists the changes in astronauts' sleep-wake cycle and light exposure patterns.

Earlier Results

The results of previous research on both short- and long-duration space missions suggest that approximately

25 percent of crewmembers experience dramatic impairment of amount and/or quality of sleep. Hypnotic medications are the most frequently administered medications after the first several days in flight. This suggests that insomnia is a prevalent symptom among astronauts. Despite these data, little is known of the cause, prevalence, or severity of sleep disruption during short-duration missions and less is known about the effects on sleep during long-duration missions. Scientists hope that deeper understanding of sleep disturbances in space will lead to the development of treatments to help astronauts, as well as those who experience sleep disorders on Earth.

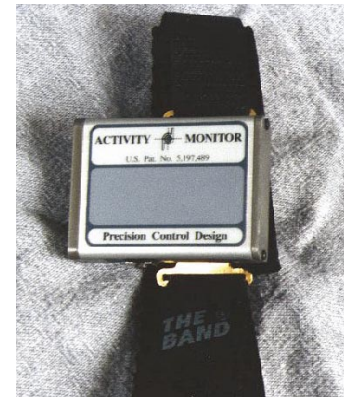

Shown is an actiwatch, similar to the model that STS-107 astronauts will don.

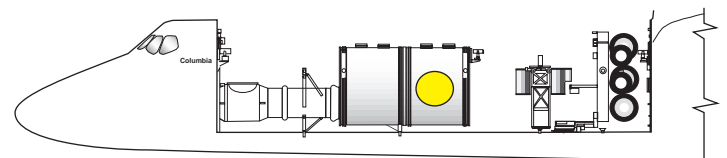

Approximate location of this payload aboard STS-107.



Deciphering the Role of Desert Dust in the Climate Puzzle The Mediterranean Israeli Dust Experiment (MEIDEX)

Numerous studies have shown that aerosol particles may be one of the primary agents that can offset the climate warming induced by the increase in the amount of atmospheric greenhouse gases. Desert aerosols are probably the most abundant and massive type of aerosol particles that are present in the atmosphere worldwide.

These aerosols are carried over large distances and have various global impacts. They interact with clouds, impact the efficiency of their rain production and change their optical properties. They constitute one of the primary sources of minerals for oceanic life and influence the health of coral reefs. They have direct effects on human health, especially by inducing breathing difficulties in children. It was lately discovered that desert particles carry pathogens from the Sahara desert over the Atlantic Ocean, a fact that may explain the migration of certain types of diseases.

Aerosols not only absorb solar radiation but also scatter it, so that their climatic effect is influenced not only by their physical properties and height distribution but also by the reflectivity of the underlying surface. This latter property changes greatly over land and is low over ocean surfaces.

Aerosol plumes are emitted from discrete, sporadic sources in the desert areas of the world and are transported worldwide by the atmosphere's wind systems. For example, Saharan dust reaches Mexico City, Florida, Ireland, Switzerland and the Mediterranean region, while Asian dust reaches Alaska, Hawaii and the continental United States. This means that in order to assess its global effects, one must observe dust from

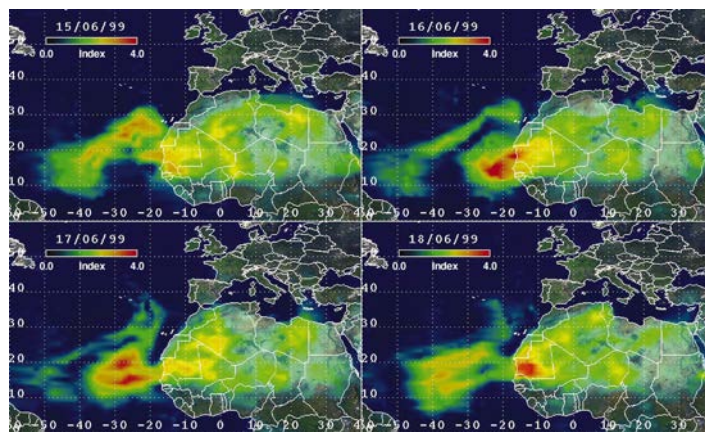

The long-range impact of the Saharan dry season can be seen in four days of images taken by the Total Ozone Mapping Spectrometer, June 15–18, 1999. The color scale shows the aerosol index from red (heaviest amounts of dust present) to green (the thinnest present). Under the darkest red the amount of ultraviolet sunlight is reduced to half its normal value, while under the green areas, UV sunlight is reduced by about 20 percent.

space. The Space Shuttle is a unique platform, because it flies over the major deserts of our planet, enabling measurements and remote sensing of the aerosols as they travel from source to sink regions. Such efforts must always be accompanied by in-situ data for validation and calibration, with direct sampling of the airborne particles. MEIDEX is a joint project of the Israel Space Agency (ISA) and NASA, under a cooperation agreement between the two agencies.

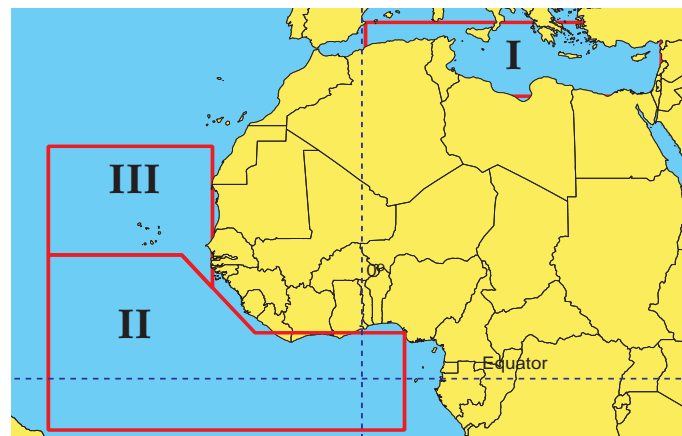

Three primary study areas for MEIDEX. The upper edge of Area I is the northern limit of *Columbia's* orbit.

Principal Investigators: Prof. Zev Levin and Prof. Joachim Joseph, Department of Geophysics and Planetary Sciences, Tel-Aviv University, Israel

Project Scientists: Prof. Yuri Mekler, Dr. Peter Israelevich, Dr. Eli Ganor, Tel-Aviv University, Israel

Participating NASA Scientists: Dr. Ernest Hilsenrath and Dr. Scott Janz, Goddard Space Flight Center, Greenbelt, MD

Payload Manager: Dr. Adam Devir, Tel-Aviv University, Israel; Maj. M. Moalem, Israeli Air Force

Project Coordinator: Dr. Yoav Yair, The Open University, Tel-Aviv, Israel

Background Information

Science

The primary mission of the Mediterranean Israeli Dust Experiment (MEIDEX) is to study the temporal and spatial distribution and physical properties of atmospheric desert aerosols over North Africa, the Mediterranean Sea and the adjacent Atlantic Ocean. This aim is achieved by a remote sensing experiment operated by the astronauts aboard the Space Shuttle. The second aim of the MEIDEX will be the inter-calibration of two primary current methods for the remote investigation of desert aerosols. Spectral channels of the MEIDEX radiometric camera combine in one multispectral camera, two wavelengths of the Total Ozone Mapping Spectrometer instrument in the ultraviolet band and four of the Moderate Resolution Imaging Spectroradiometer (on the Terra satellite) in the visible and near-infrared parts of the solar spectrum.

Secondary Observations

Sprites: The Xybion camera will be used for nighttime limb observations of Transient Luminous Events (sprites, jets and elves) associated with the electric discharges between thunderclouds and the lower ionosphere. The measurements of the optical emission will be correlated with ground based ELF/VLF electromagnetic measurements from several stations in Israel, the United States, and Antarctica.



Sprite observed by a University of Alaska, Fairbanks, research aircraft.

Slant Visibility: The astronauts will observe a set of surface targets that are located close to observation stations that monitor the optical properties of the atmosphere. The observations by the astronauts of the first view of a target and its subsequent disappearance along an orbit will enable, together with analysis of the accompanying data on the optical and meteorological properties of the neighboring atmosphere, the construction of an experimental model of slant visibility.

Sea-Surface Bi-Directional Reflection Function (BDRF): The BDRF is a crucial parameter in remote sensing and in any problem involving climate and weather. The properties of the ocean BDRF are still a subject of investigation. The sea surface albedo will be measured directly by instruments aboard the aircraft, and measured from space by the MEIDEX cameras when there are no clouds or dust in the area.

These remote measurements will be complemented by airborne in-situ measurements of aerosol properties such as size distributions and chemical composition as well as other atmospheric parameters. Research flights will be conducted daily by a team of scientists in an instrumented airplane based in Sicily, when the Shuttle passes over the Mediterranean Sea. The co-location and simultaneity of Shuttle, aircraft and ground-based correlated data will enable the validation of the remote space based observations. Forecast models will be used in order to predict the location and extent of dust clouds.

The output of the remote sensing experiment will be sequences of images of the target areas. In order to derive the desert aerosol properties from these images, the radiance from each pixel in an image will be analyzed. The problem



Dust collector mounted atop research aircraft.

of finding desert aerosol parameters will be the inversion of radiative transfer equations for a scattering and absorbing atmosphere above the surface with the given bi-directional reflection distribution functions (BDRF). Special computer models will be used to solve this problem.

Hardware

The payload consists of a radiometric camera (Xybion IMC-201) equipped with six narrow-band filters centered at 340 nm, 380 nm, 470 nm, 555 nm, 660 nm, and 860 nm. The Xybion camera has a field of view of $10.7 \times 14.0^\circ$, with a nadir footprint (looking straight down) of 52×68 km. It is boresighted with a second, wide (60°) field of view video camera that functions as a viewfinder. Both cameras are mounted on a special gimballed truss housed inside a pressurized Getaway Special canister with a coated quartz window. The truss can be tilted 22° to each side; this enables the crew to point the cameras to targets not directly below the Shuttle ground-track. Images from the cameras are recorded on three digital video recorders in the canister and inside the crew cabin. The MEIDEX canister is located on the aft side of FREESTAR in the payload bay.

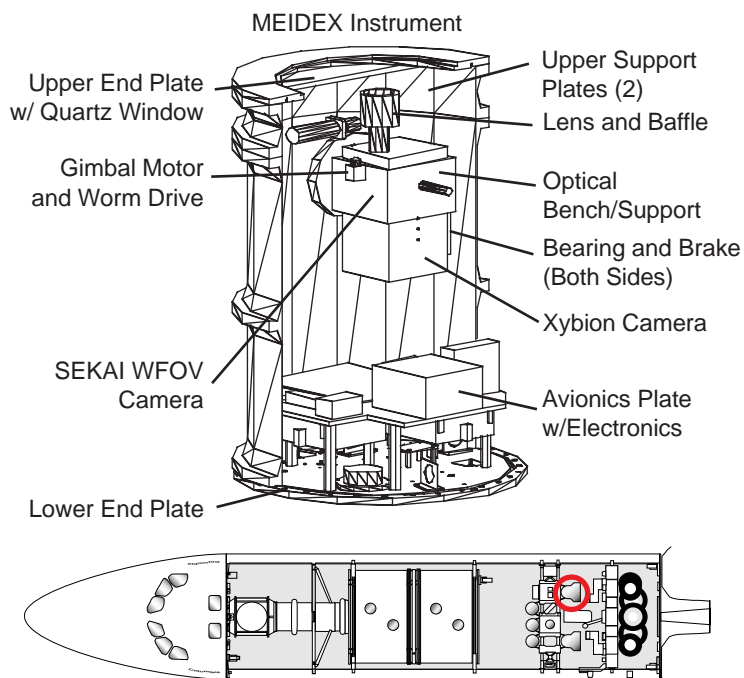

Approximate location of MEIDEX aboard STS-107.

NP-2002-5-289-HQ



Shuttle Ionospheric Modification with Pulsed Localized Exhaust (SIMPLEX)

SIMPLEX is a Department of Defense experiment that observes shuttle Orbital Maneuvering System engine burns. The orbiter OMS thruster firings are used to create ionospheric disturbances for observation by the SIMPLEX radars. There is no flight hardware associated with this payload.

The SIMPLEX radars are located at: 1) Arecibo, Puerto Rico, 2) Kwajalein, Marshall Islands, 3) Millstone Hill, Mass., 4) Jicamarca, Peru, and 5) the Very Large Array near Socorro, N.M.

The purpose of SIMPLEX is to determine the source of Very High Frequency (VHF) radar echoes caused by the Orbiter's OMS engines. On STS-107 a burn will be performed over the VLA.

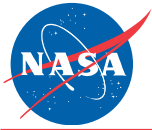

Looking at Ozone From a New Angle Shuttle Ozone Limb Sounding Experiment-2 (SOLSE-2)

The ozone layer above Earth is our planet's fragile sunscreen, protecting people, vegetation, and wildlife. NASA has been measuring ozone for more than 20 years by looking down, but SOLSE-2 will show that more information is available by looking at ozone from the side, at Earth's limb or atmospheric boundary.

When the ozone layer is compromised, increased ultraviolet (UV) levels from the sun cause health problems ranging from severe sunburns to skin cancer and cataracts. A concerted global effort has been made to reduce or eliminate the production of chemicals that deplete ozone, but the ozone layer is not expected to recover for many decades because these chemicals can remain active in the atmosphere for up to 100 years.

We know now that ozone monitoring needs to be focused in the lower stratosphere. The discovery of the ozone hole in 1985 demonstrated that very large changes in ozone were occurring in the lower stratosphere near 20 km, instead of the upper stratosphere as first expected, and where current ozone instruments are focused. Measuring ozone from a tangential perspective that is centered at the limb provides ozone profiles concentrated in the lower stratosphere.

The first flight of SOLSE proved that this technique achieves the accuracy and coverage of traditional measurements, and surpasses the altitude resolution and depth of retrieval of conventional techniques. Results from the first flight convinced the science community to design the next generation ozone monitoring satellite based on SOLSE. The Ozone Mapping and Profiling Suite (OMPS) is currently being built for the NPOESS satellite. The primary objective of SOLSE-2 is to confirm the promising results of

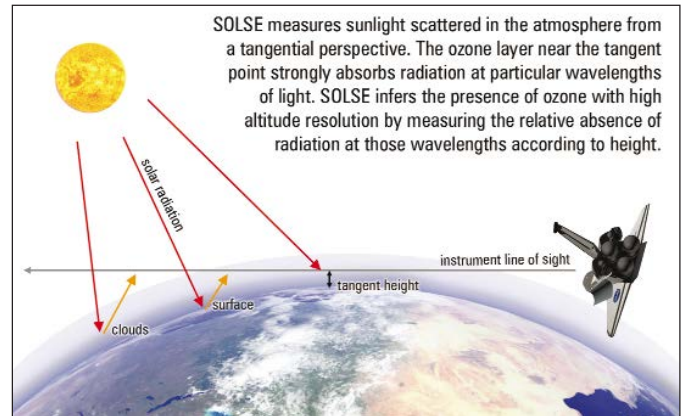

This illustration shows how ozone is seen using light scattered from the Earth's limb.

the first flight over a wider range of viewing conditions and spectral wavelengths.

Sometimes a really hard problem can be solved when you look at it from a different angle! While scientists conduct research, protect yourself by observing the UV index and spend less unprotected time outdoors.

Principal Investigators: Dr. Richard McPeters and Dr. Ernest Hilsenrath, NASA Goddard Space Flight Center, Greenbelt, MD
Project Scientist: Dr. Scott Janz, NASA Goddard Space Flight Center, Greenbelt, MD
Project Manager: Tammy Brown, NASA Goddard Space Flight Center, Greenbelt, MD

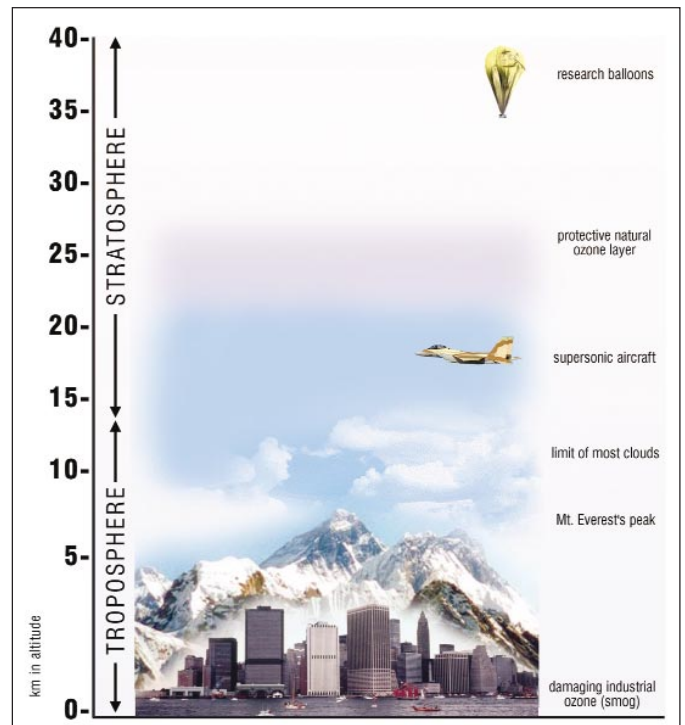

Background Information

Science

SOLSE demonstrates a conventional ozone measuring technique from a new perspective in order to focus on the stratosphere. The atmosphere scatters UV radiation from the sun back into space. When viewed from above, as current ozone monitoring instruments do, this is called "backscatter." Backscattered measurements cannot resolve ozone down to the lower stratosphere where ozone levels are changing the most. Limb scattered sunlight varies with altitude, so that SOLSE can distinguish the altitude distribution with high resolution into the lower stratosphere. Stratospheric ozone depletion is a global concern because the ozone layer there keeps 95 percent of the UV radiation from striking the Earth. High altitude resolution and global coverage are necessary to reduce the uncertainty of the ozone trends derived from the measurement. Limbscattered measurements will also increase the capability of atmospheric models to evaluate other factors in ozone depletion.

The Shuttle provides the perfect testbed to demonstrate new technology and measurement techniques without committing the funds for a flight instrument. Once proven over a wider range of viewing conditions, the SOLSE technique will be used to routinely measure ozone by the next generation weather satellites. NASA, NOAA, and the Department of Defense form the Integrated Program Office (IPO) that funds the SOLSE-2 demonstration as a risk reduction for OMPS.

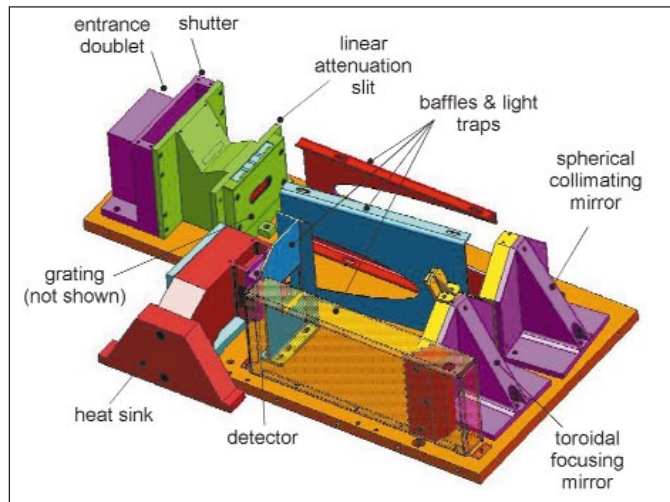
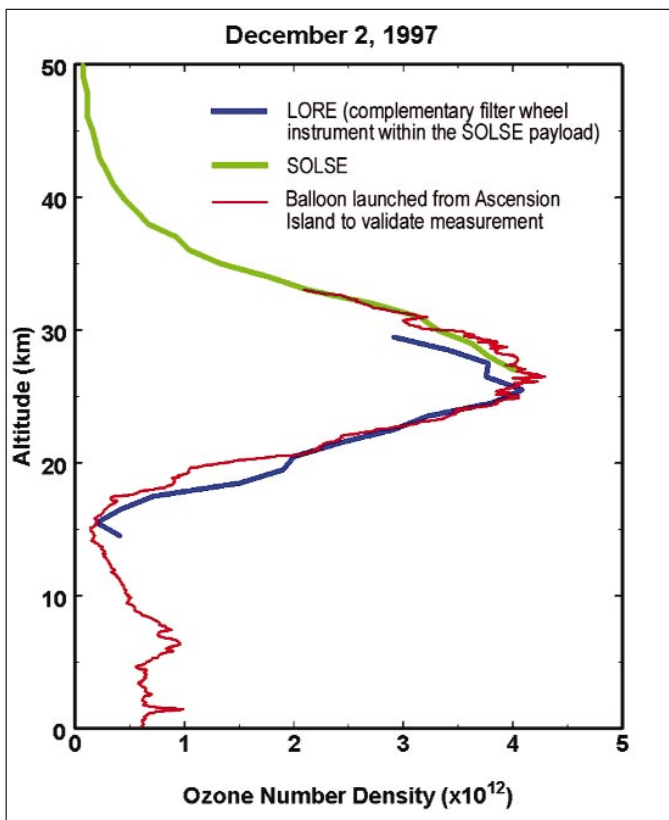

SOLSE instrument is a Czerny-Turner imaging spectrometer.

Hardware

SOLSE is an imaging spectrometer designed to produce high quality 2-dimensional images of the limb in visible and UV light while minimizing internal stray light. A holographic grating disperses the image of the limb into a spectrum that is focused onto a CCD array of 1024×1024 pixels. The back-thinned array is sensitive to UV and visible wavelengths. The optical slit is masked with a linear attenuation filter that normalizes the intensity of the limb that varies by a factor of 100 from top to bottom. A shutter controls the exposure of each frame. The Limb Ozone Retrieval Experiment (LORE) is a complementary filter wheel imaging photometer with a linear diode array detector. The filter wheel housing encloses 6 ion-assisted deposition filters at UV and visible wavelengths. Together, SOLSE and LORE retrievals span the atmosphere from 15 to 50 km above Earth's surface.

Previous Results

SOLSE and LORE provided the first retrieval of stratospheric ozone by limb scattering as a Shuttle payload on STS-87 in 1997. The results from the first flight demonstrated that limb sounding of ozone can achieve 1-3 km altitude resolution down to 15 km. The spectral coverage of SOLSE was changed for the reflight to include visible wavelengths in addition to UV to achieve LORE's depth of retrieval, which clearly detected the edge of the troposphere. The ground track of STS-107 is limited to 39° latitude north and south, but higher latitude coverage will be simulated with Shuttle maneuvers to observe the poles and seasonal patterns to verify the limb-viewing technique over wider viewing conditions.

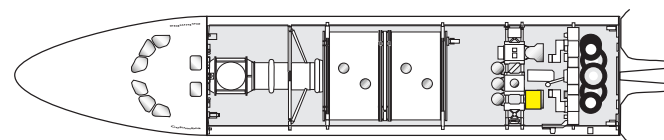

Approximate location of SOLSE payload aboard STS-107.

NP-2002-3-442-GSFC

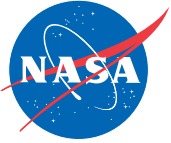

Measuring Solar Radiation Incident on Earth Solar Constant-3 (SOLCON-3)

Life on Earth is possible because the climate conditions on Earth are relatively mild. One element of the climate on Earth, the temperature, is determined by the heat exchanges between the Earth and its surroundings, outer space. The heat exchanges take place in the form of electromagnetic radiation. The Earth gains energy because it absorbs solar radiation, and it loses energy because it emits thermal infrared radiation to cold space.

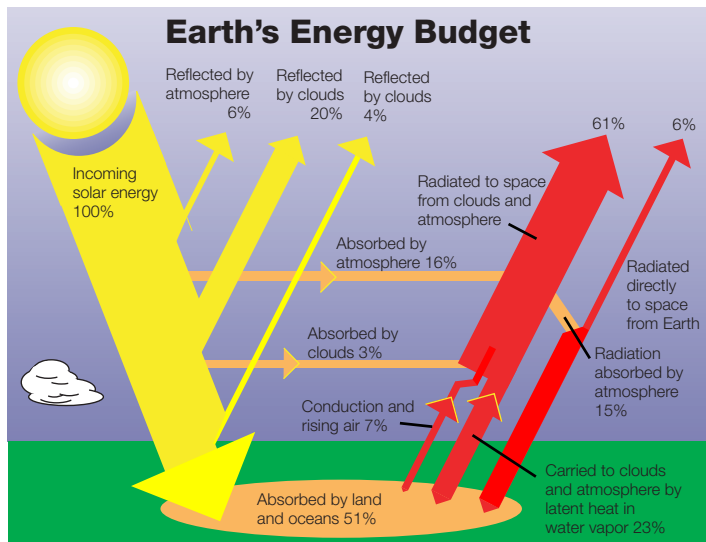

Earth gains energy through solar radiation and loses energy through thermal infrared radiation lost to space. The balance between energy gains and losses determines the temperature on Earth.

The heat exchanges are in balance: the heat gained by the Earth through solar radiation equals the heat lost through thermal radiation. When the balance is perturbed, a temperature change and hence a climate change of the Earth will occur.

One possible perturbation of the balance is the CO₂ greenhouse effect: when the amount of CO₂ in the atmosphere increases, this will reduce the loss

of thermal infrared radiation to cold space. Earth will gain more heat and hence the temperature will rise.

Another perturbation of the balance can occur through variation of the amount of energy emitted by the sun. When the sun emits more energy, this will directly cause a rise of temperature on Earth.

For a long time scientists believed that the energy emitted by the sun was constant. The "solar constant" is defined as the amount of solar energy received per unit surface at a distance of one astronomical unit (the average distance of Earth's orbit) from the sun. Accurate measurements of the variations of the solar constant have been made since 1978. From these we know that the solar constant varies approximately with the 11-year solar cycle observed in other solar phenomena, such as the occurrence of sunspots, dark spots that are sometimes visible on the solar surface. When a sunspot occurs on the sun, since the spot is dark, the radiation (light) emitted by the sun drops instantaneously. Oddly, periods of high solar activity, when a lot of sunspot numbers increase, correspond to periods when the average solar constant is high. This indicates that the background on which the sunspots occur becomes brighter during high solar activity.

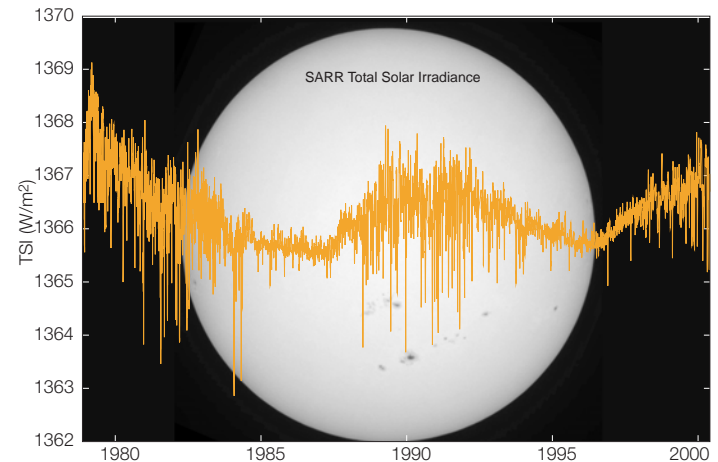

Variation of the solar constant with time since 1978. The variation has a period of approximately 11 years. The downward spikes correspond to the occurrence of dark sunspots which mark the height of the solar cycle. Some dark sunspots are visible on the background image of the sun.

Developer and Initiator: Dr. Dominique Crommelynck, Royal Meteorological Institute of Belgium, Brussels
Principal Investigator: Dr. Alexandre Joukoff, Royal Meteorological Institute of Belgium, Brussels
Project Scientist: Dr. Steven Dewitte, Royal Meteorological Institute of Belgium, Brussels
Project Manager: Andre Chevalier, Royal Meteorological Institute of Belgium, Brussels

<http://spaceresearch.nasa.gov>

Background Information

Science

To know the influence of the sun on climate changes on Earth, it is necessary to make long-term, accurate measurements of the solar constant. The most accurate measurements can be made from space, thus avoiding perturbations by Earth's atmosphere. A number of instruments to measure the solar constant have been flown since 1978 on satellites. Each of these satellite instruments has a limited lifetime. As the different instruments measure a different mean level of the solar constant, and as their measurements have to be combined into one single time series of the solar constant, a common reference, the Space Absolute Radiometric Reference (SARR), has been defined. It provides, for each individual instrument, a SARR adjustment coefficient to bring all the different instruments to the same mean level.

Why measure solar constant from orbit?

- SOLCON measures the solar irradiance from space to avoid perturbations by the atmosphere of the earth.
- SOLCON is used as a reference to construct a long duration time series of the solar irradiance.

The SOLCON instrument is a reference instrument for the measurement of the solar constant. It is flown regularly during short periods on the Space Shuttle. During shuttle flights SOLCON is used to determine the SARR adjustment coefficients of the satellite instruments that are active at the same time.

Instrument Principle

The SOLCON radiometer is the first differential absolute solar radiometer in space, developed at the Royal Meteorological Institute of Belgium. Basically solar radiation is measured through absorption in a cavity covered with black paint.

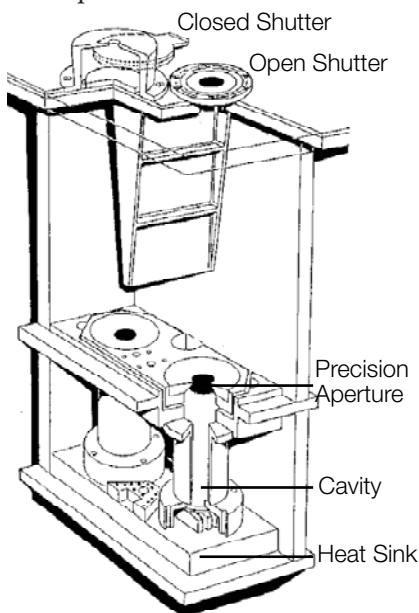

The central elements of SOLCON are a pair of blackened cavities on a common heatsink. Sunlight is absorbed in a cavity when the shutter in front is opened.

The SOLCON radiometer's core is formed by two blackened cavities constructed side by side on a common heat sink. In between each cavity and the heat sink a heat flux transducer is mounted. The difference between the two transducers' outputs gives a differential heat measurement. This measurement principle is analogous to a household pair of scales which give a differential measurement of weight.

Both cavity channels are equipped with a shutter in front to block or admit light to the cavity. In the open

shutter phase, solar radiation flows into the cavity through a precision aperture and is absorbed. Besides the heating of the cavity by the sun, the cavity can be heated electrically through a resistor.

Equilibrium between the two cavity heat fluxes is maintained by a regulating servo system. In the default measurement sequence a constant electrical power is fed into one cavity, the "reference" cavity, while its shutter remains closed. The electrical power in the other cavity, the "measurement" cavity, is regulated continuously, while its shutter sequentially opens and closes (both open and close phases take 90 seconds). When the instrument is pointed at the sun, the equilibrium electrical power in the measurement cavity drops proportionally to the absorbed solar power when going from the closed to the open phase.

Accurate electrical power measurements are obtained by separate measurement of the voltage over and the current through both cavity heating resistors. The basic measurement of the solar radiative flux is proportional to the drop in the measurement cavity electrical power divided by the precision aperture area.

Earlier Results

The SOLCON type instrument flew on the space shuttle on Spacelab 1 (1983), the Atmospheric Laboratory for Applications and Science missions — ATLAS 1 (1992), 2 (1993), and 3 (1994) — and on Hitchhiker missions as SOLCON-1 (1997) and -2 (1998). During this last mission, SOLCON was used to determine the SARR adjustment coefficients of the Variability of Solar Irradiance and Gravity Oscillations (VIRGO) radiometers on the Solar Oscillation and Heliospheric Observatory (SOHO) satellite, and to verify the SARR adjustment coefficients of the Active Cavity Radiometer Irradiance Monitor (ACRIM 2) and Earth Radiation Budget Satellite instruments. During its flight on Fast Reaction Experiments Enabling Science, Technology, Applications and Research (FREESTAR), SOLCON will be used to determine the SARR adjustment coefficient of the ACRIM 3 instrument, and to verify the stability of the SARR adjustment coefficients of the VIRGO radiometers on SOHO.

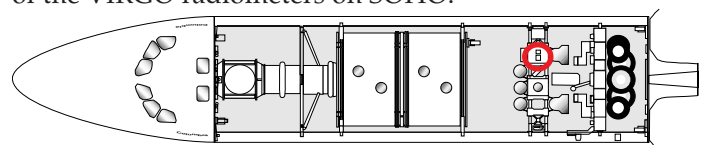

Approximate location of this payload aboard STS-107.



SOLCON-3 radiometer unit sitting atop FREESTAR. The digital processor unit is out of view to the right.

Photo credits. Royal Meteorological Institute of Belgium (graph page 1; page 2), NASA (drawing, page 1), Catania Astrophysical Laboratory (sun, page 1).

NP-2002-5-288-HQ

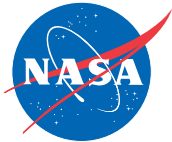

Studying Fires in Orbit Combustion Module-2 (CM-2)

Light a candle and it quickly forms the familiar teardrop shape caused by hot, spent air rising and cold, fresh air flowing in behind it to keep the fire going. But this airflow also obscures many of the fundamental processes that we need to understand if we are to fine tune the many ways we control combustion in manufacturing, transportation, heating, fire safety and pollution.

Conducting combustion experiments in the microgravity environment of orbit eliminates gravitational effects and slows many combustion processes so they become easier to study. Almost everything about fires changes in microgravity, and many differences are counter-intuitive:

- Microgravity fires may spread faster upwind than downwind, opposite to the behavior seen on Earth,
- While fire in space is often weaker than on Earth, flames in microgravity can be sustained under more extreme conditions than flames on Earth, and
- Turbulent flames, thought to be completely independent of gravitational influence, have doubled in size in microgravity conditions.

Professor Gerard Faeth at the University of Michigan has said that these findings show that gravity has impeded the rational development of combustion science much as the atmosphere has impeded astronomy.

To build on what we have learned from space about combustion, the STS-107 mission will re-fly the Combustion Module that flew on the Microgravity Sciences Laboratory 1 and 1R (STS-83 and -94) in 1997. Upgraded and designated CM-2, the module will accommodate three experiments,

Project Manager: Ann Over, NASA Glenn Research Center, Cleveland, OH

Deputy Project Manager: David Frate, NASA Glenn Research Center, Cleveland, OH

CM-2 Science Contact: Dr. David Urban, NASA Glenn Research Center, Cleveland, OH

CM-2 Experiments

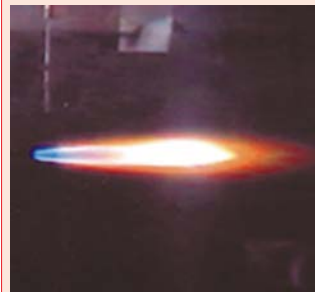

Laminar Soot Processes (LSP):

Evaluate and predict flame shape and internal structures; determine the nature of the soot emission process; validate new universal equations for soot and temperature in a flame; and investigate the soot-bursting hypothesis. Results will improve our understanding of turbulent flames found in many combustion devices on Earth.

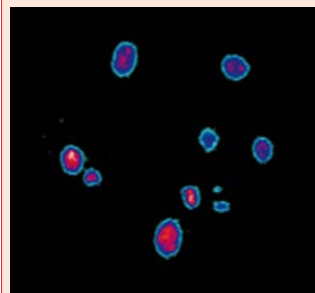

Structures of Flame Balls At Low Lewis-Number (SOFBALL-2):

Improve our understanding of the flame ball phenomenon and lean (low fuel) burning combustion; determine the conditions under which they can exist; test predictions of duration; and derive better data for critical model comparison. Results will lead to improvements in engine efficiency, reduced emissions, and fire safety.



Mist: Measure the effectiveness of fine water mists to extinguish a flame propagating inside a tube to gain a better understanding of the mist fire-suppression phenomenon. What is learned will help us design and build more effective mist fire-suppression systems for use on Earth, as well as in space.

Laminar Soot Processes (LSP-2), Structure of Flame Balls at Low Lewis-number (SOFBALL-2), and Water Mist Fire Suppression Experiment (Mist).

LSP-2 and SOFBALL-2 are reflights from the Microgravity Sciences Laboratory 1; Mist is a new experiment. They are detailed in separate fact sheets.

CM-2 will complete the primary science plan for these investigations, and help set the stage for expanded, long-term experiments aboard the *International Space Station* with the Fluids and Combustion Facility that will be installed in Destiny, the U.S. lab module.

Background Information

CM-2 Background

The Combustion Module (CM) is a state-of-the-art space laboratory to let a wide range of users perform combustion experiments in space. Until 1997, combustion experiments were developed for individual experiments. This was time-consuming and costly. NASA decided that a better and less expensive approach was a reusable, modular combustion facility that could accommodate diverse experiments with the same support hardware and unique Experiment Mounting Structures (EMS). This approach led to the CM.

CM-2 Design

Most CM-2 subsystems are in a double rack and a single rack standing side-by-side in the SPACEHAB module. Flight spares and EMS's are carried in a Maximum Envelope Stowage System that is the same size as a double rack. Central to the CM-2, in the double rack, is the Experiment Package, a 90-liter combustion chamber with six ports for three intensified near-infrared cameras, one color camera, and three black and white cameras; a gas chromatograph; crew switches; and thermistors. The Fluid Supply Package, in the single rack, is a complex gas control and distribution system containing 20 composite overwrapped compressed gas bottles.

The Videocassette Recorder Package consists of four Hi-8 video recorders. The Exhaust Vent Package includes a blower, canister, and other fluid components for cleanup and evacuation of chamber gases. The Dedicated Experiment Processor Package is the main processor for experiment command and control, and connects to the crew laptop (the CM-2 human interface). The Video Interface Package is the primary video interface for switching, routing, and display. The Diagnostic Processor Package is the video frame grabber and storage system for digital data. The Power Distribution Package controls and conditions the power from the Shuttle/SPACEHAB for all CM-2 packages. Finally, the EMS are experiment-unique chamber inserts. Each contains an ignition system and special sensors; the Mist EMS also contains test gases, a water mist generator, and a canister to remove water and carbon monoxide after each test.

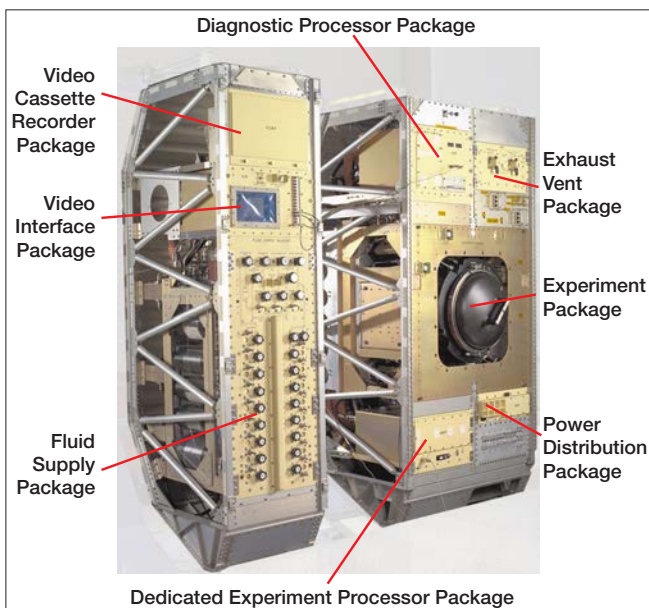

CM-2 Statistics

Size: Main racks — 2.13 m tall by 1.52 m wide by 0.91 m deep (7×5×3 ft)
Weight: Main racks — 835 kg (1840 lb); other CM-2 hardware — 161 kg (355 lb)
Subsystems: Eight rack-mounted components, three chamber inserts
Power Usage: Average — 419 W (dc); Peak — 543 W (dc)
Chamber Size: 40 cm (16 in.) dia. × 76 cm (30 in.) long; 91 liters (23.4 gal.) empty
Cameras: Seven — one color, three intensified near-infrared, three black and white
Lasers: Two sets of low-power beams for LSP and Mist measurements
Sensors: Dozens of pressure, temperature, and radiation sensors
Gas Analysis: Gas chromatograph determines percent of each kind of gas
Gas Bottle Sizes: 21 — three × 10 liters, nine × 3.8 liters, eight × 0.7 liters, one × 0.4 liters
Gas Bottle Usage: Fourteen SOFBALL mixes, two air, two LSP fuel, three gas chromatographs
Software: Three 25 MHz computers, ~35,000 lines of code
Video: Four VCRs, frame grabber, and two-channel downlink capability; 15.2 cm (6-in.) diagonal screen onboard
Data: 13.3 gigabytes storage (20 hard drives/flash memory cartridges)
Crew Time: 92 hours

Flight Operations

Although the flight crew is in the spotlight for shuttle missions, a team of engineers, scientists, and other support personnel on the ground will make it all possible. The CM-2 team, comprising almost 40 engineers and scientists, will work side-by-side with the NASA Johnson Space Center Mission Control team in Houston, TX. For STS-107, 16 days of around-the-clock operations are conducted to ensure safety and mission success. The CM-2 experiments timeline spans the entire mission.

The LSP experiment includes 15 burns lasting about five minutes each, with active participation by the crew to adjust test conditions during the burn. The 15 SOFBALL burns range from 25 to 167 minutes each, during which the Shuttle is placed in “free drift” with no attitude control so that the flame balls float freely inside the combustion chamber. The crew checks on the flame balls every ten minutes and adjusts camera gains as needed. The 36 Mist burns are each very short ranging from less than one second to several seconds in duration. Mist includes six tests run by the crew and 30 tests run by the ground team using commands sent directly to CM-2's on-board computer.

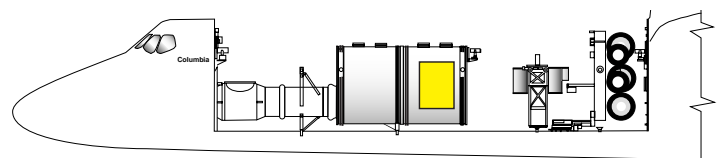

Approximate location of this payload aboard STS-107.

Photos. Page 1 from top: University of Michigan at Ann Arbor, University of Southern California, Colorado School of Mines; page 2, NASA.

FS-2002-06-070-MSFC



Stirring Up an Elastic Fluid Critical Viscosity of Xenon-2 (CVX-2)

Whipped cream stays in place even when turned upside down. Yet it readily flows through the nozzle of a spray can to reach the dessert plate. This demonstrates the phenomenon of shear thinning that is important to many industrial and physical processes. Paints, film emulsions, and other complex solutions that are highly viscous under normal conditions but become thin and flow easily under shear forces.



Whipped cream and the filling for pumpkin pie are two familiar materials that exhibit the shear-thinning effect seen in a range of industrial applications. It is thick enough to stand on its own atop a piece of pie, yet flows readily when pushed through a tube. Shear thinning will cause a normally viscous fluid (below) to deform and flow more readily under high shear conditions.

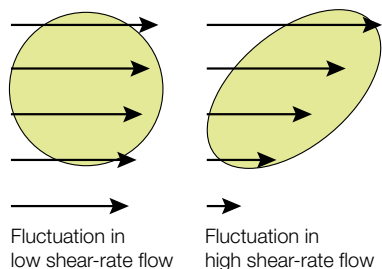

Principal Investigator: Dr. Robert F. Berg, National Institute of Standards and Technology, Gaithersburg, MD
Co-principal Investigator: Dr. Michael R. Moldover, National Institute of Standards and Technology, Gaithersburg, MD
Project Scientist: Dr. Gregory A. Zimmerli, NASA Glenn Research Center, Cleveland, OH
Project Manager: Susan M. Motil, NASA Glenn Research Center, Cleveland, OH

xenon, a heavy inert gas used in flash lamps and ion rocket engines, at its critical point. Although it does not easily combine with other chemicals, its viscosity at the critical point can be used as a model for a range of fluids.

Viscosity originates from the interactions of individual molecules. It is so complicated that, except for the simplest gas, it cannot be calculated accurately from theory. Tests with critical fluids can provide key data, but are limited on Earth because critical fluids are highly compressed by gravity. CVX-2 employs a tiny metal screen vibrating between two electrodes in a bath of critical xenon. The vibrations and how they dampen are used to measure viscosity.

CVX flew on STS-85 (1997), where it revealed that, close to the critical point, the xenon is partly elastic: it can “stretch” as well as flow. For STS-107, the hardware has been enhanced to determine if critical xenon is a shear-thinning fluid.

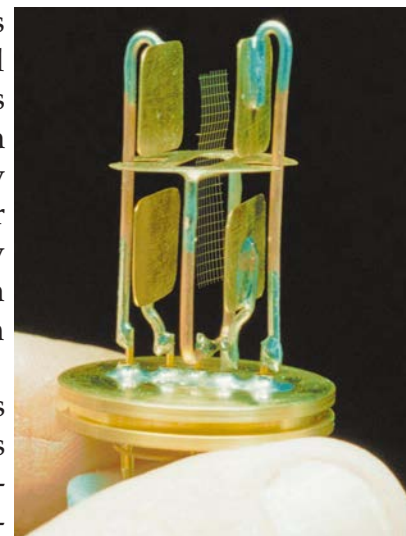

Resembling a bit of window screen, the oscillator at the heart of CVX-2 will vibrate between paddle-like

Applications

Understanding shear thinning in a simple fluid such as xenon may help scientists understand more complex, industrially important fluids, such as:

- Paints, emulsions, and foams
- Polymer melts
- Pharmaceutical, food, and cosmetic products.

Affected Fields

Hydrodynamics: Nonlinear response to oscillatory flows of moderate amplitude.

Physics: Universal behavior of pure fluids at the liquid-vapor critical point.

Background Information

Science

Viscosity — the “thickness” of fluids — is determined by complex interactions between molecules. Except for low density helium, fluid viscosity cannot be predicted accurately by current theory. Progress is being made with experiments using simple fluids near their critical points, a combination of pressure and temperature at which a fluid is balanced between the liquid and gaseous states. This causes the fluid to fluctuate spontaneously between liquid and gas at a microscopic scale. It is somewhat like a soft drink with carbonation bubbling in and out.

Experiments on Earth are highly limited. At 0.001 °C above its critical temperature (T_c), xenon (a heavy, inert gas) is 6,000 times more compressible than air. Even a fluid layer as thin as a dime (1mm) compresses under its own weight. Experiments in the microgravity of orbit eliminate density differences and allow extended experiments to achieve the precision that scientists need.

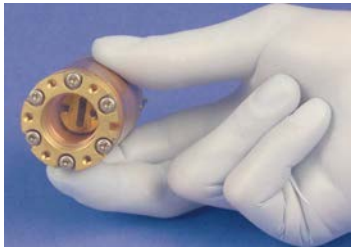
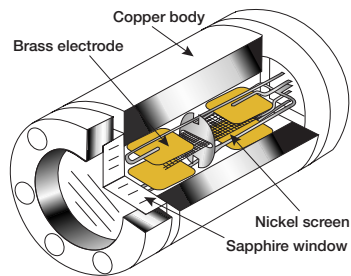

The sample cell (top) at the heart of CVX comprises a copper body (above) that conducts heat efficiently and smooths out thermal variations that would destroy the xenon's uniformity. The cell sits inside a thermostat (bottom) providing three layers of insulation.

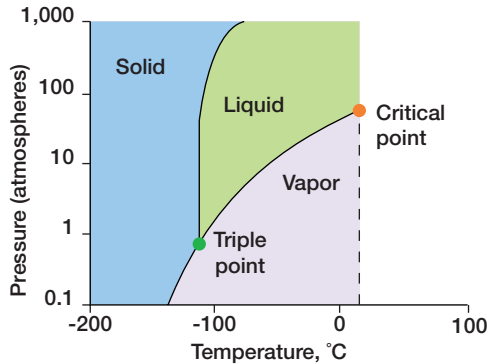

Different combinations of temperature and pressure will change the xenon's phase, or allow two or three phases to exist simultaneously.

Experiments in the microgravity of orbit eliminate density differences and allow extended experiments to achieve the precision that scientists need.

Flight Research Equipment

The heart of CVX-2 is a nickel screen that vibrates between two pairs of brass electrodes in a xenon bath. The grid is 7 × 19 mm (0.28 × 0.74 in) and weighs less than 1 mg. An electrode is positioned 4 mm (0.16 in) to each side of the screen. An electrical charge applied by the electrodes will oscillate the screen. The electrodes measure the screen's displacement and period, like a pendulum swinging in a liquid. The cell holds a small quantity of xenon near its critical temperature ($T_c = 16.6$ °C, or 62 °F) and critical density (1.1 times that of water) at 58 atmospheres, equivalent to a depth under water of almost 0.6 kilometer (1,914 ft).

The experiment plan involves four “sweeps” as the temperature gently moves up and down through T_c while the screen oscillates and data are continuously recorded. CVX-2 will determine T_c to within 0.001 °C. These first results will be compared to those from CVX.

On CVX, the screen oscillated at less than 13 cycles per second (13 Hz) through a distance of less than 0.01 mm, less than the thickness of a hair, to avoid disrupting the density fluctuations in the xenon. On CVX-2, the screen vibrates at up to 25 Hz and amplitudes of 0.3 mm in a deliberate attempt to disrupt the density fluctuations and cause shear thinning.

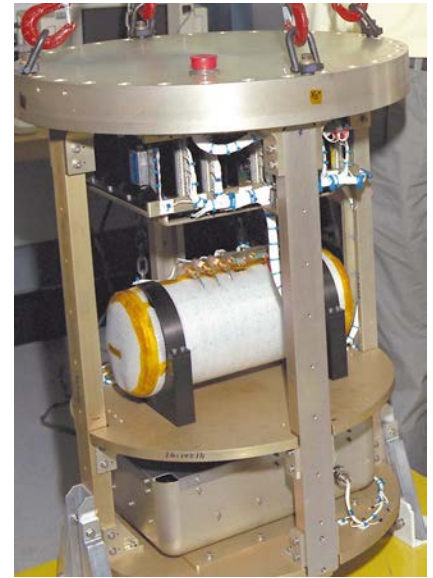

The thermostat for CVX sits inside the white cylinder on a support structure that is placed inside a pressure canister. A similar canister holds the electronics and control systems. The CVX-2 arrangement is identical.

On CVX-2, the screen vibrates at up to 25 Hz and amplitudes of 0.3 mm in a deliberate attempt to disrupt the density fluctuations and cause shear thinning.

Previous Results

CVX operated well on its first flight on STS-85 in 1997. It accurately measured the viscosity of xenon to within 0.0001 °C of T_c and showed a viscosity increase of 37 percent, double the best measurements on Earth. CVX also showed that xenon's viscoelastic response (a partly elastic response to shear stress) was twice as great as predicted by theory. The results were published in two journals, *Physical Review Letters* [82, 920 (1999)] and *Physical Review E* [60, 4079 (1999)].

Because xenon near the critical point will compress under its own weight, experiments on Earth (blue line) are limited as they near the critical point (to the left). In the microgravity (red line), CVX moved into new territory that scientists had not been able to reach.

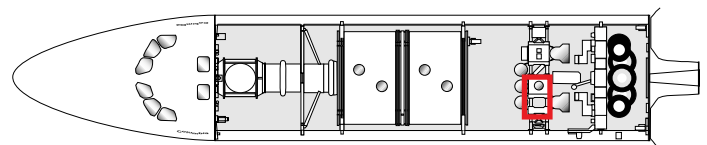
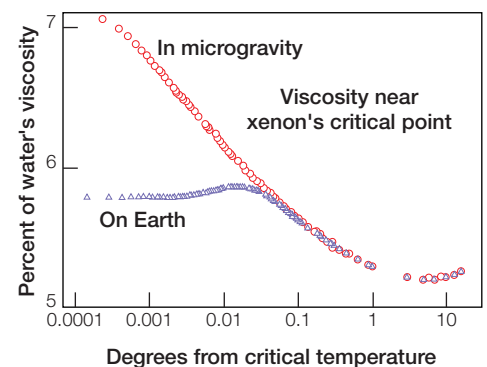

Approximate location of this payload aboard STS-107.

Photos. NASA, National Institute of Standards and Technology.

FS-2002-06-069-MSFC



Tackling a Hot Paradox Laminar Soot Processes-2 (LSP-2)

The last place you want to be in traffic is behind the bus or truck that is belching large clouds of soot onto your freshly washed car. Besides looking and smelling bad, soot is a health hazard. Particles range from big enough to see to microscopic and can accumulate in the lungs, potentially leading to debilitating or fatal lung diseases.

Soot is wasted energy, and therein lies an interesting paradox: Soot forms in a flame's hottest regions where you would expect complete combustion and no waste. Soot enhances the emissions of other pollutants (carbon monoxide and polyaromatic hydrocarbons, etc.) from flames and radiates unwanted heat to combustion chambers (a candle's yellowish glow is soot radiating heat), among other effects.



Soot belched by a diesel engine is more than ugly — it's dangerous. While the largest particles may wash out of the air when it rains, smaller particles linger and possibly endanger human health and the environment.

The mechanisms of soot formation are among the most important unresolved problems of combustion science because soot affects contemporary life in so many ways. Although we have used fire for centuries, many fundamental aspects of combustion remain elusive, in part because of limits imposed by the effects of gravity on Earth. Hot or warm air rises quickly and draws in fresh cold air behind it, thus giving flames the classical teardrop shape. Reactions occur in a very small zone, too fast for scientists to observe, in detail, what is happening inside the flame.

The Laminar Soot Processes (LSP-2) experiments aboard STS-107 will use the microgravity environment of space to eliminate buoyancy effects and thus slow the reactions inside a flame so they can be more readily studied. "Laminar" means a simple, smooth fuel jet burning in air, somewhat like a butane lighter. This classical flame approximates combustion in diesel engines, aircraft jet propulsion engines, and furnaces and other devices.

LSP-2 will expand on surprising results developed from its first two flights in 1997. The data suggest the existence of a universal relationship, the soot paradigm, that, if proven, will be used to model

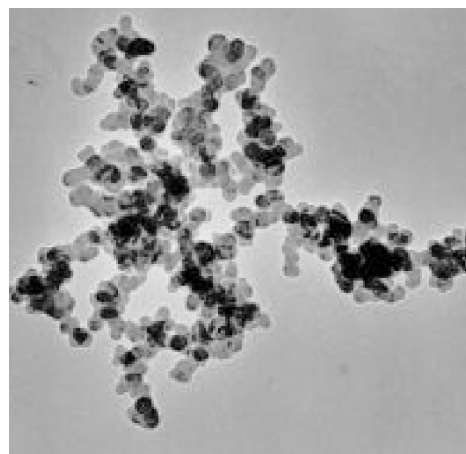

Soot particles from MSL-1 experiments (top) are about 10 to 60 nm across and formed aggregates 1,000 nm (1 micron) wide. This is similar to soot formed in terrestrial sources.

and control combustion systems on Earth. STS-107 experiments also will help set the stage for extended combustion experiments aboard the *International Space Station*.

Applications

Fine-tune burner design and operation to:

- Control soot production in combustion processes,
- Reduce radiative heat transfer from soot particles that can damage engines
- Improve electric power generation efficiency by increasing radiative transfer from soot in flame to furnace walls while maintaining complete soot burnout (no emission),
- Enhance soot production in processes for carbon black used in tires and applications,
- Enhance computational combustion studies to design new systems that are optimized at the start, and retrofit existing systems.

Principal Investigator: Prof. Gerard M. Faeth, The University of Michigan, Ann Arbor, MI

Project Scientist: Dr. David L. Urban, NASA Glenn Research Center, Cleveland, OH

Project Manager: Ann Over, NASA Glenn Research Center, Cleveland, OH

Background Information

Science

Microgravity provides an unprecedented opportunity to investigate soot processes relevant to practical flames. The chemical pathways that form soot are highly controversial in the science community. When the flame temperature falls below about 1300 °K (1900 °F), no soot is formed. Above that, hydrocarbon fuels pyrolyze or break down, even as most of the reactions form carbon dioxide and water vapor. These molecular fragments produce other molecules, including polycyclic aromatic hydrocarbons (PAH's) that coalesce into solid carbonaceous particles — soot — that are linked to human cancers in a number of studies.

The LSP investigation observes soot processes within laminar jet diffusion flames where a hydrocarbon jet burns in still air. Microgravity produces nonbuoyant laminar jet flames which allow observations of soot processes that cannot be duplicated on Earth. Normal gravity generates buoyant motion due to the large variations of gas densities in flames. These motions introduce soot particle motions that do not represent most practical flame environments where local effects of buoyancy are small.

Hardware

LSP-2 experiments will be conducted inside the Combustion Module (CM-2) facility flown in 1997 and modified for SPACEHAB. CM-2 will also host the Structure of Flame Balls at Low-Lewis number -2 (SOFBALL-2) and Water Mist experiments. CM-2 is detailed in a separate fact sheet. Diagnostic instruments for LSP include a color camera, a soot volume fraction system (using the dimming of a laser shining through the flame), and a soot temperature

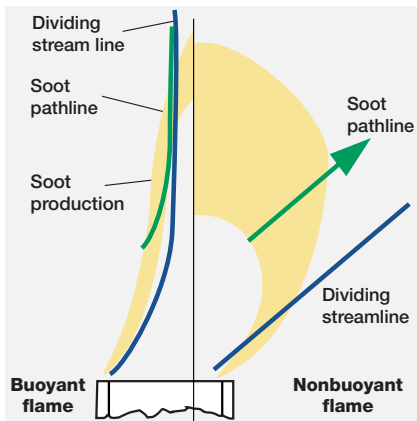

In buoyant flames (bottom left), soot mainly nucleates at the outer boundary of the soot production region, then moves inward before approaching the flame sheet once again near the flame tip. In nonbuoyant flames (bottom center and right), soot mainly nucleates near the inner boundary of the soot production region, and then is drawn directly toward the flame sheet.

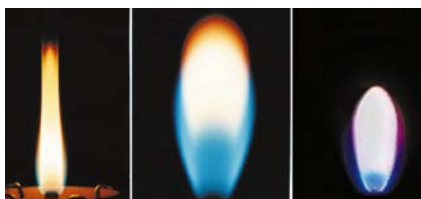

Dr. Roger Crouch, a payload specialist on MSL-1, services the LSP experiment.

Affected Fields

Transportation: Internal combustion engines on aircraft (jet and piston), rail, ships, trucks, buses.

Industry: Power plants, process plants that use combustion heating.

Safety: Reduced loss of life and property due to improved understanding of building fires.

measurement system. An Experiment Mounting Structure provides a large volume to allow laminar flames to form on one of two burners with diameters of 0.4 mm (0.016 in.) and 0.8 mm (0.0315 in.). They produce a flame 20 to 60 mm long (0.8 to 2.4 in.). Soot samplers (for six test points) snap through the flame to capture particles for post-flight analysis.

On-Orbit Operations

LSP-2 science operations will last almost 42 hours and cover 15 test points using ethylene or propane fuel in air. LSP-2 is operated by the flight crew through a laptop computer connected to the CM-2. Setting the smoke height will require guidance from the science team at Johnson Space Center.

Previous Results

On the Microgravity Sciences Lab-1 mission in 1997, LSP yielded several surprises. The LSP team discovered a new mechanism of flame extinction caused by radiation from soot. The mechanism is unusual because the flame quenches near its tip, unlike conventional extinction of buoyant flames where the flame quenches near its base. This phenomenon has significant implications for spacecraft fire safety and for selecting test conditions for future studies of nonbuoyant soot-containing flames. The team also made the first observations of steady soot-containing nonbuoyant flames both with and without soot emissions. These provided textbook examples of soot formation processes in practical flames that are invaluable for developing methods for controlling the emissions of pollutant soot.



LSP uses a small jet burner, similar to a classroom butane lighter, that produces flames up to 60 mm (2.3 in) long. Measurements include color TV imagery (above), and laser shadowgraphs whose dimming indicates the quantity of soot produced in the flame (below).

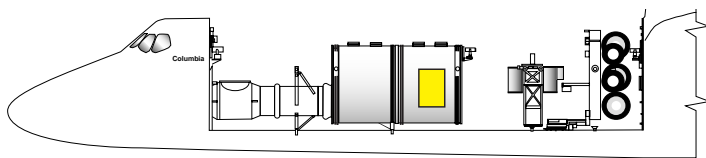
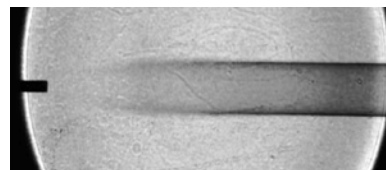

Approximate location of this payload aboard STS-107.

Photos. NASA, University of Michigan at Ann Arbor.

FS-2002-06-072-MSFC



Mechanics of Granular Materials-3 (MGM-3)

Experiment Name: Mechanics of Granular Materials-3 (MGM-3)

Mission: STS-107

Experiment Location: SPACEHAB Module

Principal Investigator: Dr. Stein Sture, University of Colorado at Boulder

Project Scientist: Dr. Khalid Alshibi, Louisiana State University-Southern University, Baton Rouge, La.

Project Manager: Buddy Guynes, NASA Marshall Space Flight Center, Huntsville, Ala.

Overview

Scientists are going to space to understand how earthquakes and other forces disturb grains of soil and sand. They will examine how the particle arrangement and structure of soils, grains and powders are changed by external forces and gain knowledge about the strength, stiffness and volume changes properties of granular materials at low pressures.

The Mechanics of Granular Materials (MGM) experiment uses the microgravity of orbit to test sand columns under conditions that cannot be obtained in experiments on Earth. Research can only go so far on Earth because gravity-induced stresses complicate the analysis and change loads too quickly for detailed analysis.

This new knowledge will be applied to improving foundations for buildings, managing undeveloped land, and handling powdered and granular materials in chemical, agricultural, and other industries. NASA wants to understand the way soil behaves under different gravity levels so that crews can safely build habitats on Mars and the Moon.

Future MGM experiments will benefit from extended tests aboard the International Space Station, including experiments under simulated lunar and Martian gravity in the science centrifuge.



Flight History

MGM has flown twice on the space shuttle (STS-79 and -89), involving nine dry sand specimens. Several significant finds have emerged from these flights and are helping scientists test a number of hypotheses about soil behavior. For example, results showed strength properties two to three times greater and stiffness properties 10 times greater than conventional theory predicted.

Experiment Operations

On STS-107, scientists will investigate conditions with water-saturated sand resembling soil on Earth. Three sand specimens will be used in nine experiments.

The heart of the experiment is a column of sand held in a latex sleeve and compressed between tungsten metal plates. Each cell uses about 1.3 kilograms (2.8 pounds) of Ottawa F-75 banding sand, 7.5 centimeters in diameter by 15 centimeter wide (3 x 6 inches). Ottawa sand, natural quartz sand with fine grains, is widely used in civil engineering experiments.

The specimen assembly is contained in a water-filled Lexan jacket. A load cell measures force, and three CCD cameras videotape the experiment. The flight crew controls the experiment through a laptop computer. The system takes the volume of four middeck lockers in the SPACEHAB module.

After return to Earth, computed tomography (CT) scans produce a series of 1024 x 1024-pixel images to make three-dimensional images showing internal details. Then, specimens are stabilized by injecting epoxy in sand pores. Finally, the columns are sawed into 1-millimeter (0.4 inch) thick disks for detailed inspection under an optical microscope.

Applications

- Soil mechanics, geotechnical engineering
- Earthquake engineering
- Mining of open pits, strip mines, tunnels, shafts
- Grain silos, powder feed systems, coal, ash, pharmaceuticals, and fertilizers
- Coastal and offshore engineering
- Geology and geophysics of wind and water erosion of soils, slope development and decay, deposit of volcanic materials



- Off-road vehicle engineering
- Planetary geology
- Microgravity handling of powders

More information on the MGM experiment and other STS-107 experiments is available at:

<http://spaceresearch.nasa.gov/>
www.scipoc.msfc.nasa.gov
www.spaceflight.nasa.gov
<http://www.microgravity.nasa.gov>

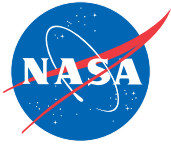

The Awful Truth About Zero-Gravity

Space Acceleration Measurement System; Orbital Acceleration Research Experiment

Earth's gravity holds the Shuttle in orbit, as it does satellites and the Moon. The apparent weightlessness experienced by astronauts and experiments on the Shuttle is a balancing act, the result of free-fall, or continuously falling around Earth.

An easy way to visualize what is happening is with a thought experiment that Sir Isaac Newton did in 1686. Newton envisioned a mountain extending above Earth's atmosphere so that friction with the air would be eliminated. He imagined a cannon atop the mountain and aimed parallel to the ground. Firing the cannon propels the cannonball forward. At the same time, Earth's gravity pulls the cannonball down to the surface and eventual impact. Newton visualized using enough powder to just balance gravity so the cannonball would circle Earth. Like the cannonball, objects orbiting Earth are in continuous free-fall, and it appears that gravity has been eliminated.

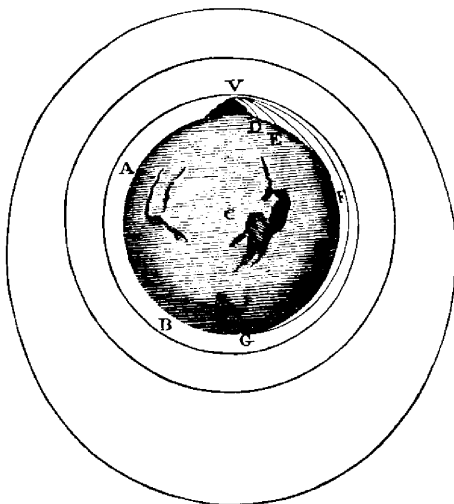

Newton's Thought Experiment: A cannonball fired with enough force could fall endlessly around (or orbit) the Earth.

Yet, that appearance is deceiving. Activities aboard the Shuttle generate a range of accelerations that have effects similar to those of gravity. The crew works and exercises. The main data relay antenna quivers 17 times per second to prevent 'stiction,' where parts stick then release with a jerk.

Activities aboard the Shuttle generate a range of accelerations that have effects similar to those of gravity. The crew works and exercises. The main data relay antenna quivers 17 times per second to prevent 'stiction,' where parts stick then release with a jerk.

SAMS Shuttle Project Manager: Ronald J. Sicker, Glenn Research Center, Cleveland, OH
PIMS Project Manager: Kevin M. McPherson, Glenn Research Center, Cleveland, OH

Cooling pumps, air fans, and other systems add vibration. And traces of Earth's atmosphere, even 200 miles up, drag on the Shuttle.

While imperceptible to us, these vibrations can have a profound impact on the commercial research and scientific experiments aboard the Shuttle. Measuring these forces is necessary so that researchers and scientists can see what may have affected their experiments when analyzing data. On STS-107 this service is provided by the Space Acceleration Measurement System for Free Flyers (SAMS-FF) and the Orbital Acceleration Research Experiment (OARE). Precision data from these two instruments will help scientists analyze data from their experiments and eliminate outside influences from the phenomena they are studying during the mission.

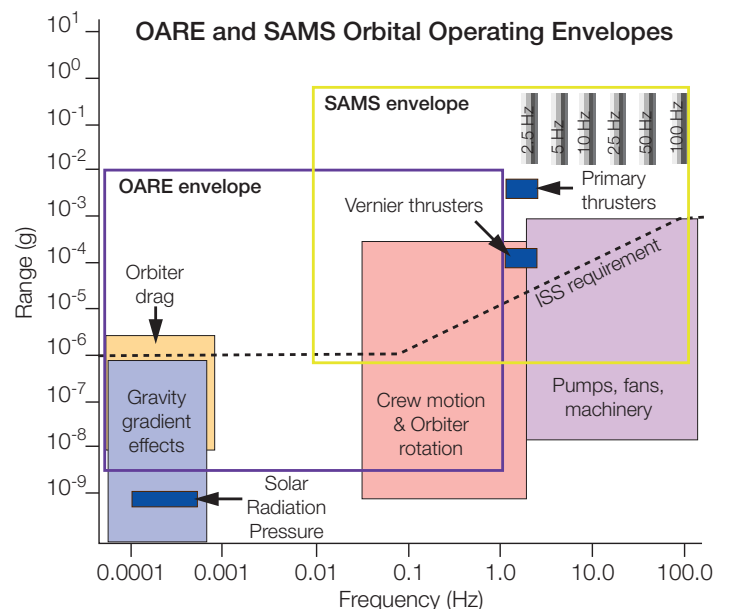

SAMS and OARE will record data in two separate areas of the vibration spectrum, and with a modest amount of overlap. Different activities have different effects on sensitive payloads on the Shuttle, and the broad range that each has. Frequency (Hz) indicates vibrations per second. Notice that "0-g" is never reached.

Background Information

The primary means for scientists to learn more about the microgravity conditions affecting their research is from the Space Acceleration Measurement System (SAMS). The SAMS system is produced by the Microgravity Environment Program (MEP) at the NASA Glenn Research Center. The MEP produces a variety of microgravity measurement hardware for on-orbit spacecraft (the *International Space Station (ISS)* and the Space Shuttle) and ground-based flights (drop towers, parabolic aircraft, and sounding rockets). The various SAMS (SAMS, SAMS-FF (free flyer), and SAMS-II) have supported 22 shuttle missions, and the Mir space station, and provide long-term support on the ISS. STS-107 will use a SAMS-FF. This is the second Shuttle mission for the SAMS-FF, which is a third-generation SAMS system. It uses industrial-grade components to provide a flexible, modular system that is easily customized for each particular mission.

Space Acceleration Measurement System-Free-Flyer

SAMS-FF consists of a control and data acquisition unit (CDU), three remote acceleration sensor heads, and a fiber-optic gyroscope (FOG). The CDU is similar to a desktop computer packaged to meet the rigors of spaceflight. It controls the operation from the ground and process data from the sensors through a telemetry data stream, which can be seen on NASA computers on the ground. This lets experimenters view the data collected during the mission so they can correlate their science results with the SAMS data in real time. Three accelerometers are precisely mounted at right angles to form a triaxial sensor head (TSH). This allows the sensor head to detect vibrations in three different directions of movement: what would be on Earth up and down, forward and backward, and side-to-side (called X, Y, and Z axes). The data are processed to provide the resultant vector of the magnitude and direction, as well as the frequency content, of various time intervals. The TSH is a microcontroller-based data acquisition system capable of measuring the microgravity accelerations of the Shuttle. Sensitive inertial grade accelerometers are used to resolve the very low forces experienced during quiet periods and have the dynamic range to measure the larger vibration disturbances.



SAMS-FF includes the control data unit (left), a triaxial sensor head (center) and the fiber-optic gyroscope (right). Two additional triaxial sensor heads will be remotely mounted with payloads.

A new sensor on STS-107 is a fiber-optic gyroscope (FOG). To fully capture the motion of the vehicle, not only are the forces examined in three linear directions, but also the rotation of the vehicle is measured to understand the torque forces. FOG has no moving parts and is used to measure precisely the roll, pitch, and yaw of the shuttle. It does this by comparing the phases of beams of light traveling in opposite directions around a very long coil of fiber. If there is no rotation, the beams recombine at exactly the same phase. However, if the coil is rotated in a particular direction, travel takes longer in the opposite direction before it exits the coil. This difference is detected by sensitive electronic circuits to determine the rate at which the rotation occurs. Lower grade versions of FOG gyroscopes are used in automobiles, combined with GPS data for electronic positioning displays.

Orbital Acceleration Research Experiment

In addition to SAMS, the OARE accelerometer system characterizes (measures) the quasi-steady acceleration environment. OARE measures very low frequency microgravity accelerations caused by upper atmospheric drag (as the shuttle passes through the upper atmosphere), rigid body inertial rotations, gravity-gradient effects, shuttle's mass expulsion, and crew activities. OARE acceleration data complement that of SAMS by providing the scientists a more thorough understanding of the various accelerations that can affect the experiments onboard the shuttle or any orbiting spacecraft in a low Earth orbit.

Principal Investigator Microgravity Services

The PIMS group at NASA Glenn is responsible for processing, analyzing, and archiving the acceleration data measured by the two accelerometer systems previously described. During STS-107, acceleration data will be transmitted to the ground via telemetry links for real-time processing and analysis so that the scientists can assess the impact of the reduced-gravity environment in near real time on their experiments. Specialized displays are developed by the PIMS group to help the scientists make near real-time decisions in order to lessen the impact of the reduced-gravity environment on their science results, thereby maximizing good science data collection. PIMS will prepare an STS-107 mission microgravity characterization summary report which will highlight the reduced-gravity environment during the STS-107 mission to help the scientists take into account the adverse impact of the environment on their science results. PIMS will provide real-time support and post mission support to the Combustion Module-2 (CM-2) facility.

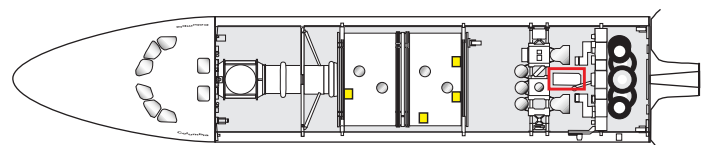

Approximate locations of this payload aboard STS-107.

Picture credits. NASA.

FS-2002-06-073-MSFC



Great (Flame) Balls of Fire!

Structure of Flame Balls at Low Lewis-number-2 (SOFBALL-2)

Everyone knows that an automobile engine wastes fuel and energy when it runs with a fuel-rich mixture. “Lean” burning, mixing in more air and less fuel, is better for the environment. But lean mixtures also lead to engine misfiring and rough operation. No one knows the ultimate limits for lean operation, for “weak” combustion that is friendly to the environment while still moving us around.



Flame balls (seen in a 1997 space experiment) seem to shine bright as stars, but only because they are observed in the dark by a video camera with an image intensifier. Under normal lighting in a space module, the flame balls would be invisible — to the eye and to fire detectors — and thus potentially hazardous.

This is where the accidental verification of a decades-old prediction may have strong implications for designing and running low-emissions engines in the 21st century. In 1944, Soviet physicist Yakov Zeldovich predicted that stationary, spherical flames are possible under limited conditions in lean fuel-air mixtures.

Dr. Paul Ronney of the University of Southern California accidentally discovered such “flame balls” in experiments with lean hydrogen-air mixtures in 1984 during drop-tower experiments that provided just 2.2 seconds of near weightlessness. Experiments aboard NASA’s low-g aircraft confirmed the results, but a thorough investigation was hampered by the aircraft’s bumpy ride. And stable flame balls can only exist in microgravity.

The potential for investigating combustion at the limits of flammability, and the implications for spacecraft fire safety, led to the Structure of Flame Balls at Low Lewis-number (SOFBALL) experiment flown twice aboard the Space Shuttle on the

Microgravity Sciences Laboratory-1 (MSL-1) in 1997. Success there led to the planned reflight on STS-107.

Flame balls are the weakest fires yet produced in space or on Earth. Typically each flame ball produced only 1 watt of thermal power. By comparison, a birthday candle produces 50 watts.

The Lewis-number measures the rate of diffusion of fuel into the flame ball relative to the rate of diffusion of heat away from the flame ball. Lewis-number mixtures conduct heat poorly. Hydrogen and methane are the only fuels that



Applications

- Lean-burning car engines under consideration to meet California’s ultra low emissions standards, or natural-gas powered cars, like the test model (above) in New York.
- Assessment of fire and explosion hazards in mine shafts, oil refineries, and chemical plants.
- Spacecraft safety where gases from waste systems or fuel cells could provide a fuel source for long-lived flame balls.

provide low enough Lewis-numbers to produce stable flame balls, and even then only for very weak, barely flammable mixtures. Nevertheless, under these conditions flame balls give scientists the opportunity to test models in one of the simplest combustion experiments possible. SOFBALL-2 science objectives include:

- Improving our understanding of the flame ball phenomenon,
- Determining the conditions under which flame balls exist,
- Testing predictions of flame ball lifetimes, and
- Acquiring more precise data for critical model comparison.

Principal Investigator: Dr. Paul Ronney, University of Southern California, Los Angeles

Project Scientist: Dr. Karen J. Weiland, NASA Glenn Research Center, Cleveland, OH

Project Manager: Ann Over, NASA Glenn Research Center, Cleveland, OH

Background Information

Science

SOFBALL burns extremely lean fuel-air mixtures that are near the lower limit of combustion. Because the mixture is lean and has a low Lewis-number, the flame does not spread across the mixture. It forms a spherical shell filled with combustion products. Fuel and oxygen diffuse inward while heat and combustion products diffuse outward. This diffusion-controlled combustion process produces the weakest known flames and provides a mechanism to study the limits of lean combustion. This works only in the micro-gravity environment, in the absence of buoyant flow that would otherwise overwhelm diffusion.

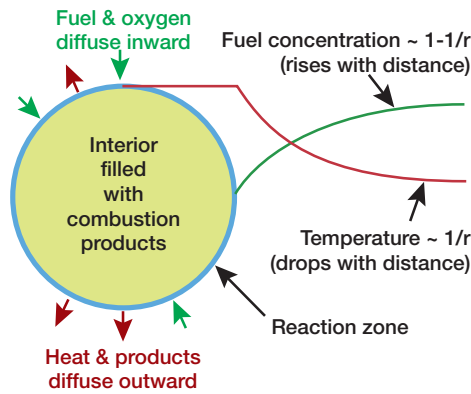

All the combustion in a flame ball takes place in a razor-thin reaction zone that depends on diffusion to keep the ball alive (above). Such a fragile balance is impossible on Earth. Flame balls always drift away from each other (below) at a continually decreasing rate, indicating that they move into areas of greater fuel concentration.

Hardware

SOFBALL-2 experiments will be conducted inside the Combustion Module-2 (CM-2) facility flown on Spacelab in 1997 and modified for flight on SPACEHAB. CM-2 will also host the Laminar Soot Processes (LSP) and Water Mist experiments. CM-2 is described in a separate fact sheet.

The SOFBALL-2 Experiment Mounting Structure in CM-2 is a cylinder about 62 cm long and 40 cm in diameter (24.4 × 15.7 in), and weighs approximately 39 kg (87 lb). The main components are the spark igniter; temperature sensors, arranged as a rake of six thin thermocouple wires; two pairs of radiometers; a mixing fan; and volume compensators to reduce the amount of gas needed for each test. Improvements for SOFBALL-2 include longer tests times, two new gas mixtures, addition of a close-up camera, and using an accelerometer for real-time decisions during tests.

Affected Fields

Combustion physics: Study the simplest interaction of chemistry and transport.

Spacecraft design: Systems that handle hydrogen or biological products (food, waste, lab animals) that produce hydrogen and other combustible gases.

Automotive engineering: Design of lean-burning engines using pure hydrogen or using hydrocarbon fuels in which hydrogen combustion is a significant component.

On-Orbit Operations

The flight crew will run the first three test points through the CM-2 laptop computer. The SOFBALL science team on Earth will adjust conditions from one burn to the next, but the flight crew will initiate combustion, determine whether flame balls exist, adjust and monitor instruments, terminate the experiment, and initiate a reburn if needed. SOFBALL operations will take about 160 hours of flight time. Key science measurements include: flame ball size, brightness, temperature, radiant emission, lifetime, and combustion product composition.



Dr. Janice Voss, a mission specialist services the CM during MSL-1 in 1997.

SOFBALL test points will use five gas combinations — hydrogen-air, hydrogen-oxygen-sulfur hexafluoride, hydrogen-oxygen-carbon dioxide, hydrogen-oxygen-carbon dioxide-helium, and methane-oxygen-sulfur hexafluoride — at 1 to 3 atmospheres, each with varying concentrations. Flame balls will burn for 1,500 to 10,000 seconds (almost 2.8 hours) depending on experiment objectives.

Previous Results

The biggest discovery from the first SOFBALL flights (MSL-1 and 1R) was the long life of flame balls. Scientists expected that flame balls would extinguish or drift into the chamber walls in a few minutes. Instead, most could have burned for hours had they not been automatically terminated at 500 seconds. The experiments also provided conclusive evidence about the limitations of existing computer models of lean combustion, and demonstrated the effects of flames reabsorbing their own radiation, which can also affect large engines and industrial boilers.

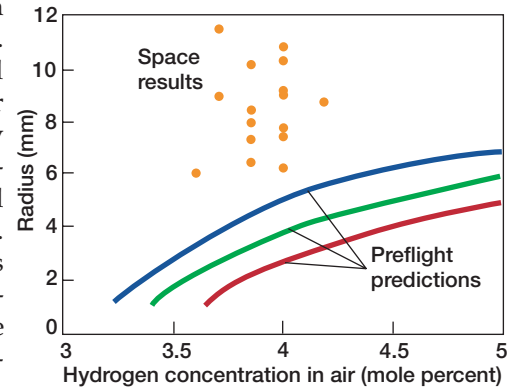

Theory does not always predict behavior. Predictions for hydrogen-air flame balls were quite different from SOFBALL tests on MSL-1.

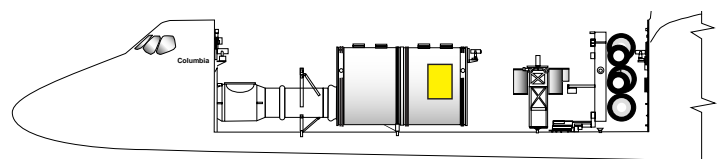

Approximate location of this payload aboard STS-107.

Photos. NASA, New York State Dept. of Transportation (auto); University of Southern California (diagrams).

FS-2002-06-071-MSFC



ASTROCULTURE™ Commercial Plant Growth Unit and Glove Box Insert

Experiment Name: ASTROCULTURE™ Commercial Plant Growth Unit and Glove Box Insert

Mission: STS-107

Experiment Location: SPACEHAB Module

Commercial Space Center: Wisconsin Center for Space Automation and Robotics (WCSAR), University of Wisconsin-Madison

Project Manager and Commercial Space Center Director: Dr. Weijia Zhou

Industry Partner for Gene Transfer Experiment: Producers' Natural Processing Inc., West Laffeyatt, Ind.

Industrial Partner for Essential Oil Production Experiment: International Flavors and Fragrances, New York

Commercial Space Center Manager: Steve Lambing, NASA Marshall Space Flight Center, Huntsville, Ala.

Overview

Two commercial plant investigations will be conducted during the STS-107 mission: living flower essential oil production and gene transfer. The research will be done using the ASTROCULTURE™ hardware, which builds on similar experiments flown in the past on the space shuttle.

A miniature rose was grown in space for the first time during the STS-95 space shuttle mission in the fall of 1998. Scientists at the company sponsoring this research – International Flavors and Fragrances in New York – verified that microgravity altered the fragrance of the rose and produced a new scent.

The fragrance ingredient produced in space was incorporated into two commercial products: a perfume, called Zen, developed by Shiseido in 2000 and a body spray, called Impulse, developed by Unilever in early 2002. The search for new aromas is always important to the multibillion-dollar-a-year flavors and fragrances business, which is why International Flavors and Fragrances decided to team with the Wisconsin Center for Space Automation and Robotics (WCSAR) again to conduct another novel experiment on the STS-107 mission.



This research will investigate how microgravity might affect the formation of the volatile chemical compounds – the essential oils – produced by two different types of living flowers. The flowers will be cultured in the ASTROCULTURE™ plant chamber, which provides an enclosed and controlled environment.

As the flowers bloom in space, they will produce essential oils, and these volatile compounds will be collected using International Flavors and Fragrance's proprietary Solid Phase Micro Extraction (SPME) technology. They will be preserved using WCSAR-developed technology. After they are returned to Earth, the Micro Extraction devices will be sent to International Flavors and Fragrance's analytical laboratory for constituent and structural analysis.

The gene transfer experiment examines a newly developed transformation system to see if it operates efficiently in the microgravity environment. This research is important for the development of genetically engineered crops, also known as transgenic crops. It also is useful for producing valuable proteins.

On a prior flight, scientists used bacteria to transfer a gene carrying a desirable trait to soybean seedlings. The traits are inherited by subsequent generations of plants. On Earth, the expected transformation event for soybeans is at best 1 plant in 1,000 or 0.1 percent.

Previous commercial research on STS-95 and STS-101 has shown that *agrobacterium*-based transformation system greatly improved the transformation events or efficiency in microgravity. The increased effectiveness is partially because microbes, such as bacteria used to transfer the desired traits, thrive in microgravity.

This experiment, again sponsored by Producers' Natural Processing Corp. in West Laffeyatt, Ind., will demonstrate the effectiveness of a refined *agrobacterium*-based transformation system using wheat microspores as target material.

Experiment Operations

Both the ASTROCULTURE™ glovebox and the ASTROCULTURE™ plant growth unit were developed by one of NASA's 17 Commercial Space Centers – the Wisconsin Center for Space Automation and Robotics at the University of Wisconsin-Madison. This center specializes in the development of controlled environment technologies/facilities and agri-biotech research, and has conducted eight experiments on the space shuttle and two experiments on board the International Space Station.

Applications

The food industry and the flavors and fragrances industry are multibillion-dollar businesses. Fields that benefit from this type of research include:

- Agriculture



- Personal Care
- Fragrances
- Biotechnology

More information on the ASTROCULTURE™ experiment and other STS-107 experiments is available at:

<http://wcsar.engr.wisc.edu/>
<http://spaceresearch.nasa.gov/>
<http://www.scipoc.msfc.nasa.gov/>
www.spaceflight.nasa.gov
www.spd.nasa.gov
www.commercial.nasa.gov



Commercial Instrumentation Technology Associates Inc. Biomedical Experiments Payload (CIBX-2)

Experiment Name: Commercial Instrumentation Technology Associates Inc. Biomedical Experiments Payload (CIBX-2)

Mission: STS-107

Experiment Location: SPACEHAB Module

Commercial Space Company: Instrumentation Technology Associates Inc. (ITA), Exton, Penn.

Project Scientists: Dr. Dennis Morrison, NASA Johnson Space Center, Houston, Texas; Dr. Allen Edmundson, Oklahoma Medical Research Foundation, Oklahoma City, Okla.

Commercial Manager: Keith Robinson, NASA Marshall Space Flight Center, Huntsville, Ala.

Overview

Experiments to find solutions for a range of biomedical issues are being hosted by the Commercial Instrumentation Technology Associates Inc. (ITA) Biomedical Experiments (CIBX-2) payload. This research encompasses more than 20 separate experiments including cancer research, commercial experiments and hands-on student experiments from 10 schools as part of ITA's ongoing University Among the Stars program.

Protein crystal growth experiments will address the structure of urokinase – a protein that has been identified as a key enzyme in the spread of brain, lung, colon, prostate and breast cancers. Crystals of Bence Jones, a protein associated with bone cancer, will also be grown. Understanding their structures may help scientists develop treatments.

In a related area, the Microencapsulation of Drugs (MEPS) is an anti-cancer drug delivery system, based on a 10-year partnership with NASA's Johnson Space Center. On this mission, the co-encapsulation of antibodies and immune stimulants will be made in sub-micron microcapsules to target pulmonary and bacterial infections.



Other investigations include:

- Regeneration of Nerve-cell Growth Factor in Micro-g, Biospace Group and Oakwood College, both in Huntsville, Ala.
- Biofilm Formation, Southwest Texas State University, San Marcos, Texas
- Effect of Zero-G on Bacteria and Crystal Growth Experiments, Milton Academy, Milton, Mass.
- EdVenture Lab Crystal Growth Experiments, The Challenger Center, Alexandria, Va.
- Student Crystal Growth Experiments (Elementary Students), Lockheed Martin, Houston, Texas
- Muscle Cell Gene Expression, Brown University, Providence, R.I.

More than 3,000 students and 50 teachers have participated in Iota's University Among the Stars. This will be the seventh shuttle mission carrying ITA student experiments.

Flight History

ITA has provided low-cost multi-user space hardware for 19 missions on the space shuttle, the Russian space station Mir and sounding rockets. The STS-107 mission uses hardware that was flown in 1998 on STS-95 as CIBX-1.

An STS-95 experiment produced a large crystal of the Bence Jones protein that showed details of the protein's structure. This helped scientists identify the active site on the protein related to its painful disposition in the tissues of bone cancer patients. Now, scientists are producing better crystals on Earth for mapping analysis and to find ways to block the active site that causes the excruciating pain of bone cancer. These results are typical of the commercial, proprietary results obtained by ITA and its partners.

Experiment Operations

Two sets of equipment, the Dual-Materials Dispersion Apparatus (DMDA) and the Liquids Mixing Apparatus (LMA) are used. The DMDA is a multi-user space-processing laboratory. It accommodates microgravity experiments in cell biology, thin film membrane casting, macromolecular and inorganic crystal growth, seed germination, collagen research, fluid sciences, diffusion experiments, microencapsulation of drugs, and other biomedical and technical disciplines.



The LMA is a manually operated system that holds larger volumes per sample than the DMDA. It is used to mix two or three liquids or biomaterials in microgravity at predetermined times.

Applications

These experiments have a variety of biomedical applications.

For more information on this experiment and other STS-107 experiments visit:

<http://www.itaspace.com>
<http://www.spaceoutreach.com>
<http://spaceresearch.nasa.gov/>
www.scipoc.msfc.nasa.gov
www.spaceflight.nasa.gov
www.spd.nasa.gov
www.commercial.nasa.gov



Commercial Protein Crystal Growth – Protein Crystallization Facility (CPCG-H)

Experiment Name: Commercial Protein Crystal Growth – Protein Crystallization Facility (CPCG-H)

Mission: STS-107

Experiment Location: SPACEHAB Module

Commercial Space Center: Center for Biophysical Science and Engineering, University of Alabama at Birmingham

Commercial Space Center Director: Lawrence J. DeLucas, O.D., Ph.D.

Commercial Space Center Manager: John West, NASA Marshall Space Flight Center, Huntsville, Ala.

Overview

Within the human body, there are thousands of different proteins that serve a variety of different functions, such as making it possible for red blood cells to carry oxygen in our bodies. Yet proteins can also be involved in diseases.

Each protein has a particular chemical structure, which means it has a unique shape. It is this three-dimensional shape that allows each protein to do its job by interacting with chemicals or binding with other proteins. If researchers can determine the shape, or shapes, of a protein, they can learn how it works.

This information can then be used by the pharmaceutical industry to develop new drugs or improve the way medications work. The NASA Commercial Space Center sponsoring this experiment – the Center for Biophysical Sciences and Engineering at the University of Alabama at Birmingham – has more than 60 industry and academic partners who grow protein crystals and use the information in drug design projects.

Experiment Operations

While there are several ways to determine the structure of proteins, the most widely used method is protein crystallography. Just as water evaporates from a sugar solution to form sugar crystals, protein crystals will form in a solution that contains water. For this flight, numerous samples are processed in the Protein Crystallization Facility, which supports large-scale protein crystal growth.



When the crystals are returned to Earth, scientists can study them using X-ray diffraction. Scientists send a beam of X-rays through the crystals and measure how the X-rays are bent by the atoms of the crystal.

By studying the pattern made by the X-rays, they can then map the locations of the different atoms, allowing them to create a diagram of the protein's structure. With this as a guide, researchers can determine how the protein does its job.

Once this is known, researchers can find ways to help or hinder a given protein by designing pharmaceutical compounds that fit the protein like a key in a lock. Because the drug is targeted at a specific protein, less of the drug may be necessary. The drug may be more effective because it reacts only with a specific protein. There may be few, if any, side effects, which are caused when drugs react with other compounds in the body.

Flight History

Protein crystal growth experiments began flying on the space shuttle in 1985. Today, more than 40 protein crystal payloads have flown, producing diffraction-quality crystals of many proteins.

Applications

Structural studies of microgravity-grown crystals have provided information for the development of new drugs. For example, studies conducted by Dr. Lawrence DeLucas on crystals grown on shuttle flights have been used in the design of inhibitors, which may serve as broad-spectrum antibiotics.

More information on this experiment and other STS-107 experiments is available at:

<http://www.cbse.uab.edu/>
<http://spaceresearch.nasa.gov/>
www.scipoc.msfc.nasa.gov
www.spaceflight.nasa.gov
www.spd.nasa.gov
www.commercial.nasa.gov



Water Mist Fire Suppression Experiment (MIST)

Experiment Name: Water Mist Fire Suppression Experiment (MIST)

Mission: STS-107

Experiment Location: In NASA's Combustion Module-2 inside the SPACEHAB Module

Commercial Space Center: The Center for Commercial Applications of Combustion in Space (CCACS), Colorado School of Mines, Golden, Colo.

Commercial Space Center Director: Dr. F.D. Schowengerdt

Project Scientists: J. Thomas McKinnon, Angel Abbud-Madrid and Edward P. Riedel -- all of CCACS

Industry Partners: Environmental Engineering Concepts Inc., Palm Springs, Calif., and Arizona Mist Inc., Gilbert, Ariz.

Commercial Space Center Manager: Jeneene Sams, NASA Marshall Space Flight Center, Huntsville, Ala.

Overview

Researchers are going to space to study how a water mist system puts out flames. The research is aimed at developing a commercially viable, water-based fire-fighting system.

This system could replace the current fire-fighting chemicals including Halons, which are being banned because they damage Earth's ozone layer. This ban makes water, once again, the prime tool for fighting fire, since no other replacements have been found.

How do you put out fires with water and still reduce or eliminate property damage? Fine water mists may be the answer on Earth as well as in the air on commercial and military planes and even on spacecraft.

The STS-107 experiment that studies fine water mist fire suppression is sponsored by two companies -- MicroCool, in Palm Springs, Calif., and Arizona Mist Inc., in Gilbert, Ariz. They are working with the Center for the Commercial Applications of Combustion in Space (CCACS) -- one of NASA's 17 Commercial Space Centers that help industry conduct space experiments.

Space may be the ideal place to examine how water interacts with flame. On Earth, gravity causes lighter, hotter air to rise -- creating air currents that make it difficult to study the combustion process and fire-fighting techniques.



In microgravity -- the low-gravity environment created as the space shuttle orbits Earth -- these currents are reduced or eliminated. This allows scientists to study exactly what happens in the combustion process. For this experiment, scientists will observe how water droplets, like those in a fine fog, interact with a flame and extinguish it.

These observations will help industry determine the optimum water concentration and water droplet size needed to suppress fires. The information can be used to improve models for designing the next generation of environmentally friendly, low-cost fire-fighting systems.

Flight History/Background

This is the first spaceflight for the experiment, but the companies and CCACS have conducted extensive ground-based research, as well as research in drop towers and NASA's KC-135 aircraft, which both expose experiments to microgravity for brief periods.

Research conducted at the Arvada Fire Training and Research Center in Arvada, Colo., demonstrated that the ultra-fine misting heads developed by Environmental Engineering Concepts produced fine mists that were extremely effective in fighting common fires. Tests showed that mists used significantly less water to put out fires than larger water droplets produced by conventional sprinkler systems.

Experiment Operations

The Water Mist experiment studies how different sizes and concentrations of droplets affect a thin layer of flame, known as a laminar flame. The water droplets will be between 20 to 40 microns in size, as opposed to droplets from conventional sprinklers that are larger than 1 millimeter.

The flame will be produced by igniting a mixture of propane and air inside a transparent tube in the Combustion Module-2 (CM-2).

The Combustion Module, which has flown on several shuttle flights, was developed by NASA's Glenn Research Center in Cleveland, Ohio. It enables safe combustion research in space and is the forerunner for a similar facility being designed for the International Space Station.

Future water mist investigations on the space station can be larger and more complex, enabling companies to test different water injection systems, droplet sizes, and other fire scenarios.



Applications

With halon replacements expected to become an increasingly large part of the \$2 billion-a-year fire suppression industry, this experiment is of great commercial interest to the fire fighting industry.

- Ships (machinery spaces)
- Aircraft (passenger cabin and cargo)
- Spacecraft
- Libraries, museums
- Telecommunications racks
- Commercial cooking areas.

More information on the Water Mist experiment and other STS-107 experiments is available at:

<http://www.mines.edu/research/ccacs/>

<http://spaceresearch.nasa.gov/>

www.scipoc.msfc.nasa.gov

www.spaceflight.nasa.gov

www.spd.nasa.gov

www.commercial.nasa.gov



Zeolite Crystal Growth

Experiment Name: Zeolite Crystal Growth

Mission: STS-107

Experiment Location: SPACEHAB Module

Commercial Space Center: Center for Advanced Microgravity Materials Processing (CAMMP) at Northeastern University, Boston, Mass.

Commercial Space Center Director: Dr. Al Sacco

Commercial Space Center Manager: Jeneene Sams, NASA Marshall Space Flight Center, Huntsville, Ala.

Overview

Zeolites are as hard as rocks but work like sponges. They have a rigid crystalline structure with a network of interconnected tunnels and cages, similar to honeycomb. These tunnels can store chemicals, like fuels, and then release them when the zeolites are heated.

The Center for Advanced Microgravity Materials Processing (CAMMP) – one of 17 NASA-sponsored Commercial Space Centers – is working to improve zeolite materials for storing hydrogen fuel. The center is also applying zeolite research to detergents, optical cables, gas and vapor detection for environmental monitoring and control, and chemical production techniques that significantly reduce hazardous by-products.

Experiment Operations

A large part of CAMMP's research depends on figuring out the molecular structure of zeolites. Because the molecules are extremely small (2 to 8 microns), it is difficult to get accurate structural information about zeolites. Such information can be obtained, if zeolites can be grown 200 to 1,000 times their normal size. Through prior space experiments, CAMMP has discovered that it is possible to grow such large crystals in the microgravity conditions on the space shuttle.

STS-107 research will use new and improved hardware developed and also being used on the International Space Station. The hardware consists of sample tubes that hold the components that form zeolites, and a furnace unit used to process samples.



Operations will begin with the crew using a cordless screwdriver to mix the component elements in the sample tubes together. The mixing protocol will vary with each sample so that researchers can gain a better understanding of the nucleation process – the beginning of crystal formation -- and how to control it.

Once mixing is complete, the samples will be placed in the furnace for automated processing. Scientists will analyze the samples after they are returned to Earth. Data from the shuttle experiment can also help scientists select the best types of samples for long-term processing in the zeolite furnace, now being operated on the International Space Station.

When enough is known about these materials to manipulate both the nucleation and the growth, CAMMP can custom design them for specific applications, such as hydrogen fuel storage.

Applications

Zeolites could help us move from an economy that relies on petroleum to one that uses hydrogen for its fuel. Hydrogen would be infinitely renewable, pollution-free fuel. It is the most abundant element in the universe, and the main product of hydrogen combustion is water. One of the major problems to be solved is the efficient storage of hydrogen, but zeolite and zeo-type materials are being tested as a possible storage medium.

Since chemical processing is a trillion-dollar industry worldwide, any improvement in understanding zeolites could have an enormous economic impact.

More information on this experiment and other STS-107 experiments is available at:

<http://www.dac.neu.edu/cammp/>
<http://spaceresearch.nasa.gov/>
www.scipoc.msfc.nasa.gov
www.spaceflight.nasa.gov
www.spd.nasa.gov
www.commercial.nasa.gov



Low Power Transceiver

One of the FREESTAR experiments, the Low Power Transceiver (LPT) experiment is a low-power, lightweight software programmable transceiver prototype technology demonstration that is being developed by NASA as a low-cost S-band spacecraft navigation and communication device.

The LPT prototype receives Global Positioning System (GPS) satellite signals for spacecraft navigation support and provides both forward and return, low-rate data communications links to the Merritt Island (MILA) and Dryden Flight Research Facility (DFRC) ground stations and to the Tracking and Data Relay Satellite System (TDRSS). The experiment is designed to demonstrate the system's ability to do simultaneous communications and navigation, as well as multi-mode communications and reconfiguration. LPT is managed by NASA's Goddard Space Flight Center and sponsored by NASA/HQ Code M.

The LPT experiment consists of one thermally conductive box containing the electronics stack, three S-band antennas and one L-band antenna. The LPT payload uses general Orbiter services, including power control, command, and telemetry provided through the HHC avionics. On-orbit, the LPT payload will be primarily operated via direct communications between LPT and ground stations (MILA, WLPS, or DFRC) and/or TDRSS, with backup command and telemetry capability provided via the hitchhiker avionics and remote Payload Operations Control Center. During operations, LPT will utilize high S-band frequencies for communications.

The LPT TDRSS (and GN) forward link (uplink) frequency is 2106.40625 MHz and their TDRSS (and GN) return link (downlink) frequency is 2287.5 MHz (utilizing Left-handed Circular Polarization to work with the TDRSS MA system). Two standard switch panel switches will be utilized to prohibit inadvertent operation of the antenna. An additional inhibit will be provided through the HH avionics power relay to the LPT.

For more on this experiment see the section on FREESTAR experiments in this press kit.



Ram Burn Observations (RAMBO)

Ram Burn Observations (RAMBO) is a Department of Defense experiment that observes shuttle Orbital Maneuvering System engine burns for the purpose of improving plume models. On STS-107 the appropriate sensors will observe selected rendezvous and orbit adjust burns.



Vapor Compression Distillation Flight Experiment

Mission: Launch and return on STS-107

Experiment Location: SPACEHAB module double rack

Principal Investigator: Cindy F. Hutchens, NASA's Marshall Space Flight Center, Huntsville, Ala.

Overview:

One of the major requirements associated with operating the International Space Station is the transportation -- space shuttle and Russian Progress spacecraft launches -- necessary to re-supply station crews with food and water.

The Vapor Compression Distillation (VCD) Flight Experiment, managed by NASA's Marshall Space Flight Center in Huntsville, Ala., is a full-scale demonstration of technology being developed to recycle crewmember urine and wastewater aboard the International Space Station and thereby reduce the amount of water that must be re-supplied. Based on results of the VCD Flight Experiment, an operational urine processor will be installed in Node 3 of the space station in 2005.

Experiment Summary:

Vapor compression distillation systems mechanically mimic Earth's natural process of evaporation. Instead of heating water with the power of the Sun, however, these systems boil wastewater to produce and collect water vapor that is 97 percent free of minerals, chemicals and microbes. However, the boiling process relies on gravity-driven buoyancy and convection not present in the low gravity environment of the space station.

The VCD Flight Experiment is designed to verify the vapor compression distillation processing concept in "weightlessness," as well as the performance of the various components. Urine is processed using a "phase change" process -- from the liquid phase to the vapor phase and back to liquid. The heart of the experiment is the distillation assembly. To efficiently induce this phase change, the pressure inside this cylindrical distillation assembly is lowered to 0.7 pounds per square inch so that the boiling point where liquid turns to vapor is also lowered. For the VCD experiment, de-ionized water containing some salts will be used instead of urine. The water will be fed into the distillation assembly's rotating drum, spinning at 220 revolutions per minute, where it will form a thin film that will coat the walls of the drum. In the low-pressure environment, liquid will boil off at between 90 and 105 degrees Fahrenheit. The water vapor will be collected by a "de-mister" in the center of the drum and then fed into a compressor to raise the pressure slightly. It is then injected on to a thin wall around the outside of the drum where it condenses, transferring its



heat to another thin film of liquid inside the wall of the drum to continue the recycling process.

For the flight experiment, the process ends there. In actual operation aboard the station, however, after the brine – leftover solids and some liquid – reaches a high concentration, the brine and its tank are returned to Earth for cleaning and replaced with a clean tank, while the clean water will then be sent to a water processing assembly aboard the station. This assembly will further improve it before going into a clean water storage tank to be used for cleaning, cooking, drinking or other personal use aboard the station.

The VCD Flight Experiment is an intermediate risk mitigation step between the design of flight hardware and actual installation aboard the station.

Hardware/Operations:

The VCD Flight Experiment occupies a refrigerator-sized rack in the SPACEHAB module in the shuttle payload bay for the STS-107 mission. The key components are the distillation assembly, two pumps, wastewater storage feed tanks, air injection tank, a gas/liquid separator apparatus and a recycling filter tank. The crew will activate the experiment on flight day three of the mission. The first day of operations will be devoted mainly to pumping the air out of the distillation assembly to create a low pressure boiling environment without increasing the temperature. During the second, third and fourth days, the system will undergo a series of normal and abnormal operating scenarios, such as shutting down the processor at full speed and then starting it again.

The VCD Flight Experiment is largely automated, with the experiment team monitoring operations and receiving data in a control room at Johnson Space Center in Houston. The crew will be involved in setting up and activating the experiment for its six-hour run time each day. They are required to open and close air injection valves and collect water samples throughout the test period.

Background/Flight History

Experimental vapor compression distillation equipment and related Environmental Control and Life Support (ECLSS) hardware has undergone development at the Marshall Center since 1986. The Volatile Removal Assembly, including part of the station's water processor system, was tested on a SpaceHAB module on the STS-89 space shuttle mission in January 1998. Another VCD Flight Experiment was flown aboard a KC-135 aircraft in 2002 to simulate the microgravity conditions it would encounter aboard the shuttle. That hardware included a clear acrylic drum so that engineers could observe the fluid behavior.



Benefits

When installed on the space station, VCD technology will process about 4,400 pounds (2,000 kg) of water annually to support station crews. Human exploration beyond the Moon will require such recycling systems. The technology may also have applications on Earth, where many people do not have an abundant, reliable and affordable source of drinking water. As the human population surpasses 6.2 billion, water is becoming a precious commodity.



Exploring Heart and Lung Function in Space ARMS Experiments

The Advanced Respiratory Monitoring System (ARMS) is a suite of monitoring instruments and supplies used to study the heart, lungs, and metabolism. Many experiments sponsored by the European Space Agency (ESA) will be conducted using ARMS during STS-107.

The near-weightless environment of space causes the body to undergo many physiological adaptations, and the regulation of blood pressure is no exception. Astronauts also experience a decrease in blood volume as an adaptation to microgravity.



ARMS measurements are taken during exercise, with astronaut subject Mike Anderson, in a ground-based test of the equipment.

Reduced blood volume may not provide enough blood pressure to the head during entry or landing. As a result, astronauts often experience light-headedness, and sometimes even fainting, when they stand shortly after returning to Earth.

To help regulate blood pressure and heart rate, baroreceptors, sensors located in artery walls in the neck and near the heart, control blood pressure by sending information to the brain and ensuring blood flow to organs. These mechanisms work properly in Earth's gravity but must adapt in the microgravity environment of space. However, upon return to Earth during entry and landing, the cardiovascular system must readjust itself to gravity, which

can cause fluctuation in the control of blood pressure and heart rate. Although the system recovers in hours or days, these occurrences are not easily predicted or understood — a puzzle investigators will study with the ARMS equipment.

Earth Benefits and Applications

Studies with ARMS during STS-107 mean:

- Better understanding of the basic workings of the heart, lungs, and supporting systems
- Helping to develop new diagnostic tools for predicting illness and establishing rehabilitation techniques when problems do occur
- Applying rehabilitation techniques to treatment of patients confined to long-term bed rest.

In space, researchers can focus on aspects of the cardiovascular system normally masked by gravity. The STS-107 experiments using ARMS will provide data on how the heart and lungs function in space, as well as how the nervous system controls them. Exercise will also be combined with breath holding and straining (the Valsalva maneuver) to test how heart rate and blood pressure react to different stresses. This understanding will improve astronauts' cardiopulmonary function after return to Earth, and may well help Earthbound patients who experience similar effects after long-term bed rest.

Project Scientist: Dr. Andre Kuipers, European Space Agency
Project Manager: Michael Cork, European Space Agency
Operations Engineer: Marine LeGouic, European Space Agency

Background Information

Science

ARMS experiments will investigate pulmonary (lung), respiratory (airway), and cardiovascular (heart and blood vessels) changes during rest and exercise. ARMS instruments measure gas composition during inspiration and expiration, flow rate, mouthpiece pressure, heart rate, electrocardiogram (ECG), blood pressure, and respiratory rate — basic indications of how efficiently the lungs and heart are working. Astronauts undergo a range of health tests to make sure they are in peak physical condition before flight. Since preexisting health problems can be ruled out as a contributing factor, researchers can attribute changes to astronauts' cardiopulmonary systems to the effects caused by the space environment. Researchers use this information to create models that can be applied to future space travelers and humans on Earth.



The data and resulting insight from the continuing ARMS studies will help researchers develop rehabilitation techniques to treat patients confined to long-term bed rest.

Hardware

The ARMS equipment, which is designed for non-invasive research on the respiratory, pulmonary, and cardiovascular systems, consists of three modules in SPACEHAB. The equipment contains two multi-gas analyzers, a flow meter, and a valve system into which the astronauts breathe. This system measures and records pressure, flow, and gas concentration during different activities performed by the astronauts. The system also includes a blood pressure cuff, an ECG, and a respiratory inductance plethysmograph, a device used to measure breathing frequency.

Multi-gas analyzers are instruments that measure the gas concentrations in inhaled and exhaled gas, including gases not found in air used to probe various aspects of heart and lung function. Respiratory flow meters measure gas flow and volume. The astronauts breathe into the respiratory valve system, which includes a pressure sensor inside the mouthpiece/airway to record the pressures generated during the straining maneuver. A gas supply subsystem provides the special respiratory gas mixtures used for both calibration and certain breathing tests. ECG instrumentation for monitoring the astronaut's heart rate, and blood pressure instrumentation for measuring peripheral arterial blood pressure are part of the equipment. A special belt will record rib cage expansion during the test. Environmental conditions of temperature, pressure, and relative humidity will be recorded using the ambient conditions monitoring system.

Using specific tracer gases which will then be measured by the ARMS hardware, it is possible to determine the lung volume and amount of blood pumped by the heart, among other things. All measurements gathered for the experiments are recorded onto a laptop computer and later downloaded for study.

Operations

During flight, STS-107 astronauts take measurements while performing activities. They must follow strict procedures for ARMS measurements. The ARMS laptop computer contains detailed instructions on all experiment protocols including resting and exercise protocols, as well as special breathing patterns and other techniques the astronauts must perform.

Researchers track changes in the respiratory and cardiovascular systems using the data collected before, during, and after flight.

Earlier Studies

This flight furthers the ongoing study of heart and lung function from the European Space Agency's EUROMIR 95 mission and Spacelab.

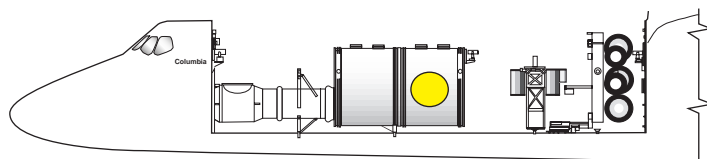

Approximate location of this payload aboard STS-107.



European Space Agency Payloads

Overview

Advanced Protein Crystallization Facility (APCF):

Objective: To grow large, well ordered crystals of different proteins and viruses for analysis and characterization using a crystallization facility. Operations are fully automated with minimal crew interaction.

Facility for Adsorption and Surface Tension (FAST):

Objective: To measure the response of surface tension to carefully controlled dynamic changes in the surface area of bubbles or droplets using a multi-user facility. Operations are fully automated with minimal crew interaction.

BIOPACK:

Fully automated, multi-user facility that provides capability to conduct biological experiments under varying gravity conditions using two standard facility containers. Facility includes an incubator with three centrifuges, a cooler and a freezer. Eight investigations are:

LEUKIN: Role of Interleukin-2 Receptor in signal transduction and gravisensing threshold in T-Lymphocytes.

REPAIR: Fidelity of DNA double-strand break repair in human cells under microgravity.

CONNECT: Function of the focal adhesion of plaque of connective tissue in microgravity.

BIOKIN-3: Determination of the space influence on bacterial growth kinetics.

YSTRES: Yeast cell stress under microgravity.

BONES: The role of bone cells in the response of skeletal tissues in microgravity.

STROMA: Bone marrow stromal cells differentiation and mesenchymal tissue reconstruction in microgravity.

BACTER: Bacterial physiology and virulence on Earth and microgravity.



BIOBOX:

Multi-user facility that hosts a variety of biological experiments with the overall goal of observing the effects of weightlessness on living systems. Operations are fully automated with the exception of facility activation and occasional filter cleaning. Four investigations are:

OBLAST: Comparative analysis of osteoblastic (bone-forming) cells at microgravity and 1G.

OCLAST: Microgravity effects on osteoclast (bone-removing) driven resorption in vitro.

OSTEOGENE: Identification of microgravity-related genes in osteoblastic cells.

RADCELLS: Biological dosimetry in space using haemopoetic stem cell functions.

For more on ESA experiments, see the SPACEHAB commercial experiments list in the SPACEHAB RDM section.



Fast Reaction Experiments Enabling Science, Technology, Applications and Research (FREESTAR)

Goddard Space Flight Center (GSFC) Wallops Flight Facility (WFF) manages NASA's Shuttle Small Payloads Project (SSPP). The SSPP designs, develops, tests, integrates and flies a group of small payload carrier systems for the space shuttle. These carriers - the Hitchhiker, Getaway Specials (GAS), and Space Experiment Module (SEM) - support payloads supplied by NASA, other U.S. government agencies, universities, high schools, domestic commercial customers, and foreign nationals and governments. These carriers can support payloads that range in size between 50 lbs. (23 kg) and 4,000 lbs. (2,270 kg).

Payload Description

The FREESTAR payload will include six separate experiments mounted on a crossbay support structure. The six experiments include:

- Mediterranean Israeli Dust Experiment (MEIDEX) - MEIDEX is managed by the Israeli Space Agency and Tel-Aviv University. NASA/HQ Office of Earth Science sponsors MEIDEX.
- Solar Constant Experiment-3 (SOLCON-3) – The SOLCON series is managed by the Royal Meteorological Institute of Belgium. The SOLCON experiment has previously flown on STS-85 and STS-95 as part of the International Extreme Ultraviolet Hitchhiker experiment and on the first Spacelab mission, the Eureca platform and on Atlas missions.
- Shuttle Ozone Limb Sounding Experiment-02 (SOLSE-02) - SOLSE is managed by NASA/GSFC Atmospheric Chemistry and Dynamics Branch. The SOLSE experiment has previously flown on STS-87. NASA/HQ Office of Earth Science sponsors the SOLSE experiments.
- Critical Viscosity of Xenon-2 (CVX-2) - CVX-2 is managed by NASA Research Center. The CVX experiment has previously flown on STS-85. The CVX experiment series is sponsored by NASA/HQ Office of Biological and Physical Research.
- Low Power Transceiver (LPT) is managed by NASA/GSFC Microwave Systems Branch. LPT is sponsored by NASA/HQ Office of Space Flight.
- Space Experiment Module (SEM) – SEM, which consists of 10 experiment modules, contains student experiments from U.S. grade schools. The SEM program is managed by the NASA/GSFC Shuttle Small Payloads Project Office.



MEIDEX Experiment Description

The primary mission of the Mediterranean Israeli Dust Experiment (MEIDEX) payload is to study the temporal and spatial distribution and physical properties of atmospheric desert dust over North Africa, the Mediterranean and the Atlantic Saharan regions. This aim is achieved by a remote sensing experiment operated by the astronauts aboard the space shuttle. In addition to the primary desert aerosol observations, MEIDEX will accomplish diverse secondary science objectives by performing slant visibility observations, sea-surface reflectivity observations, desert surface observations and observations of Transient Luminous Events, better known as sprites.

The MEIDEX experiment includes remote as well as in-situ measurements of light scattering by desert aerosol particles in six different wavelength intervals from the near Ultraviolet to the Solar Infrared. The wavelengths selected for space-borne remote measurements of desert aerosols include two wavelengths used by the Total Ozone Mapping Spectrometer instruments as well as four of those installed on the Moderate Resolution Imaging Spectroradiometer, an instrument aboard both NASA's Terra and Aqua spacecraft.

This facilitates the calibration of the TOMS-like information acquired by the instrument in the UV spectral region by that provided simultaneously by the MODIS-like bands on the same instrument. The MEIDEX scientific initiative will also incorporate supporting ground-based and airborne measurements in order to provide both optical observations and direct sampling. The airborne measurements will be planned so as to fly under or in the vicinity of the shuttle orbits.

MEIDEX Physical Description

- A Xybion IMC-201 radiometric camera equipped with six narrow-band filters centered at 340 nm, 380 nm, 470 nm, 555 nm, 660 nm, and 860 nm.
- The Xybion camera has a field of view of 10.7 x 14.0° with a nadir footprint (looking straight down) of 52 x 68 km.
- Second wide (60°) field of view video camera that operates as a viewfinder.
- Both cameras are mounted in a single-axis gimballed truss located in a standard Hitchhiker 5.0 cubic-foot canister equipped with a 5-inch extension and a Hitchhiker Motorized Door Assembly.
- The MEIDEX canister is also equipped with a 16-inch quartz window with a broadband anti-reflective coating. Other Hitchhiker equipment consists of two Hitchhiker Video Interface Units.



SOLCON-3

History/Background

To understand the influence of the Sun on climate changes on Earth, it is necessary to make long-term, accurate measurements of the solar constant, the amount of solar energy received per unit surface at a distance of one astronomical unit (the average distance of Earth's orbit) from the Sun. The SOLCON instrument is a reference instrument for the measurement of the solar constant. It is flown regularly during short periods on the space shuttle.

SOLCON-3 Experiment Description

The SOLCON instrument is designed to accurately measure the solar constant and identify variations in the value during a solar cycle. SOLCON measures the solar irradiance forms in space to avoid perturbations by the atmosphere of the Earth. It is also used as a reference to construct a long duration time series of the solar irradiance. This data will ensure continuity of the solar constant level obtained by instruments mounted on free flyers, over climate time scale duration. Solar measurements are performed by determining the power difference required to bring two cavities into thermal balance when one is open to the Sun and the other is closed. The SOLCON-3 payload utilizes general space shuttle services including power control, command, and telemetry provided through the Hitchhiker carrier avionics equipment.

SOLCON- 3 Physical Description

- Solcon-3 will be mounted on an HH Single Bay Pallet on top of the Hitchhiker Multipurpose Equipment Support Structure
- Solcon-3 consists of a radiometer and a digital processor unit covered by a thermal blanket to provide Passive Thermal Control
- The radiometer unit houses the Sun pointing monitor, shutter assembly, radiometer assembly and electronics
- The digital processor unit houses the experiment control and interface to the Hitchhiker avionics
- The radiometer unit consists of two channels through which solar radiation may be sensed
- Each channel contains a radiation sensor and has two apertures



- Independent shutters protect the first aperture of each channel. Each shutter seals out any solar radiation from the radiation sensor when closed and allows the sensor to receive solar radiation when open
- An opening and closing outer cover on the radiometer unit provides protection from contamination during non-operating periods

SOLSE-2

History/Background

The discovery of the ozone hole in 1985 demonstrated the very large changes in ozone that were occurring in the lower stratosphere near 20 km, instead of the upper stratosphere as first expected, and where current ozone instruments are focused. The Shuttle Ozone Limb Sounding Experiment (SOLSE-2) will show that more information is available by looking at ozone from the side, at Earth's limb or atmospheric boundary. Ozone monitoring should be focused in the lower stratosphere by measuring ozone from a tangential perspective that is centered at the limb, which provides ozone profiles concentrated in the lower stratosphere. Stratospheric ozone depletion is a global concern because the ozone layer there keeps 95 percent of the UV radiation from striking the Earth.

The first flight of the Shuttle Ozone Limb Sounding Experiment (SOLSE) proved that this technique achieves the accuracy and coverage of traditional measurements, and surpasses the altitude resolution and depth of retrieval. SOLSE demonstrated that vertical profiles of ozone could be measured with high resolution using solar ultraviolet scattering from the Earth's atmospheric limb.

SOLSE-2 Experiment Description

SOLSE is an imaging spectrometer designed to produce high quality 2-dimensional images of the limb in visible and UV light while minimizing internal stray light. As one of the experiments flying aboard the Hitchhiker payload, the principle mission of SOLSE-2 is to demonstrate a new technique to measure the vertical distribution of ozone in the atmosphere. The ozone layer near the tangent point strongly absorbs radiation at particular wavelengths of light. SOLSE infers the presence of ozone with high altitude resolution by measuring the relative absence of radiation at those wavelengths according to height.

Using a limb viewing geometry, SOLSE-2 will demonstrate the feasibility of measuring limb-scattered radiation to retrieve ozone with improved vertical resolution than a traditional nadir looking instrument can achieve. Second, SOLSE will demonstrate the feasibility of using Charged Coupled Device technology to eliminate moving parts, which could lead to simpler, cheaper, ozone mapping instruments. The shuttle provides the perfect testbed to demonstrate new technology and measurement techniques without committing the funds for flight instrument. Once proven over a wider range of viewing conditions, the SOLSE-2



technique will be used to routinely measure ozone by the next generation weather satellites.

SOLSE-2 Physical Description

- The instrumentation subsystem consists of a visible and UV spectrograph with a CCD array detector, photodiode array and visible light cameras, calibration lamp, optics and baffling
- The experiment is housed in a Hitchhiker canister with canister extension ring and equipped with an Hitchhiker Motorized Door Assembly
- The optical slit is masked with a linear attenuation filter that normalizes the intensity of the limb that varies by factor of 100 from top to bottom
- A shutter controls the exposure of each frame
- The filter wheel housing encloses 6 ion-assisted deposition filters at UV and visible wavelengths

CVX-2

History/Background

The Critical Viscosity of Xenon-1 Experiment first flew on STS-85 in 1997 as part of the Hitchhiker payload TAS-01. CVX revealed that when close to the liquid vapor critical point, xenon is partly elastic: it can “stretch” as well as flow. For STS-107, the hardware has been enhanced to determine if critical xenon is a shear thinning fluid. An understanding of shear thinning in a simple fluid will enable scientists to understand the phenomenon in more complex, industrially important fluids, such as: paints, emulsions, foams, polymer melts, pharmaceutical, food and cosmetic products.

CVX-2 Experiment Description

The Critical Viscosity of Xenon-2 Experiment will measure the viscous behavior of xenon - a heavy, inert gas used in flash lamps and ion rocket engines - at its critical point. The effects of gravity limit viscosity experiments on Earth. Xenon, near the critical point, will collapse under its own weight when exposed to Earth’s gravity, thereby increasing the density at the bottom. Experiments in the microgravity of orbit eliminate density differences and allow extended experiments to achieve the precision that scientists need.

Shear thinning occurs in complex fluids, such as paints and blood that become “thin” and flow easily under a shear stress such as stirring or pumping. CVX-2 will be the first experiment to examine the shear-thinning phenomenon in a simple fluid.



CVX-2 Physical Description

- Viscometer comprised of a nickel screen that vibrates between two pairs of brass electrodes in a xenon bath
- The grid is 7x 19 mm (0.28 x 0.74 in) and weighs less than 1 mg.
- An electrode is positioned 4 mm (0.16 in) to each side of the screen
- An electrical charge is applied by the electrodes that will oscillate the screen
- The electrodes then measure the screen's displacement
- The sample cell is a copper cylinder, 62 mm long by 38 mm wide (2.45 x 1.5 in), that conducts heat and adds thermal inertia to ensure slow, even changes in temperature
- The cell is enclosed in a three-layer thermostat to improve thermal control
- CVX-2 is contained in two Hitchhiker canisters mounted on the Multi-Purpose Equipment Support Structure
- One canister houses the Experiment Package. The second canister houses the Avionics Package which includes the data acquisition and control electronics, and the power conditioning systems
- The experiment plan involves four "sweeps." That is, the temperature will be gently moved up and down while the screen oscillates and data are continuously recorded

LPT

History/ Background

The paradigm of spacecraft design is changing throughout the space industry. Designs are requiring smaller, cheaper, and more capable systems. A key technology component that will enable these types of designs is a small, highly integrated, reprogrammable, multi-purpose communications and navigation payload that can withstand the radiation environments encountered over a variety of orbits.

LPT Experiment Description

The Low Power Transceiver (LPT) is a compact, flexible device that can be configured to perform custom communications and navigation functions in terrestrial, airborne, and space applications. The LPT is a collection of interchangeable hardware modules that form a software programmable platform for a variety of communication and navigation applications. The LPT can simultaneously process multiple radio frequencies (RF bands) in



the transmittance or retrieval direction, and simultaneously process multiple data channels within each RF band; further, its modular architecture provides a flexible arrangement of signal processing resources. This technology thrust strives to return the maximum possible scientific information from instruments on board a spacecraft to the customer/principal investigator on Earth. GSFC engineers are working rapidly to prototype and demonstrate applicable Internet technologies and methodologies and to infuse them into flight missions where they will significantly reduce development costs and greatly increase mission flexibility. Furthermore, they expect these technologies to enable entirely new, distributed, system and mission models in the future.

LPT Physical Description

- One thermally conductive box containing the LPT electronics stack.
- The LPT experiment will be mounted on two HH Single Bay Pallets, one of which is shared with SOLCON-3, on top of the HH MPESS.
- LPT has been integrated with a commercial processor board functioning as the flight computer, along with an three S-Band Receive Antenna, and one L-Band Antenna or Low Gain Transmit Antenna, all mounted to the top of the HH Multi-purpose Equipment Support Structure (MPESS) via a HH Single Bay Pallet (SBP).
- The flight computer will use GPS-Enhanced Orbit Navigation System (GEONS) software to process the Global Positioning System (GPS) data.
- The flight computer will run the Linux operating system, and use Mobile IP over all of the RF links.
- The LPT TDRSS (and GN) forward link frequency is 2106.40625 MHz and the TDRSS (and GN) return link frequency is 2287.5 MHz.
- Two Standard Switch Panel (SSP) switches will be incorporated to prohibit inadvertent Radio Frequency (RF) transmission from the antenna.

SEM- 14 Experiments

Does Popcorn Pop the Same After Being in Space?

Does a crystal grow the same in space as it does on Earth?

Does heat transfer any differently in zero gravity?

Now there's a way for students to answer questions like these. NASA has developed an educational program for kids who want to discover more about space by building



experiments that may ultimately fly on a space shuttle. The program is called the Space Experiment Module or SEM.

SEM is open to U.S. students in grades K-12 and university level. Grades 9-12 may also apply through the NASA Student Involvement Program (NSIP), which is an annual national competition.

Through SEM, kids will learn all about putting a scientific experiment into space. With the help of a teacher or mentor, students will create, design and build an experiment that is their own. The SEM program focuses on the science of zero gravity and microgravity.

Selected student experiments are flown in NASA provided modules. The SEM carrier system accommodates 10 modules in a standard Get Away Special canister that mounts in the cargo bay of the space shuttle. Experiments are qualified for the program through a flight certification process that includes an experiment proposal review and a Customer Agreement. There is no cost for student experiments to fly in the program.

For more information on grades 9-12 NSIP competition visit:

<http://www.nsip.net/index.cfm>

International students interested in SEM should contact the SEM mission manager:

Charles.L.Brodell.1@gsfc.nasa.gov

“Garden from the Stars” - Central Park Middle School, Schenectady City School District, and Farnsworth Middle School, Guilderland Central School District, Guilderland, N.Y.

The experiment involves sending selected seeds, representative of wildflowers from the ecologically unique and sensitive land area of the Albany Pine Bush Preserve, into space to measure effects of spaceflight and zero gravity on growth of plants. It is hypothesized that there will be measurable differences in growth of plants from “space” seeds compared with plants grown from “nonspace” control seeds. These differences may include germination period, size of plant, number of petals, shape of leaves, and color variations. Plants grown from the “space” seeds will be donated to the City of Schenectady’s Central Park Gardens and some will be returned to the Pine Bush to help in restoration of the native plant population.



“United Voyager, Moving and Shaking at M.S. 135 & M.S. 143” - Frank D. Whalen Middle School and Peter Tetard Middle School, New York, N.Y.

Students from Frank D. Whalen Middle School & Peter Tetard Middle School in New York City will partner in this experiment. They will be investigating cosmic radiation, g-forces of space travel, and effects of space travel on plant growth patterns. The plant growth investigation will use tomato seeds (native to the Bronx) along with soil samples. Other sample materials will include chalk, marbles, gum, gum/taffy, iron filings, small magnets, candles, crayons, film, yeast, and a pendulum watch. Control groups will be maintained on Earth and used to determine the changes caused by the spaceflight.

“Wearable Radiation Protection” - The Mott Hall-CCNY STARS Program, the Mott Hall School-IS223 & The City College of New York, New York, N.Y.

Living and non-living things that travel outside of the Earth’s atmosphere and the Earth’s magnetic field will be subjected to levels of radiation that are higher than those to which they are exposed on the surface of the Earth. This experiment tests the effectiveness of various flexible materials as a barrier to this radiation. Natural and synthetic fabrics made of organic and inorganic materials will be wrapped around dosimeters that measure exposure to radiation. It will then be possible to see if any of the tested materials provide a significant amount of protection against radiation when worn. The students in the SEM team are participating in a program called the Mott Hall-CCNY STARS (Student Apprenticeships in Research). STARS is a partnership between the City College of New York and The Mott Hall School. Each year eighth-graders spend three hours a week working with mentors in CCNY science and engineering research laboratories. The goal of STARS is to empower and encourage minority students to pursue careers in science and engineering. The Mott Hall School - IS 223 is a public school in Community School District 6 in the North Harlem/Washington Heights neighborhood of New York City. It is a grade 4-8 magnet school for 450 students offering advanced studies in math, science and technology. Most of the students, 85 percent of the student population, are first- or second- generation immigrants from Latin America, especially the Dominican Republic. About 10 percent are African Americans. The others are almost all immigrants from other countries.

“NYC KISS (Kids Investigations in Space Science)” - American Museum of Natural History, Rose Center for Earth and Space, New York, N.Y.

The NYC KISS program consists of the Rose Center for Earth and Space, part of the American Museum of Natural History, working in conjunction with six New York City educators to introduce hundreds of New York City schoolchildren to space and the hazards and beauties that it holds. Experiments will determine how the space environment will change a variety samples. Experiment samples will include DNA samples, composting materials, magnets, film, sunscreen, and other passive material samples.



“VIRUS- T4” - Bishop Borgess High School & Academy, Redford, Mich.

Students will study two different aspects of the effect of the Near-Earth Space Environment (NESE) on biological materials. In one experiment, they will study the degradation of antibiotic activity in NESE compared to control (terrestrial) samples. They will perform standard Kyrby-Bauer antibiotic sensitivity tests on the NESE and terrestrial samples of various antibiotics. The second experiment will measure the viability of the T4 Virus samples exposed to the NESE (X-rays and Gamma Rays) and compare that to the viability of terrestrial samples.

A radiation dosimetry badge will be enclosed in the module for measuring radiation exposure. Students will perform a standard dilution plaque assay on both the space and terrestrial samples, under the direction of a trained microbiologist. Students will learn experimental design and data interpretation, and will calculate antibiotic and virus viability using their math skills. They will also study the effects of radiation on fluorescent dyes to determine if they will glow brighter after exposure to the NESE. The students will communicate their results in a written report, in which data will be presented in tabular and graphic forms. This will also include a brief oral presentation.

“OGRE” - Ogdensburg Public School, K-8, Ogdensburg, N.J.

Students at the Ogdensburg School are preparing an experiment that will test the affects of radiation and weightlessness on florescent minerals. Ogdensburg is famous for its Sterling Hill Mine where there is an abundance of florescent minerals. These minerals have been displayed in the Smithsonian Institute in Washington, D.C., the Museum of Natural History in New York and other museums around the world. Students will be collecting mineral samples and dividing them into a control group, which will stay on Earth, and an experimental group, that will fly in the space shuttle. They will photograph both groups of minerals under ultraviolet light, so they can compare their luminescence once the minerals return from space. Mineral spectrographs will be taken before and after flight using the Cary Variance Florescent Mineral Spectrophotometer at Varian technologies. The mass of the minerals will also be measured to see if any changes occur from the space environment.

“Worms & Mold in Space” - East Norriton Middle School, Norristown, Pa.

The first part of this experiment addresses food preservation as it's affected by zero gravity and above normal levels of radiation. Five samples of bread will be sent into space while five identical samples will be maintained on Earth for control purposes. Examination and comparison of variables and controls will hopefully show if zero gravity and radiation had any effects on bread mold growth and life activities. Data will then possibly be applied to future NASA missions. The second part of the experiment will investigate mealworms. Mealworms are popular sources of food for reptilian pets and they also go through a metamorphosis. Their food and oxygen requirements are minimal. The hope is that the samples will survive the trip and return to Earth for comparison with the earthbound control group. Mutations and compatibility with populations left on Earth will be examined.



“C.D. in Space?” - Country Centre 4-H Space Science Project, Sacramento, Calif.

“CD in Space” is an extension of the Country Centre 4-H Space Science “A Seed for Larger Service” project. This hands-on 4-H space science project encourages experiencing math, science, scientific research and the scientific process in an after school setting.

The experiment team is comprised of one 4-H space science project leader and 14 youth ranging between the ages of 5 and 16 who reside in Sacramento County. Other individuals involved include professionals in the greater community to consult and aid in the experiment process. The purpose of this experiment is to test how radiation, vibration and temperature extremes in the space environment might affect a compact disc. A control group of CDs will remain on Earth and, using technology and scientific methods of analysis, the youths will compare the control group with the flight group.

“How Do Our Space Beans Grow?” - J.M. Bailey School Kindergarten, Bayonne, N.J.

The kindergarten students at John M. Bailey School in Bayonne, N.J., will send bean seeds into space. This experiment will be done in conjunction with the life science curriculum “PLANTS -Seeds and Plant Growth.” Children will discover if a change in environment will affect the growth rate of seeds. Will seeds kept in the dark germinate? Will it make a difference if they are in air, sand, soil or water? After seeds return from space, they will be planted along with a control group of seeds kept on Earth. Both sets of seeds will be monitored for rate of growth. Children will compare the development of buds, flowers and leaves. Math skills will be incorporated through measuring and graphing plant growth. Children will keep a journal to record observations and data during the project.

“St. John’s Seeds” - St. John the Baptist Preschool, New Freedom, Pa.

The experiment will investigate how the space environment will affect tomato seeds. The students suspect that the seeds will grow “funny” on their return. The students will get to see first-hand the effects of space travel. The group will be connecting this experiment to units on spring and the life cycle of the seed.

“Natural Space Art (NSA)” - Shoshone-Bannack High School, Fort Hall, Idaho

Students and staff at the Shoshone-Bannock High School located on the Fort Hall Indian Reservation at Fort Hall, Idaho, are planning an experiment that will investigate if urine-filtered water will mix with paint dyes. The team will be building on past space science projects and experiments. The team will fly the mixtures to see how they react in space. Students and staff will also paint small objects like canvas, wood, rocks, and metal with the mixtures and see how they survive the extreme temperatures of space. The team will run a control in the lab and compare results. Some of the questions to be investigated include: Will the rigors of spaceflight affect the painted materials? Will solutions of urine, water and dyes be usable once returned back from space? Could astronauts use filtered urine water for art purposes in space?



National Space Development Agency of Japan (NASDA) Space Experiment Project

Mission Overview

The National Space Development Agency of Japan (NASDA) will implement protein crystal growth experiments for about 16 days on space shuttle mission STS-107 prior to actual utilization of the Japanese Experiment Module (JEM) "KIBO." Biological fundamental research experiments and experiments on medical applied research for pharmaceuticals will be conducted with the Commercial Macromolecular Protein Crystal Growth (CMPCG) equipment. NASDA is also providing an opportunity for a space education program in protein crystal growth for high school students.

In addition, the Biospecimen Sharing Program (BSP) will clarify the effects of space on living organisms using rodents carried aboard the space shuttle in the Animal Enclosure Module (AEM).

The experiments using the space environment will produce significant results for protein research and the BSP.

Significance of Protein Research

Today we recognize numerous growing threats to human bodies including aging, viruses, various diseases, and chemical substances such as environmental hormones, which are strongly related to various functions of proteins, important components of living organisms. The functions of proteins heavily depend on their three-dimensional structure. Clarifying the protein's functions and its structure at the atomic level will contribute to research in bioscience and medicine.

Decoding of the human genome was almost completed in June 2000, and analyses of protein functions and structures have received much attention as post-genome-sequence research. Structure-Based Drug Design (SBDD), which applied the protein research in a medical development for disease treatment, has attracted many pharmaceutical companies.

Protein Crystallization in Space

High-quality single-protein crystals suitable for research are essential for highly detailed protein structure analysis by X-ray diffraction, the instrument used for determining the 3-dimensional structure of macromolecules. On Earth, gravity causes crystal sedimentation and convection, which affect the quality of crystals. The microgravity environment of space has been used to grow high-quality crystals; however, there are still more challenges to growing high-quality crystals with high probability. Hence



experiments in space must be conducted continuously to clarify the crystallization process.

Protein crystal growth experiments will be performed to clarify functions of various biologically important proteins and differences between proteins crystallized in space and on the Earth. High-quality crystals produced in space provide a better understanding of the relation between protein functions and structures and of conditions necessary for growing crystals of high quality. Science research themes are: study of the relationship between crystallization condition and crystal quality for Cytochrome; high-quality GCS crystal growth in microgravity; high-quality NfsB crystal growth in microgravity; crystallization of high-quality Congerin and Congerin mutants in microgravity; and crystallization of complex protein crystals in microgravity.

Applied research themes for the STS-107 experiments are: applied research on protein crystallization in space for designing anti-inflammatory and anti-somnolent drugs; molecular design of novel drugs for parasitic diseases based on the crystal structure; drug discovery study for specific inhibitor of geriatric diseases; and studies on crystallization of a photoreceptor protein.

NASDA is developing common and basic techniques leading to success for space experiments. Such techniques would enable the prediction of optimum experimental conditions in space from the results of ground experiments. Protein crystal growth experiments will be performed to verify the developed optimal techniques for microgravity experiments using vapor diffusion.

NASDA will also provide an opportunity for high school students to conduct protein crystal growth experiments using CMPCG aboard the space shuttle. Students will learn the significance of research on proteins and microgravity by conducting preparative and space experiments and writing papers on their analyses.

Animal Research

The International Space Station will be assembled at the beginning of the 21st Century. The advance of humans into space will then have finally started in earnest. It is essential to perform animal studies using mammals, such as rodents, to ensure safe human space activities. Detailed analysis of the effects of the space environment on mammalian physiology is very important from the life science and medical viewpoints.



Biospecimen Sharing Program (BSP)

Rodent experiments will be performed to clarify functions of various biologically significant differences between space and Earth environments. Nine experiments in the following four scientific fields will be performed on STS-107 by Japanese principal investigators. The four fields are bone and muscle, metabolism and endocrinology, neural system and radiation biology. The nine experiments are:

- Effects of spaceflight on the gene expression of skeletal muscle in rats
- Effects of spaceflight on the characteristics of fast and slow hindlimb muscles of rats
- Osteoactivin: A novel glycoprotein inhibiting adhesion of osteoblastic cells to bone matrix
- Analysis of gene and protein expressions of cytochrome P450 and stress-associated molecules in rat livers after spaceflight
- The effects of microgravity on mRNA expression in the vestibular endorgans
- Effect of space environment on the metabolism of nicotinamide adenine dinucleotide (NAD) metabolism in rats
- Gene expression of p53-regulated gene after exposure to space environment in rat
- Effects of spaceflight on spermatogenesis in rat-expression and quantification factors implicated spermatogenesis
- Effects of microgravity on the fiber component of the aortic depressor nerve in the Fisher 344 rat

Commercial Macromolecular Protein Crystal Growth (CMPCG)

CMPCG equipment provided by the University of Alabama at Birmingham and SPACEHAB, Inc. will be carried aboard the space shuttle. The CMPCG consists of 1,008 crystal growth cells, using vapor diffusion methods, trays for loading the cells, and an incubator for cell-temperature control. NASDA will use 306 of the 1,008 cells for crystal growth experiments.

Animal Enclosure Module (AEM)

The Animal Enclosure Module (AEM) provided by NASA Ames Research Center will be carried aboard the space shuttle for the experiments on rodents.



Hardware Description

The AEM is a rodent-housing facility that supports up to six 250-gram rats. The unit fits inside a standard space shuttle middeck or SPACEHAB locker with a modified locker door. The AEM remains in the stowage locker during launch and landing. On orbit, the AEM may be removed partway from the locker and the interior viewed or photographed through a Lexan cover on the top of the unit. With the addition of an Ambient Temperature Recorder, temperatures at up to four locations within the unit can be recorded automatically.

Subsystems

Air Quality: Cabin air is exchanged with the AEM through a filter system. Four fans create a slight negative pressure inside the AEM, ensuring an inward flow of air and particulate entrapment by the treated outlet filter. Cabinet air is drawn through front panel inlet slots, then along the side plenum walls to the rear of the AEM, then through the inlet filter, across the cage/animal habitat area, through the exhaust filter, and exits the front of the AEM. High-efficiency air (inlet and outlet) filters (electrostatic and phosphoric acid-treated Fiberglas pads) prevent the escape of particulate matter into the cabin atmosphere. Treated charcoal inside the filters helps contain animal odor and neutralize urine within the AEM. The filter system is rated for 21 days of odor control.

Lighting: Four internal incandescent lamps (two used as backup) provide illumination and are controlled by an automatic timer to provide a standard 12:12 light/dark cycle. The timer is programmable for other light/dark cycles and a backup battery maintains the timer if AEM power is disrupted. Only two lamps are used during the light cycle to keep cage compartment heating to a minimum. The lamps are covered with clear caps to protect them from animal debris and breakage.

Food: Rodent food bars are attached to four slide-in food bar plates inside the rodent cage. The food, a sterilized laboratory formula (either standard or principal investigator-formulated), is molded into rectangular bars accessible to the animals at all times during the mission.

Water Box: The AEM accommodates an internal water supply containing four lixit drinking valves and two flexible plastic bladders for water storage. Remaining water can be observed through the Lexan window on top of the water box.

Water Refill Box: This water refill box (WRB) is used for in-flight refill of drinking water in the AEM. Water can be pumped from the refill box to the AEM by the WRB's peristaltic pump. The bladder in the box can hold up to 3 liters. The box also can be refilled from the orbiter galley if necessary.



National Aeronautics and
Space Administration

STS-107 Shuttle Press Kit

Specifications:

Dimensions: 17(W) x 20(D) x 9.6 (H) inches

Weight: 55 lbs (including rodents, food and water)

Power: 35 W (2 lights only)



STARS Student Experiments

SPACEHAB's complement of commercial experiments includes six educational experiments designed and developed by students in six different countries under the auspices of Space Technology and Research Students (STARS), a global education program managed by SPACEHAB subsidiary Space Media. The student investigators who conceived these experiments will monitor their operations in space. The experiments will be housed in BioServe Space Technologies' Isothermal Containment Module (ICM --a small temperature-controlled facility that provides experiment support such as physical containment, lighting, and video imaging) and stowed in a middeck-size locker aboard the Research Double Module.

ASTROSPIDERS - SPIDERS IN SPACE

Glen Waverely Secondary College, Melbourne, Australia

<http://www.gwsc.vic.edu.au/stars/index.htm>

Spider silk is one of the strongest materials on Earth. Each fiber can stretch 40 percent of its length and absorb 100 times as much energy as steel without breaking. The spider's unique method of silk production is comparable to methods for producing advanced materials such as carbon fiber and Kevlar. While artificial fibers can be expensive and environmentally unfriendly, spiders can manufacture superior materials in the relatively benign environment of their internal organs. The spider species chosen for flight is the Garden Orb Weaver (*Eriophora biapicata*), because it builds a perfect orb web, renews its web every night, is nonpoisonous, has a placid nature, and is commonly found in Australia and New Zealand while similar species are found in North America.

The hypothesis for this experiment is that the spider will build a different web than the sort of web it would make on Earth. The web's makeup may also be affected. The aim of this experiment is to investigate how a spider adapts to life in microgravity, determine how spiders spin their webs in microgravity, observe how spiders eat in a weightless environment, and capture web samples for analysis on Earth.

The Victorian Department of State and Regional Development is sponsoring this experiment. The Melbourne Zoo and the RMIT University are providing assistance.

SILKWORM LIFE CYCLE DURING SPACEFLIGHT

Jingshan School, Beijing, China

The objective of this experiment is to observe and characterize the effects of spaceflight on the development of silkworm eggs, larvae, pupae, and adults. Upon their return to Earth, the silkworms and the silk they produce in space will be examined and compared to



equivalent organisms and silk grown under identical environmental conditions on the ground.

The hypothesis for this experiment is that silkworm larvae will develop differently in a low-gravity environment, possibly due to the direct effects of microgravity or to indirect effects such as altered eating habits or other behavioral changes; that microgravity will affect the placement and construction of the silkworms' cocoons as well as the process of emergence for adult moths; and that microgravity will affect the development of silkworm eggs, particularly during the first hours of cell division.

China Time Network is providing support to Jingshan School for this experiment.

CHEMICAL GARDEN

Ort-Matzkin School, Haifa, Israel

This experiment is designed to allow investigators to observe the growth of cobalt and calcium chloride salt filaments in a sodium silicate solution. In Earth gravity, thin crystal filaments grow towards the surface of the aqueous medium. Investigators surmise that this preference toward upward growth may be negated during spaceflight, allowing them to investigate the growth mechanisms of crystalline fibers.

Investigators anticipate that, in space, the crystalline fibers or filaments will grow differently in microgravity because the fiber growth mechanisms are gravitropic. One hypothesis is that air bubbles often appearing at the tips of growing filaments could act as a buoyant force, pulling filaments toward the top of the aqueous medium. A second hypothesis involves the effects of hydrostatic pressure differential. Typically, filaments grow in small stages, appearing somewhat like a continual stack of tiny spheres. The pressure differential between the top and the bottom of a sphere may cause the top of the sphere to crack and act as the nucleation site for the next sphere. In either case, elimination of the gravity field should provide insight into the growth mechanisms of salt filaments.

Technion University is providing support to this experiment.

FLIGHT OF THE MEDAKA FISH

Tokyo Institute of Technology, Tokyo, Japan

This experiment will examine the effect of microgravity on a closed aquatic environment including Medaka fish embryos during a 16-day spaceflight.

Student investigator Maki Nihori of Ochanomizu University has hypothesized that Medaka fish fry will develop faster in microgravity, possibly due to lower expenditure of energy. She also anticipates that Medaka fish fry hatched in microgravity will behave normally and have an adaptation period followed by normal swimming behavior after returning to Earth.



Sponsors and partners for this experiment include the Tokyo Institute of Technology Foundation, the Japanese Space Promotion Center, and the Japan-U.S. Science, Technology and Space Applications Program. Paragon Space Development Corp. of Tucson, Arizona, is providing its Autonomous Biological System, a self-contained life support system, for this experiment; Paragon also provided the student investigator with a two-month internship in ecosystems research.

SPICE BEES IN SPACE

Liechtenstein Gymnasium, Liechtenstein

This experiment studies the behavior of carpenter bees. Female carpenter bees construct nests by boring tunnels in flower stalks or wood. When the bees construct tunnels in wood, their chewing can be heard from several feet away. A female bee may construct several tunnels a season. Each finished tunnel branches into a series of cells, in which the female deposits pollen and nectar and then lays eggs on the food mass.

Investigators hypothesize that carpenter bees will exhibit different behaviors in microgravity than they do on Earth. Their tunneling habits will likely be altered since they may find it difficult to determine their gravity vectors in space. Tunnels drilled in space therefore may take on a different shape than those made on the ground.

The VP Bank of Liechtenstein is sponsoring this experiment.

ANTS IN SPACE

Fowler High School, Syracuse, New York

The objective of this experiment is to observe and characterize the effects of spaceflight on the tunneling behavior of harvester ants, focused on their activity level and social interactions. Upon their return to Earth, the ants and their tunnels will be examined and compared to an equivalent colony kept under similar environmental conditions on the ground. A special transparent gel will serve as the ants' tunneling medium, food and water source, and antifungal material.

The hypothesis for this experiment is that the ants will tunnel at a slower rate in microgravity than they do on Earth. Investigators anticipate that ants will tunnel and forage differently in microgravity, possibly due to the direct effects of microgravity or indirect effects such as altered eating habits or other behaviors. As the ants begin to build their tunnels as a means of foraging for food, microgravity may affect the ants' placement and construction of tunnels as well as their foraging habits. Further, microgravity may affect the structure of tunnels once they are made, particularly during the latter stages of flight. Because ants are highly social and collectively industrious creatures, some changes in colony behavior can be expected. The stresses involved in adapting to microgravity may cause deterioration in the social fabric of the colony and changes in collective behavior.



Syracuse University is providing support to this experiment.

Contacts for more information:

U.S. "Ants in Space" experiment:

Prof. Eric Spina

Syracuse University

Phone: 315-443-3604

efspina@syr.edu

Israeli "Chemical Garden" experiment:

Prof. Yigal Khomem

Technion University, Tel Aviv

Phone: 011/972-4829-4581, x. 91

khomem@techunix.technion.ac.il

Japanese "Medaka Fish" experiment:

Dr. Osamu Odawara,

odawara@echem.titech.ac.jp

Australian "Astrospiders" experiment:

Mr. Kevin Manning

Phone: 011-61-3-5995-1255

aei@hqspacehab.com

Liechtenstein "Spice Bees" experiment, Liechtenstein Gymnasium:

Mr. Manfred Schlapp

Phone: 011-42-3-236-0606

Manfred@schlapp.li

Chinese "Silk Worms in Space" experiment:

Mr. Hu Ji,

China Time Network,

Phone: 011-86-1-0639-1688, x. 309

huji@chinatimenet.com

For more information on STARS student experiments see:

<http://www.spacehab.com/stars>



Detailed Test Objectives (DTOs) and Detailed Supplementary Objectives (DSOs)

Detailed Test Objectives (DTOs)

Single String Global Positioning System (DTO 700-14)

The purpose of this experiment is to demonstrate the performance and operations of the GPS during orbiter ascent, entry and landing phases utilizing a modified military GPS receiver processor and the existing orbiter GPS antennas.

Crosswind Landing Performance (DTO 805—DTO of Opportunity)

The purpose of this experiment is to demonstrate the capability to perform a manually controlled landing in the presence of a crosswind.

Pre- and Post-flight Detailed Supplementary Objectives (DSOs)

Pharmacokinetics & Contributing Physiologic Changes During Spaceflight – Protocol B (DSO 632)

Changes in gastrointestinal function and physiology as a result of spaceflight affect drug absorption and the bioavailability of oral medications, which can compromise therapeutic effectiveness. This DSO will lead to the design and development of effective pharmacological countermeasures and therapeutic adjustments for spaceflight.

Spatial Reorientation Following Spaceflight (DSO 635)

A previous observation suggested that discordant sensory stimuli caused by an unusual motion environment disrupted spatial orientation and balance control in a returning crewmember by triggering a state change in central vestibular processing. The findings of the current investigation are expected to demonstrate the degree to which challenging motion environments may affect post-flight (re)adaptation to gravity.



Shuttle Reference Data

Shuttle Abort History

RSLS Abort History:

(STS-41 D) June 26, 1984

The countdown for the second launch attempt for Discovery's maiden flight ended at T-4 seconds when the orbiter's computers detected a sluggish valve in main engine #3. The main engine was replaced and Discovery was finally launched on August 30, 1984.

(STS-51 F) July 12, 1985

The countdown for Challenger's launch was halted at T-3 seconds when on-board computers detected a problem with a coolant valve on main engine #2. The valve was replaced and Challenger was launched on July 29, 1985.

(STS-55) March 22, 1993

The countdown for Columbia's launch was halted by on-board computers at T-3 seconds following a problem with purge pressure readings in the oxidizer preburner on main engine #2. Columbia's three main engines were replaced on the launch pad, and the flight was rescheduled behind Discovery's launch on STS-56. Columbia finally launched on April 26, 1993.

(STS-51) August 12, 1993

The countdown for Discovery's third launch attempt ended at the T-3 second mark when on-board computers detected the failure of one of four sensors in main engine #2 which monitor the flow of hydrogen fuel to the engine. All of Discovery's main engines were ordered replaced on the launch pad, delaying the Shuttle's fourth launch attempt until September 12, 1993.

(STS-68) August 18, 1994

The countdown for Endeavour's first launch attempt ended 1.9 seconds before liftoff when on-board computers detected higher than acceptable readings in one channel of a sensor monitoring the discharge temperature of the high pressure oxidizer turbopump in main engine #3. A test firing of the engine at the Stennis Space Center in Mississippi on September 2nd confirmed that a slight drift in a fuel flow meter in the engine caused a slight increase in the turbopump's temperature. The test firing also confirmed a slightly slower start for main engine #3 during the pad abort, which could have contributed to the higher temperatures. After Endeavour was brought back to the Vehicle



Assembly Building to be outfitted with three replacement engines, NASA managers set October 2nd as the date for Endeavour's second launch attempt.

Abort to Orbit History:

(STS-51 F) July 29, 1985

After an RSL abort on July 12, 1985, Challenger was launched on July 29, 1985. Five minutes and 45 seconds after launch, a sensor problem resulted in the shutdown of center engine #1, resulting in a safe "abort to orbit" and successful completion of the mission.



Shuttle Reference Data

Shuttle Abort Modes

RSLs ABORTS

These occur when the onboard shuttle computers detect a problem and command a halt in the launch sequence after taking over from the Ground Launch Sequencer and before Solid Rocket Booster ignition.

ASCENT ABORTS

Selection of an ascent abort mode may become necessary if there is a failure that affects vehicle performance, such as the failure of a space shuttle main engine or an orbital maneuvering system. Other failures requiring early termination of a flight, such as a cabin leak, might also require the selection of an abort mode. There are two basic types of ascent abort modes for space shuttle missions: intact aborts

and contingency aborts. Intact aborts are designed to provide a safe return of the orbiter to a planned landing site. Contingency aborts are designed to permit flight crew survival following more severe failures when an intact abort is not possible. A contingency abort would generally result in a ditch operation.

INTACT ABORTS

There are four types of intact aborts: abort to orbit (ATO), abort once around (AOA), transoceanic abort landing (TAL) and return to launch site (RTLs).

Return to Launch Site

The RTLs abort mode is designed to allow the return of the orbiter, crew, and payload to the launch site, Kennedy Space Center, approximately 25 minutes after lift-off. The RTLs profile is designed to accommodate the loss of thrust from one space shuttle main engine between lift-off and approximately four minutes 20 seconds, at which time not enough main propulsion system propellant remains to return to the launch site. An RTLs can be considered to consist of three stages--a powered stage, during which the space shuttle main engines are still thrusting; an ET separation phase; and the glide phase, during which the orbiter glides to a landing at the Kennedy Space Center. The powered RTLs phase begins with the crew selection of the RTLs abort, which is done after solid rocket booster separation. The crew selects the abort mode by positioning the abort rotary switch to RTLs and depressing the abort push button. The time at which the RTLs is selected depends on the reason for the abort. For example, a three-engine RTLs is selected at the last moment, approximately three minutes 34 seconds into the mission; whereas an RTLs chosen due to



an engine out at lift-off is selected at the earliest time, approximately two minutes 20 seconds into the mission (after solid rocket booster separation).

After RTLS is selected, the vehicle continues downrange to dissipate excess main propulsion system propellant. The goal is to leave only enough main propulsion system propellant to be able to turn the vehicle around, fly back towards the Kennedy Space Center and achieve the proper main engine cutoff conditions so the vehicle can glide to the Kennedy Space Center after external tank separation. During the downrange phase, a pitch-around maneuver is initiated (the time depends in part on the time of a space shuttle main engine failure) to orient the orbiter/external tank configuration to a heads up attitude, pointing toward the launch site. At this time, the vehicle is still moving away from the launch site, but the space shuttle main engines are now thrusting to null the downrange velocity. In addition, excess orbital maneuvering system and reaction control system propellants are dumped by continuous orbital maneuvering system and reaction control system engine thrustings to improve the orbiter weight and center of gravity for the glide phase and landing.

The vehicle will reach the desired main engine cutoff point with less than 2 percent excess propellant remaining in the external tank. At main engine cutoff minus 20 seconds, a pitchdown maneuver (called powered pitch-down) takes the mated vehicle to the required external tank separation attitude and pitch rate. After main engine cutoff has been commanded, the external tank separation sequence begins, including a reaction control system translation that ensures that the orbiter does not recontact the external tank and that the orbiter has achieved the necessary pitch attitude to begin the glide phase of the RTLS.

After the reaction control system translation maneuver has been completed, the glide phase of the RTLS begins. From then on, the RTLS is handled similarly to a normal entry.

Transoceanic Abort Landing

The TAL abort mode was developed to improve the options available when a space shuttle main engine fails after the last RTLS opportunity but before the first time that an AOA can be accomplished with only two space shuttle main engines or when a major orbiter system failure, for example, a large cabin pressure leak or cooling system failure, occurs after the last RTLS opportunity, making it imperative to land as quickly as possible.

In a TAL abort, the vehicle continues on a ballistic trajectory across the Atlantic Ocean to land at a predetermined runway. Landing occurs approximately 45 minutes after launch. The landing site is selected near the nominal ascent ground track of the orbiter in order to make the most efficient use of space shuttle main engine propellant. The landing site also must have the necessary runway length, weather conditions and U.S. State Department approval. Currently, the three landing sites that have been identified for a due east launch are Moron, Spain; Zaragoza, Spain; and Ben Guerur, Morocco (on the west coast of Africa).



To select the TAL abort mode, the crew must place the abort rotary switch in the TAL/AOA position and depress the abort push button before main engine cutoff. (Depressing it after main engine cutoff selects the AOA abort mode.) The TAL abort mode begins sending commands to steer the vehicle toward the plane of the landing site. It also rolls the vehicle heads up before main engine cutoff and sends commands to begin an orbital maneuvering system propellant dump (by burning the propellants through the orbital maneuvering system engines and the reaction control system engines). This dump is necessary to increase vehicle performance (by decreasing weight), to place the center of gravity in the proper place for vehicle control, and to decrease the vehicle's landing weight.

TAL is handled like a nominal entry.

Abort to Orbit

An ATO is an abort mode used to boost the orbiter to a safe orbital altitude when performance has been lost and it is impossible to reach the planned orbital altitude. If a space shuttle main engine fails in a region that results in a main engine cutoff under speed, the Mission Control Center will determine that an abort mode is necessary and will inform the crew. The orbital maneuvering system engines would be used to place the orbiter in a circular orbit.

Abort Once Around

The AOA abort mode is used in cases in which vehicle performance has been lost to such an extent that either it is impossible to achieve a viable orbit or not enough orbital maneuvering system propellant is available to accomplish the orbital maneuvering system thrusting maneuver to place the orbiter on orbit and the deorbit thrusting maneuver. In addition, an AOA is used in cases in which a major systems problem (cabin leak, loss of cooling) makes it necessary to land quickly. In the AOA abort mode, one orbital maneuvering system thrusting sequence is made to adjust the post-main engine cutoff orbit so a second orbital maneuvering system thrusting sequence will result in the vehicle deorbiting and landing at the AOA landing site (White Sands, N.M.; Edwards Air Force Base; or the Kennedy Space Center). Thus, an AOA results in the orbiter circling the Earth once and landing approximately 90 minutes after lift-off.

After the deorbit thrusting sequence has been executed, the flight crew flies to a landing at the planned site much as it would for a nominal entry.

CONTINGENCY ABORTS

Contingency aborts are caused by loss of more than one main engine or failures in other systems. Loss of one main engine while another is stuck at a low thrust setting may also necessitate a contingency abort. Such an abort would maintain orbiter integrity for in-flight crew escape if a landing cannot be achieved at a suitable landing field.



Contingency aborts due to system failures other than those involving the main engines would normally result in an intact recovery of vehicle and crew. Loss of more than one main engine may, depending on engine failure times, result in a safe runway landing. However, in most three-engine-out cases during ascent, the orbiter would have to be ditched. The inflight crew escape system would be used before ditching the orbiter.

ABORT DECISIONS

There is a definite order of preference for the various abort modes. The type of failure and the time of the failure determine which type of abort is selected. In cases where performance loss is the only factor, the preferred modes would be ATO, AOA, TAL and RTLS, in that order. The mode chosen is the highest one that can be completed with the remaining vehicle performance.

In the case of some support system failures, such as cabin leaks or vehicle cooling problems, the preferred mode might be the one that will end the mission most quickly. In these cases, TAL or RTLS might be preferable to AOA or ATO. A contingency abort is never chosen if another abort option exists.

The Mission Control Center-Houston is prime for calling these aborts because it has a more precise knowledge of the orbiter's position than the crew can obtain from onboard systems. Before main engine cutoff, Mission Control makes periodic calls to the crew to tell them which abort mode is (or is not) available. If ground communications are lost, the flight crew has onboard methods, such as cue cards, dedicated displays and display information, to determine the current abort region.

Which abort mode is selected depends on the cause and timing of the failure causing the abort and which mode is safest or improves mission success. If the problem is a space shuttle main engine failure, the flight crew and Mission Control Center select the best option available at the time a space shuttle main engine fails.

If the problem is a system failure that jeopardizes the vehicle, the fastest abort mode that results in the earliest vehicle landing is chosen. RTLS and TAL are the quickest options (35 minutes), whereas an AOA requires approximately 90 minutes. Which of these is selected depends on the time of the failure with three good space shuttle main engines.

The flight crew selects the abort mode by positioning an abort mode switch and depressing an abort push button.



Shuttle Reference Data

Space Shuttle Rendezvous Maneuvers

COMMON SHUTTLE RENDEZVOUS MANEUVERS

OMS-1 (Orbit insertion) - Rarely used ascent abort burn

OMS-2 (Orbit insertion) - Typically used to circularize the initial orbit following ascent, completing orbital insertion. For ground-up rendezvous flights, also considered a rendezvous phasing burn

NC (Rendezvous phasing) - Performed to hit a range relative to the target at a future time

NH (Rendezvous height adjust) - Performed to hit a delta-height relative to the target at a future time

NPC (Rendezvous plane change) - Performed to remove planar errors relative to the target at a future time

NCC (Rendezvous corrective combination) - First on-board targeted burn in the rendezvous sequence. Using star tracker data, it is performed to remove phasing and height errors relative to the target at T_i

Ti (Rendezvous terminal intercept) - Second on-board targeted burn in the rendezvous sequence. Using primarily rendezvous radar data, it places the Orbiter on a trajectory to intercept the target in one orbit

MC-1, MC-2, MC-3, MC-4 (Rendezvous midcourse burns) - These on-board targeted burns use star tracker and rendezvous radar data to correct the post-Ti trajectory in preparation for the final, manual proximity operations phase



Shuttle Reference Data

Space Shuttle Main Engines

Developed in the 1970s by NASA's Marshall Space Flight Center in Huntsville, Ala., the Space Shuttle Main Engine is the most advanced liquid-fueled rocket engine ever built. Its main features include variable thrust, high performance, reusability, high redundancy, and a fully integrated engine controller.

The shuttle's three main engines are mounted on the Orbiter aft fuselage in a triangular pattern. Spaced so that they are movable during launch, the engines are used – in conjunction with the Solid Rocket Boosters – to steer the shuttle vehicle.

Each of these powerful main engines is 14 feet (4.2 meters) long, weighs approximately 7,000 pounds (3,150 kilograms) and is 7.5 feet (2.25 meters) in diameter at the end of its nozzle.

The engines operate for about eight-and-one-half minutes during liftoff and ascent -- burning more than 500,000 gallons (1.9 million liters) of super-cold liquid hydrogen and liquid oxygen propellants stored in the huge external tank attached to the underside of the shuttle. The engines shut down just before the shuttle, traveling at about 17,000 mph (28,000 kilometers per hour), reaches orbit.

The Main Engine operates at greater temperature extremes than any mechanical system in common use today. The fuel, liquefied hydrogen at -423 degrees Fahrenheit (-253 degrees Celsius) is the second coldest liquid on Earth. When it and the liquid oxygen are combusted, the temperature in the main combustion chamber is 6,000 degrees Fahrenheit (3,316 degrees Celsius), hotter than the boiling point of iron.

The main engines use a staged combustion cycle so that all propellants entering the engines are used to produce thrust or power -- more efficiently than any previous rocket engine. In a staged combustion cycle, propellants are first burned partially at high pressure and relatively low temperature -- then burned completely at high temperature and pressure in the main combustion chamber. The rapid mixing of the propellants under these conditions is so complete that 99 percent of the fuel is burned.

At normal operating level, the engines generate 490,847 pounds of thrust (measured in a vacuum). Full power is 512,900 pounds of thrust; minimum power is at 316,100 pounds of thrust.

The engine can be throttled by varying the output of the pre-burners, thus varying the speed of the high-pressure turbopumps and, therefore, the flow of the propellant.



At approximately 26 seconds into launch the main engines are throttled down to 316,000 pounds of thrust to keep the dynamic pressure on the vehicle below a specified level -- about 580 pounds per square foot or max q. Then, the engines are throttled back up to normal operating level at approximately 60 seconds. This reduces stress on the vehicle.

The main engines are throttled down again at approximately seven minutes 40 seconds into the mission to maintain 3 g's – three times the Earth's gravitational pull – again reducing stress on the crew and the vehicle. This acceleration level is about one-third the acceleration experienced on previous crewed space flights.

Approximately 10 seconds before Main Engine Cutoff or MECO, the cutoff sequence begins; about three seconds later the main engines are commanded to begin throttling at 10-percent thrust per second to 65-percent thrust. This is held for approximately 6.7seconds, and the engines are shut down.

The engine performance has the highest thrust for its weight of any engine yet developed. In fact, one Space Shuttle Main Engine generates sufficient thrust to maintain the flight of two-and-one-half 747 airplanes.

The Space Shuttle Main Engine is also the first rocket engine to use a built-in electronic digital controller, or computer. The controller will accept commands from the Orbiter for engine start, change in throttle, shutdown, and monitor engine operation. In the event of a failure, the controller automatically corrects the problem or safely shuts down the engine.

NASA continues to increase the reliability and safety of shuttle flights through a series of enhancements to the Space Shuttle Main Engines. The engines were modified in 1988, 1995, 1998 and 2001. Modifications include new high-pressure fuel and oxidizer turbopumps that reduce maintenance and operating costs of the engine, a two-duct powerhead that reduces pressure and turbulence in the engine, a single-coil heat exchanger that lowers the number of post flight inspections required. Another modification incorporates a large-throat main combustion chamber that improves the engine's reliability by reducing pressure and temperature in the chamber.

NASA projects an upcoming enhancement – the Advanced Health Management System – will further improve safety, reliability and performance. The Advanced Health Management System is a high tech system that couples optical and vibration sensors with advanced processing and computing technology. It will monitor the main engines and “see” any problems. After the orbiter lands, the engines are removed and returned to a processing facility at Kennedy Space Center, Fla., where they are rechecked and readied for the next flight. Some components are returned to the main engine's prime contractor, Rocketdyne Propulsion & Power unit of the Boeing Company, Canoga Park, Calif., for regular maintenance. The main engines are designed to operate for 7.5 accumulated hours.



Shuttle Reference Data

Space Shuttle Solid Rocket Boosters

The two SRBs provide the main thrust to lift the space shuttle off the pad and up to an altitude of about 150,000 feet, or 24 nautical miles (28 statute miles). In addition, the two SRBs carry the entire weight of the external tank and orbiter and transmit the weight load through their structure to the mobile launcher platform.

Each booster has a thrust (sea level) of approximately 3,300,000 pounds at launch. They are ignited after the three space shuttle main engines' thrust level is verified. The two SRBs provide 71.4 percent of the thrust at lift-off and during first-stage ascent. Seventy-five seconds after SRB separation, SRB apogee occurs at an altitude of approximately 220,000 feet, or 35 nautical miles (40 statute miles). SRB impact occurs in the ocean approximately 122 nautical miles (140 statute miles) downrange.

The SRBs are the largest solid-propellant motors ever flown and the first designed for reuse. Each is 149.16 feet long and 12.17 feet in diameter.

Each SRB weighs approximately 1,300,000 pounds at launch. The propellant for each solid rocket motor weighs approximately 1,100,000 pounds. The inert weight of each SRB is approximately 192,000 pounds.

Primary elements of each booster are the motor (including case, propellant, igniter and nozzle), structure, separation systems, operational flight instrumentation, recovery avionics, pyrotechnics, deceleration system, thrust vector control system and range safety destruct system.

Each booster is attached to the external tank at the SRB's aft frame by two lateral sway braces and a diagonal attachment. The forward end of each SRB is attached to the external tank at the forward end of the SRB's forward skirt. On the launch pad, each booster also is attached to the mobile launcher platform at the aft skirt by four bolts and nuts that are severed by small explosives at lift-off.

During the downtime following the Challenger accident, detailed structural analyses were performed on critical structural elements of the SRB. Analyses were primarily focused in areas where anomalies had been noted during postflight inspection of recovered hardware.

One of the areas was the attach ring where the SRBs are connected to the external tank. Areas of distress were noted in some of the fasteners where the ring attaches to the SRB motor case. This situation was attributed to the high loads encountered during water impact. To correct the situation and ensure higher strength margins during ascent, the attach ring was redesigned to encircle the motor case completely (360 degrees). Previously, the attach ring formed a C and encircled the motor case 270 degrees.



Additionally, special structural tests were performed on the aft skirt. During this test program, an anomaly occurred in a critical weld between the hold-down post and skin of the skirt. A redesign was implemented to add reinforcement brackets and fittings in the aft ring of the skirt.

These two modifications added approximately 450 pounds to the weight of each SRB.

The propellant mixture in each SRB motor consists of an ammonium perchlorate (oxidizer, 69.6 percent by weight), aluminum (fuel, 16 percent), iron oxide (a catalyst, 0.4 percent), a polymer (a binder that holds the mixture together, 12.04 percent), and an epoxy curing agent (1.96 percent). The propellant is an 11-point star-shaped perforation in the forward motor segment and a double-truncated-cone perforation in each of the aft segments and aft closure. This configuration provides high thrust at ignition and then reduces the thrust by approximately a third 50 seconds after lift-off to prevent overstressing the vehicle during maximum dynamic pressure.

The SRBs are used as matched pairs and each is made up of four solid rocket motor segments. The pairs are matched by loading each of the four motor segments in pairs from the same batches of propellant ingredients to minimize any thrust imbalance. The segmented-casing design assures maximum flexibility in fabrication and ease of transportation and handling. Each segment is shipped to the launch site on a heavy-duty rail car with a specially built cover.

The nozzle expansion ratio of each booster beginning with the STS-8 mission is 7-to-79. The nozzle is gimballed for thrust vector (direction) control. Each SRB has its own redundant auxiliary power units and hydraulic pumps. The all-axis gimbaling capability is 8 degrees. Each nozzle has a carbon cloth liner that erodes and chars during firing. The nozzle is a convergent-divergent, movable design in which an aft pivot-point flexible bearing is the gimbal mechanism.

The cone-shaped aft skirt reacts the aft loads between the SRB and the mobile launcher platform. The four aft separation motors are mounted on the skirt. The aft section contains avionics, a thrust vector control system that consists of two auxiliary power units and hydraulic pumps, hydraulic systems and a nozzle extension jettison system.

The forward section of each booster contains avionics, a sequencer, forward separation motors, a nose cone separation system, drogue and main parachutes, a recovery beacon, a recovery light, a parachute camera on selected flights and a range safety system.

Each SRB has two integrated electronic assemblies, one forward and one aft. After burnout, the forward assembly initiates the release of the nose cap and frustum and turns on the recovery aids. The aft assembly, mounted in the external tank/SRB attach ring, connects with the forward assembly and the orbiter avionics systems for SRB ignition commands and nozzle thrust vector control. Each integrated electronic assembly has a



multiplexer/ demultiplexer, which sends or receives more than one message, signal or unit of information on a single communication channel.

Eight booster separation motors (four in the nose frustum and four in the aft skirt) of each SRB thrust for 1.02 seconds at SRB separation from the external tank. Each solid rocket separation motor is 31.1 inches long and 12.8 inches in diameter.

Location aids are provided for each SRB, frustum/drogue chutes and main parachutes. These include a transmitter, antenna, strobe/converter, battery and salt water switchelectronics. The location aids are designed for a minimum operating life of 72 hours and when refurbished are considered usable up to 20 times. The flashing light is an exception. It has an operating life of 280 hours. The battery is used only once.

The SRB nose caps and nozzle extensions are not recovered.

The recovery crew retrieves the SRBs, frustum/drogue chutes, and main parachutes. The nozzles are plugged, the solid rocket motors are dewatered, and the SRBs are towed back to the launch site. Each booster is removed from the water, and its components are disassembled and washed with fresh and deionized water to limit salt water corrosion. The motor segments, igniter and nozzle are shipped back to Thiokol for refurbishment.

Each SRB incorporates a range safety system that includes a battery power source, receiver/ decoder, antennas and ordnance.

HOLD-DOWN POSTS

Each solid rocket booster has four hold-down posts that fit into corresponding support posts on the mobile launcher platform. Hold-down bolts hold the SRB and launcher platform posts together. Each bolt has a nut at each end, but only the top nut is frangible. The top nut contains two NASA standard detonators, which are ignited at solid rocket motor ignition commands.

When the two NSDs are ignited at each hold-down, the hold-down bolt travels downward because of the release of tension in the bolt (pretensioned before launch), NSD gas pressure and gravity. The bolt is stopped by the stud deceleration stand, which contains sand. The SRB bolt is 28 inches long and is 3.5 inches in diameter. The frangible nut is captured in a blast container.

The solid rocket motor ignition commands are issued by the orbiter's computers through the master events controllers to the hold-down pyrotechnic initiator controllers on the mobile launcher platform. They provide the ignition to the hold-down NSDs. The launch processing system monitors the SRB hold-down PICs for low voltage during the last 16 seconds before launch. PIC low voltage will initiate a launch hold.



SRB IGNITION

SRB ignition can occur only when a manual lock pin from each SRB safe and arm device has been removed. The ground crew removes the pin during prelaunch activities. At T minus five minutes, the SRB safe and arm device is rotated to the arm position. The solid rocket motor ignition commands are issued when the three SSMEs are at or above 90-percent rated thrust, no SSME fail and/or SRB ignition PIC low voltage is indicated and there are no holds from the LPS.

The solid rocket motor ignition commands are sent by the orbiter computers through the MECs to the safe and arm device NSDs in each SRB. A PIC single-channel capacitor discharge device controls the firing of each pyrotechnic device. Three signals must be present simultaneously for the PIC to generate the pyro firing output. These signals--arm, fire 1 and fire 2--originate in the orbiter general-purpose computers and are transmitted to the MECs. The MECs reformat them to 28-volt dc signals for the PICs. The arm signal charges the PIC capacitor to 40 volts dc (minimum of 20 volts dc).

The fire 2 commands cause the redundant NSDs to fire through a thin barrier seal down a flame tunnel. This ignites a pyro booster charge, which is retained in the safe and arm device behind a perforated plate. The booster charge ignites the propellant in the igniter initiator; and combustion products of this propellant ignite the solid rocket motor initiator, which fires down the length of the solid rocket motor igniting the solid rocket motor propellant.

The GPC launch sequence also controls certain critical main propulsion system valves and monitors the engine-ready indications from the SSMEs. The MPS start commands are issued by the onboard computers at T minus 6.6 seconds (staggered start--engine three, engine two, engine one--all approximately within 0.25 of a second), and the sequence monitors the thrust buildup of each engine. All three SSMEs must reach the required 90-percent thrust within three seconds; otherwise, an orderly shutdown is commanded and safing functions are initiated.

Normal thrust buildup to the required 90-percent thrust level will result in the SSMEs being commanded to the lift-off position at T minus three seconds as well as the fire 1 command being issued to arm the SRBs. At T minus three seconds, the vehicle base bending load modes are allowed to initialize (movement of approximately 25.5 inches measured at the tip of the external tank, with movement towards the external tank).

At T minus zero, the two SRBs are ignited, under command of the four onboard computers; separation of the four explosive bolts on each SRB is initiated (each bolt is 28 inches long and 3.5 inches in diameter); the two T-0 umbilicals (one on each side of the spacecraft) are retracted; the onboard master timing unit, event timer and mission event timers are started; the three SSMEs are at 100 percent; and the ground launch sequence is terminated.



The solid rocket motor thrust profile is tailored to reduce thrust during the maximum dynamic pressure region.

ELECTRICAL POWER DISTRIBUTION

Electrical power distribution in each SRB consists of orbiter-supplied main dc bus power to each SRB via SRB buses A, B and C. Orbiter main dc buses A, B and C supply main dc bus power to corresponding SRB buses A, B and C. In addition, orbiter main dc bus C supplies backup power to SRB buses A and B, and orbiter bus B supplies backup power to SRB bus C. This electrical power distribution arrangement allows all SRB buses to remain powered in the event one orbiter main bus fails.

The nominal dc voltage is 28 volts dc, with an upper limit of 32 volts dc and a lower limit of 24 volts dc.

HYDRAULIC POWER UNITS

There are two self-contained, independent HPUs on each SRB. Each HPU consists of an auxiliary power unit, fuel supply module, hydraulic pump, hydraulic reservoir and hydraulic fluid manifold assembly. The APUs are fueled by hydrazine and generate mechanical shaft power to a hydraulic pump that produces hydraulic pressure for the SRB hydraulic system. The two separate HPUs and two hydraulic systems are located on the aft end of each SRB between the SRB nozzle and aft skirt. The HPU components are mounted on the aft skirt between the rock and tilt actuators. The two systems operate from T minus 28 seconds until SRB separation from the orbiter and external tank. The two independent hydraulic systems are connected to the rock and tilt servoactuators.

The APU controller electronics are located in the SRB aft integrated electronic assemblies on the aft external tank attach rings.

The APUs and their fuel systems are isolated from each other. Each fuel supply module (tank) contains 22 pounds of hydrazine. The fuel tank is pressurized with gaseous nitrogen at 400 psi, which provides the force to expel (positive expulsion) the fuel from the tank to the fuel distribution line, maintaining a positive fuel supply to the APU throughout its operation.

The fuel isolation valve is opened at APU startup to allow fuel to flow to the APU fuel pump and control valves and then to the gas generator. The gas generator's catalytic action decomposes the fuel and creates a hot gas. It feeds the hot gas exhaust product to the APU two-stage gas turbine. Fuel flows primarily through the startup bypass line until the APU speed is such that the fuel pump outlet pressure is greater than the bypass line's. Then all the fuel is supplied to the fuel pump.

The APU turbine assembly provides mechanical power to the APU gearbox. The gearbox drives the APU fuel pump, hydraulic pump and lube oil pump. The APU lube oil pump



lubricates the gearbox. The turbine exhaust of each APU flows over the exterior of the gas generator, cooling it, and is then directed overboard through an exhaust duct.

When the APU speed reaches 100 percent, the APU primary control valve closes, and the APU speed is controlled by the APU controller electronics. If the primary control valve logic fails to the open state, the secondary control valve assumes control of the APU at 112-percent speed.

Each HPU on an SRB is connected to both servoactuators on that SRB. One HPU serves as the primary hydraulic source for the servoactuator, and the other HPU serves as the secondary hydraulics for the servoactuator. Each servoactuator has a switching valve that allows the secondary hydraulics to power the actuator if the primary hydraulic pressure drops below 2,050 psi. A switch contact on the switching valve will close when the valve is in the secondary position. When the valve is closed, a signal is sent to the APU controller that inhibits the 100-percent APU speed control logic and enables the 112-percent APU speed control logic. The 100-percent APU speed enables one APU/HPU to supply sufficient operating hydraulic pressure to both servoactuators of that SRB.

The APU 100-percent speed corresponds to 72,000 rpm, 110-percent to 79,200 rpm, and 112-percent to 80,640 rpm.

The hydraulic pump speed is 3,600 rpm and supplies hydraulic pressure of 3,050, plus or minus 50, psi. A high-pressure relief valve provides overpressure protection to the hydraulic system and relieves at 3,750 psi.

The APUs/HPUs and hydraulic systems are reusable for 20 missions.

THRUST VECTOR CONTROL

Each SRB has two hydraulic gimbal servoactuators: one for rock and one for tilt. The servoactuators provide the force and control to gimbal the nozzle for thrust vector control.

The space shuttle ascent thrust vector control portion of the flight control system directs the thrust of the three shuttle main engines and the two SRB nozzles to control shuttle attitude and trajectory during lift-off and ascent. Commands from the guidance system are transmitted to the ATVC drivers, which transmit signals proportional to the commands to each servoactuator of the main engines and SRBs. Four independent flight control system channels and four ATVC channels control six main engine and four SRB ATVC drivers, with each driver controlling one hydraulic port on each main and SRB servoactuator.

Each SRB servoactuator consists of four independent, two-stage servovalves that receive signals from the drivers. Each servovalve controls one power spool in each actuator, which positions an actuator ram and the nozzle to control the direction of thrust.



The four servovalves in each actuator provide a force-summed majority voting arrangement to position the power spool. With four identical commands to the four servovalves, the actuator force-sum action prevents a single erroneous command from affecting power ram motion. If the erroneous command persists for more than a predetermined time, differential pressure sensing activates a selector valve to isolate and remove the defective servovalve hydraulic pressure, permitting the remaining channels and servovalves to control the actuator ram spool.

Failure monitors are provided for each channel to indicate which channel has been bypassed. An isolation valve on each channel provides the capability of resetting a failed or bypassed channel.

Each actuator ram is equipped with transducers for position feedback to the thrust vector control system. Within each servoactuator ram is a splashdown load relief assembly to cushion the nozzle at water splashdown and prevent damage to the nozzle flexible bearing.

SRB RATE GYRO ASSEMBLIES

Each SRB contains two RGAs, with each RGA containing one pitch and one yaw gyro. These provide an output proportional to angular rates about the pitch and yaw axes to the orbiter computers and guidance, navigation and control system during first-stage ascent flight in conjunction with the orbiter roll rate gyros until SRB separation. At SRB separation, a switchover is made from the SRB RGAs to the orbiter RGAs.

The SRB RGA rates pass through the orbiter flight aft multiplexers/ demultiplexers to the orbiter GPCs. The RGA rates are then mid-value- selected in redundancy management to provide SRB pitch and yaw rates to the user software. The RGAs are designed for 20 missions.

SRB SEPARATION

SRB separation is initiated when the three solid rocket motor chamber pressure transducers are processed in the redundancy management middle value select and the head-end chamber pressure of both SRBs is less than or equal to 50 psi. A backup cue is the time elapsed from booster ignition.

The separation sequence is initiated, commanding the thrust vector control actuators to the null position and putting the main propulsion system into a second-stage configuration (0.8 second from sequence initialization), which ensures the thrust of each SRB is less than 100,000 pounds. Orbiter yaw attitude is held for four seconds, and SRB thrust drops to less than 60,000 pounds.

The SRBs separate from the external tank within 30 milliseconds of the ordnance firing command.



The forward attachment point consists of a ball (SRB) and socket (ET) held together by one bolt. The bolt contains one NSD pressure cartridge at each end. The forward attachment point also carries the range safety system cross-strap wiring connecting each SRB RSS and the ET RSS with each other.

The aft attachment points consist of three separate struts: upper, diagonal and lower. Each strut contains one bolt with an NSD pressure cartridge at each end. The upper strut also carries the umbilical interface between its SRB and the external tank and on to the orbiter.

There are four booster separation motors on each end of each SRB. The BSMs separate the SRBs from the external tank. The solid rocket motors in each cluster of four are ignited by firing redundant NSD pressure cartridges into redundant confined detonating fuse manifolds.

The separation commands issued from the orbiter by the SRB separation sequence initiate the redundant NSD pressure cartridge in each bolt and ignite the BSMs to effect a clean separation.



Shuttle Reference Data

Space Shuttle Super Light Weight Tank (SLWT)

The super lightweight external tank (SLWT) made its first shuttle flight June 2, 1998, on mission STS-91. The SLWT is 7,500 pounds lighter than the standard external tank. The lighter weight tank will allow the shuttle to deliver International Space Station elements (such as the service module) into the proper orbit.

The SLWT is the same size as the previous design. But the liquid hydrogen tank and the liquid oxygen tank are made of aluminum lithium, a lighter, stronger material than the metal alloy used for the shuttle's current tank. The tank's structural design has also been improved, making it 30% stronger and 5% less dense.

The SLWT, like the standard tank, is manufactured at Michoud Assembly, near New Orleans, Louisiana, by Lockheed Martin.

The 154-foot-long external tank is the largest single component of the space shuttle. It stands taller than a 15-story building and has a diameter of about 27 feet. The external tank holds over 530,000 gallons of liquid hydrogen and liquid oxygen in two separate tanks. The hydrogen (fuel) and liquid oxygen (oxidizer) are used as propellants for the shuttle's three main engines.



Acronyms and Abbreviations

A/D	Analog to Digital
ACCESS	Advanced Carrier Equipment Support System
ADC	Analog-to-Digital Conversion
ADVCR	Airborne Digital Video Camera Recorder
AIA	Avionics Interface Adapter
AIREX	TBD
AMP	Avionics Mounting Plate
AMS	Alpha Magnetic Spectrometer
AMUX	AIA Analog Multiplexer
AP	Avionics Package
APVM	TBD
ASPC	Attached Shuttle Payload Center
ATLAS	Analysis of Thrust Structure Loads and Stresses
B-SROC	Belgian Space Remote Operation Center
B-USOC	Belgian-University Science Operation Center
BDRF	Bidirectional Reflectivity
BIA	Bus Interface Adapter
C&DH	Command and Data Handling Subsystem
CANDOS	Communications and Navigation Demonstration on Shuttle
CCD	Charge Coupled Device
CCTV	Closed-Circuit Television
CDHS	Command and Data Handling System
CGSE	Customer Ground Support Equipment
CPM	Central Processing Module
CPU	Central Processing Unit
CVX	Critical Viscosity in Xenon
D/A	Digital to Analog
DACS	Digital Acquisition and Control System
dc	direct current
DFRC	Dryden Flight Research Facility
DIARAD	Differential Absolute Radiometer
DPU	Digital Processing Unit
DSP	Digital Signal Processor
DTMF	Dual Tone Multifrequency
DTP	Data Take Period
EDO	Extended Duration Orbiter
EEPROM	Electrically Erasable Read-Only Memory



EMI	Electromagnetic Interference
EMP	Experiment Mounting Plate
EP	Experiment Package
EPROM	Erasable Programmable Read-Only Memory
ESA	European Space Agency
ESOC	European Space Operations Cent
EURECA	European Retrievable Carrier
EVA	Extravehicular Activity
FCP	Fuel Cell Purge
FES	Flash Evaporator System
FOV	Field of View
FREESTAR	Fast Reaction Enabling Science Technology and Research
GLAS	Geoscience Laser Altimeter System
GMT	Greenwich Mean Time
GN	Ground Network
GPS	Global Positioning System
GRC	Glenn Research Center
GSE	Ground Support Equipment
GSFC	Goddard Space Flight Center
HH	Hitchhiker
HH-Jr.	Hitchhiker Junior
HMDA	Hitchhiker Motorized Door Assembly
HOP	High Output Paraffin
HRIU	Hitchhiker Remote Interface Unit
HVIU	Hitchhiker Video Interface Unit
HVODS	TBD
I/O	Input/Output
IFM	In-Flight Maintenance
IP	Internet Protocol
IR	Infrared
IRIG-B	Interrange Instrumentation Group Type B
ISS	International Space Station
JSC	Johnson Space Center
KUSP	Ku-Band Signal Processor
LED	Light Emitting Diode
LEP	Lower End Plate
LISA	Lid Interlock Switch Assembly
LMT	Landmark Track Maneuver



LORE	Limb Ozone Retrieval Experiment
LOS	Loss of Signal
LPT	Low Power Transceiver
LV	Low Voltage
MA	Multiaccess
MCC-H	Mission Control Center - Houston
MCU	Master Control Unit
MDM	Multiplexer/Demultiplexer
MDRU	Medium Rate Data Processing Unit
MEIDEX	Mediterranean Israeli Dust Experiment
MET	Mission Elapsed Time
MILA	Merritt Island
MLI	Multilayer Insulation
MMM	Mass Memory Module
MMU	Mass Memory Unit
MODIS	Moderate Resolution Imaging Spectro-radiometer
MRM	Medium Rate Multiplexer
MPESS	Multipurpose Experiment Support Structure
MSOCC	Multisatellite Operations Control Center
MSTRS	Miniature Satellite Threat Reporting System
Mux	Multiplexer
NASA	National Aeronautics and Space Administration
NCEP	National Centers for Environmental Protection
NET	Not Earlier Than
NIST	National Institute of Science and Technology
NLT	Not Later Than
NOAA	National Oceanic and Atmospheric Administration
NOAH	TBD
OCA	Orbiter Communications Adapter
ODERACS	Orbital Debris Radar Calibration System
OMS	Orbital Maneuvering System
OSC	Orbital Sciences Corporation
PCB	Printed Circuit Board
PCM	Pulse Control Modulation
PDI	Payload Data Interleaver
PET	Payload Event Time
PGSC	Payload General Support Computer
PI	Payload Interrogator
PL CAB	Payload Cabin
PL PRI	Payload Primary



PLB	Payload Bay
PLBD	Payload Bay Door
PMT	TBD
POCC	Payload Operations Control Center
PRCS	Primary Reaction Control System
PSP	Payload Signal Processor
PSRD	Prototype Synchrotron Radiation Detector
PTB	Payload Timing Butter
RDM	Research Double Module
RF	Radio Frequency
RFI	Radio Frequency Interference
ROI	Regions of Interest
RUPS	Recorder Utility Processing System
SAA	South Atlantic Anomaly
SARR	TBD
SBP	Single Bay Pallet
SEM	Space Experiment Module
SIM	Spacecraft Interface Module
SMA	TBD
SOLCON	Solar Constant Experiment
SOLSE	Shuttle Ozone Limb Sounding Experiment
SPIF	Shuttle/POCC Interface Facility
SOVA	TBD
SROC	Space Remote Operation Center
SSP	Standard Switch Panel SOLCON Science Program
SSPP	Small Shuttle Payload Program
SSPPO	Small Shuttle Payload Program Office
STD	Standard
T-Mux	Thermal Multiplexer
TAC	Telemetry and Command Processor
T _c	Critical Temperature
TCA	Time of Closest Approach
TDM	Time-Division Multiplexer
TDRS	Track and Data Relay Satellite
TDRSS	Tracking and Data Relay Satellite System
TEC	Thermoelectric Cooler
TIM	Time Interface Module
TLE	Transient Luminous Event
TMON	Target Monitor
TOMS	Total Ozone Mapping Spectrometer



TR	Terminator Rise
TS	Terminator Set
TSD	Technical Services Division
UARS	Upper Atmosphere Research Satellite
UEP	Upper End Plate Upper Atmosphere Research Satellite
UIM	User Interface Module
UV	Ultraviolet
V/F	Velocity/Frequency
VCR	Videocassette Recorder
VIS	Visible
VRCS	Vernier Reaction Control System
WFOV	Wide Field of View
YAP	Yttrium-Aluminum Perovskite



Media Assistance

NASA Television Transmission

NASA Television is available through the GE2 satellite system which is located on Transponder 9C, at 85 degrees west longitude, frequency 3880.0 MHz, audio 6.8 MHz.

The schedule for television transmissions from the orbiter and for mission briefings will be available during the mission at Kennedy Space Center, Fla.; Marshall Space Flight Center, Huntsville, Ala.; Dryden Flight Research Center, Edwards, Calif.; Johnson Space Center, Houston, Texas; and NASA Headquarters, Washington, DC. The television schedule will be updated to reflect changes dictated by mission operations.

Status Reports

Status reports on countdown and mission progress, on-orbit activities and landing operations will be produced by the appropriate NASA news center.

Briefings

A mission press briefing schedule will be issued before launch. During the mission, status briefings by a flight director or mission operations representative and when appropriate, representatives from the payload team, will occur at least once each day. The updated NASA television schedule will indicate when mission briefings are planned.

Internet Information

Information is available through several sources on the Internet. The primary source for mission information is the NASA Human Space Flight Web, part of the World Wide Web. This site contains information on the crew and its mission and will be updated regularly with status reports, photos and video clips throughout the flight. The NASA Shuttle Web's address is:

<http://spaceflight.nasa.gov>

General information on NASA and its programs is available through the NASA Home Page and the NASA Public Affairs Home Page:

<http://www.nasa.gov>

or

<http://www.nasa.gov/newsinfo/index.html>



Shuttle Pre-Launch Status Reports

<http://www-pao.ksc.nasa.gov/kscpao/status/stsstat/current.htm>

Information on other current NASA activities is available through the Today@NASA page:

<http://www.nasa.gov/today/index.html>

The NASA TV schedule is available from the NTV Home Page:

<http://spaceflight.nasa.gov/realdata/nasatv/schedule.html>

Resources for educators can be found at the following address:

<http://education.nasa.gov>

Access by CompuServe

Users with CompuServe accounts can access NASA press releases by typing "GO NASA" (no quotes) and making a selection from the categories offered.



Media Contacts

Kyle Herring
NASA Headquarters
Washington
Space Shuttle/Space Station Policy
202-358-1874

Dolores Beasley
NASA Headquarters
Washington
Space Science Policy, Budget
dbeasley@hq.nasa.gov
202-358-1753

Eileen Hawley
Johnson Space Center
Houston
Astronauts/Mission Operations
Eileen.hawley1@jsc.nasa.gov
281-483-5111

George Diller
Kennedy Space Center
Kennedy Space Center, Fla.
Space Shuttle Launch Operations
George.Diller-1@ksc.nasa.gov
321-867-2468

Bruce Buckingham
Kennedy Space Center
Kennedy Space Center, Fla.
Launch Operations
Bruce.Buckingham-1@kmail.ksc.nasa.gov
321-867-2468

Steve Roy
Marshall Space Flight Center
Huntsville, Ala.
Microgravity Programs
steve.roy@msfc.nasa.gov
256-544-6535



Dave Drachlis
Marshall Space Flight Center
Huntsville, Ala.
Space Shuttle
Dave.Drachlis@msfc.nasa.gov
256-544-0034

Lori Rachul
Glenn Research Center
Cleveland, Ohio
Combustion, Fluid Physics and Acceleration Measurement Experiments
216-433-8806

Dewayne Washington
Public Affairs Specialist
NASA Goddard Space Flight Center
Greenbelt, MD 20771
FREESTAR Experiments
Ph: 301-286-0040
Fax: 301-286-1707

Kari Kelley Allen
Payloads Processing
The Boeing Company
kari.k.allen@boeing.com
281-226-4844

Dan Beck
Boeing Rocketdyne
Canoga Park, Calif.
Space Shuttle Main Engines
Daniel.c.beck@boeing.com
818-586-4572

Jessica Rye
United Space Alliance
Kennedy Space Center, Fla.
RyeJF@usano.ksc.nasa.gov
Shuttle Processing
321-861-4358



National Aeronautics and
Space Administration

STS-107 Shuttle Press Kit

Pete Pacey

SPACEHAB STS-107 Mission Manager

Work Phone: 713-558-5241

Pager: 281-434-9367

Console Number, Customer Support Room, Mission Control Center: 281-483-8975

Kimberly Campbell

STARS Payload Manager

SPACEHAB

Work phone: 713-558-5049

Cell phone: 832-276-4681



National Aeronautics and
Space Administration

STS-107: Media Contacts

Barbara Kakiris
Glenn Research Center
Cleveland, Ohio
Combustion, Fluid Physics and Acceleration Measurement Experiments
216-433-2513